



VIN

Mileage

LEGEND
■ OK (Checked and OK)
■ CHK (Will need future attention)
■ NOK (Not OK, replacement/repair needed)
 N/A (Not applicable)

1 PRELIMINARY		OK	CHK	NOK	N/A
1	Integrity full body cover and its removal	<input type="checkbox"/>	<input type="checkbox"/>	<input type="checkbox"/>	<input type="checkbox"/>
2	Logistic mode removal. At the end of the operation, disconnect the diagnostics tool and turn the vehicle key to OFF.	<input type="checkbox"/>	<input type="checkbox"/>	<input type="checkbox"/>	<input type="checkbox"/>
3	Car wash (if necessary) - NOTE: Hand washing with neutral product recommended	<input type="checkbox"/>	<input type="checkbox"/>	<input type="checkbox"/>	<input type="checkbox"/>
4	Car integrity for transport damage	<input type="checkbox"/>	<input type="checkbox"/>	<input type="checkbox"/>	<input type="checkbox"/>
5	Control data corresponding homologation car (chassis, labels, markings, etc.)	<input type="checkbox"/>	<input type="checkbox"/>	<input type="checkbox"/>	<input type="checkbox"/>
6	Car conformity vs order	<input type="checkbox"/>	<input type="checkbox"/>	<input type="checkbox"/>	<input type="checkbox"/>
7	Campaigns (recall/service) pending	<input type="checkbox"/>	<input type="checkbox"/>	<input type="checkbox"/>	<input type="checkbox"/>
8	MOT / Mandatory vehicle inspection (expiry date)	<input type="checkbox"/>	<input type="checkbox"/>	<input type="checkbox"/>	<input type="checkbox"/>
9	Vehicle tools kit & others on board equipment (license plate holder/bags/carpet/Fix&Go ...)	<input type="checkbox"/>	<input type="checkbox"/>	<input type="checkbox"/>	<input type="checkbox"/>
2 INTERIOR					
2.1 Driver's position					
1	Warning light(s) ON (ESC, Airbag, WRENCH,...)	<input type="checkbox"/>	<input type="checkbox"/>	<input type="checkbox"/>	<input type="checkbox"/>
2	Stored messages on-board computer	<input type="checkbox"/>	<input type="checkbox"/>	<input type="checkbox"/>	<input type="checkbox"/>
3	Instrument cluster operation (gauges, warning lamps, lighting and dimming)	<input type="checkbox"/>	<input type="checkbox"/>	<input type="checkbox"/>	<input type="checkbox"/>
4	Windshield wipers and washers: control stalk operation	<input type="checkbox"/>	<input type="checkbox"/>	<input type="checkbox"/>	<input type="checkbox"/>
5	Electric parking brake functionality	<input type="checkbox"/>	<input type="checkbox"/>	<input type="checkbox"/>	<input type="checkbox"/>
6	Horn functionality (all areas of pad)	<input type="checkbox"/>	<input type="checkbox"/>	<input type="checkbox"/>	<input type="checkbox"/>
7	Power windows and lock switch	<input type="checkbox"/>	<input type="checkbox"/>	<input type="checkbox"/>	<input type="checkbox"/>
8	Interior mirrors electrochromic dimming (test with flashlight)	<input type="checkbox"/>	<input type="checkbox"/>	<input type="checkbox"/>	<input type="checkbox"/>
9	Exterior mirrors electrochromic dimming (test with flashlight)	<input type="checkbox"/>	<input type="checkbox"/>	<input type="checkbox"/>	<input type="checkbox"/>
10	Driver's seat power movements and controls	<input type="checkbox"/>	<input type="checkbox"/>	<input type="checkbox"/>	<input type="checkbox"/>
11	Steering column movement (tilt, stroke)	<input type="checkbox"/>	<input type="checkbox"/>	<input type="checkbox"/>	<input type="checkbox"/>
12	Heated steering wheel (temperature adjustment functions, if present)	<input type="checkbox"/>	<input type="checkbox"/>	<input type="checkbox"/>	<input type="checkbox"/>
13	Side mirrors functionality (controls and heating)	<input type="checkbox"/>	<input type="checkbox"/>	<input type="checkbox"/>	<input type="checkbox"/>
14	HVAC controls/vents front and rear (functionality)	<input type="checkbox"/>	<input type="checkbox"/>	<input type="checkbox"/>	<input type="checkbox"/>
15	Glove box lid and light	<input type="checkbox"/>	<input type="checkbox"/>	<input type="checkbox"/>	<input type="checkbox"/>
16	Front ceiling courtesy light	<input type="checkbox"/>	<input type="checkbox"/>	<input type="checkbox"/>	<input type="checkbox"/>
17	Accessory power socket / cigar lighter	<input type="checkbox"/>	<input type="checkbox"/>	<input type="checkbox"/>	<input type="checkbox"/>
18	Sunroof and sunshade operation (if present)	<input type="checkbox"/>	<input type="checkbox"/>	<input type="checkbox"/>	<input type="checkbox"/>
19	Luggage compartment lid opening (with switch)	<input type="checkbox"/>	<input type="checkbox"/>	<input type="checkbox"/>	<input type="checkbox"/>
20	Radio/USB: date and time setting, audio quality, radio reception, display visibility and functionality	<input type="checkbox"/>	<input type="checkbox"/>	<input type="checkbox"/>	<input type="checkbox"/>
21	Multimedia controls: knobs and steering wheel commands	<input type="checkbox"/>	<input type="checkbox"/>	<input type="checkbox"/>	<input type="checkbox"/>
22	Test call with Bluetooth-connected mobile phone	<input type="checkbox"/>	<input type="checkbox"/>	<input type="checkbox"/>	<input type="checkbox"/>
23	Navigation system mapping updated	<input type="checkbox"/>	<input type="checkbox"/>	<input type="checkbox"/>	<input type="checkbox"/>
24	Wireless charger functionality (if present)	<input type="checkbox"/>	<input type="checkbox"/>	<input type="checkbox"/>	<input type="checkbox"/>
25	Owner's documentation	<input type="checkbox"/>	<input type="checkbox"/>	<input type="checkbox"/>	<input type="checkbox"/>
26	Check Carplay/Android Auto operation both via Cable and Wireless	<input type="checkbox"/>	<input type="checkbox"/>	<input type="checkbox"/>	<input type="checkbox"/>
27	Removal of all not necessary adhesives (e.g. on door panel under the armrest, on side glasses, on sunshades...)	<input type="checkbox"/>	<input type="checkbox"/>	<input type="checkbox"/>	<input type="checkbox"/>
28	Ambient light functionality	<input type="checkbox"/>	<input type="checkbox"/>	<input type="checkbox"/>	<input type="checkbox"/>
2.2 Left front					
1	Left front seat belt/height adjuster (sliding/return/insert)	<input type="checkbox"/>	<input type="checkbox"/>	<input type="checkbox"/>	<input type="checkbox"/>
2	Door button opening/closing functionality (with door lock ON/OFF). Check door opening from the outside with mechanical key and Smart key and from the internal with e-Latch and mechanical unlocking.	<input type="checkbox"/>	<input type="checkbox"/>	<input type="checkbox"/>	<input type="checkbox"/>
3	Door opening/closing noise or difficulties (with window up/down)	<input type="checkbox"/>	<input type="checkbox"/>	<input type="checkbox"/>	<input type="checkbox"/>
4	Left front seat heater (if present)	<input type="checkbox"/>	<input type="checkbox"/>	<input type="checkbox"/>	<input type="checkbox"/>
5	Left front seat ventilation (if present)	<input type="checkbox"/>	<input type="checkbox"/>	<input type="checkbox"/>	<input type="checkbox"/>
6	Door courtesy light	<input type="checkbox"/>	<input type="checkbox"/>	<input type="checkbox"/>	<input type="checkbox"/>

7	Left front power window	<input type="checkbox"/>	<input type="checkbox"/>	<input type="checkbox"/>	<input type="checkbox"/>
8	"Easy Entry" seat back tilt	<input type="checkbox"/>	<input type="checkbox"/>	<input type="checkbox"/>	<input type="checkbox"/>
9	Check the functioning of the vanity light on the sun visor	<input type="checkbox"/>	<input type="checkbox"/>	<input type="checkbox"/>	<input type="checkbox"/>
2.3 Left rear					
1	Left rear seat belt (sliding/return/insert)	<input type="checkbox"/>	<input type="checkbox"/>	<input type="checkbox"/>	<input type="checkbox"/>
2	Door button opening/closing functionality (with door lock ON/OFF). Check door opening from the outside with Smart key, and from the internal with e-Latch	<input type="checkbox"/>	<input type="checkbox"/>	<input type="checkbox"/>	<input type="checkbox"/>
3	Door opening/closing noise or difficulties (with window up/down)	<input type="checkbox"/>	<input type="checkbox"/>	<input type="checkbox"/>	<input type="checkbox"/>
4	Child lock	<input type="checkbox"/>	<input type="checkbox"/>	<input type="checkbox"/>	<input type="checkbox"/>
5	Left rear seat heater (if present)	<input type="checkbox"/>	<input type="checkbox"/>	<input type="checkbox"/>	<input type="checkbox"/>
6	Door courtesy light	<input type="checkbox"/>	<input type="checkbox"/>	<input type="checkbox"/>	<input type="checkbox"/>
7	Left rear power window	<input type="checkbox"/>	<input type="checkbox"/>	<input type="checkbox"/>	<input type="checkbox"/>
8	Left rear HVAC controls/vents	<input type="checkbox"/>	<input type="checkbox"/>	<input type="checkbox"/>	<input type="checkbox"/>
9	USB power sockets	<input type="checkbox"/>	<input type="checkbox"/>	<input type="checkbox"/>	<input type="checkbox"/>
10	Rear seat folding	<input type="checkbox"/>	<input type="checkbox"/>	<input type="checkbox"/>	<input type="checkbox"/>
2.4 Luggage compartment					
1	Luggage compartment opening and closing (with keyfobs, exterior and interior buttons and hands-free sensor)	<input type="checkbox"/>	<input type="checkbox"/>	<input type="checkbox"/>	<input type="checkbox"/>
2	Luggage compartment hinges, alignment and struts	<input type="checkbox"/>	<input type="checkbox"/>	<input type="checkbox"/>	<input type="checkbox"/>
3	Emergency equipment: reflective jacket, warning triangle, first aid kit (check expiry date)	<input type="checkbox"/>	<input type="checkbox"/>	<input type="checkbox"/>	<input type="checkbox"/>
4	Luggage compartment light	<input type="checkbox"/>	<input type="checkbox"/>	<input type="checkbox"/>	<input type="checkbox"/>
5	Tyre repair kit (presence, condition, expiry date)	<input type="checkbox"/>	<input type="checkbox"/>	<input type="checkbox"/>	<input type="checkbox"/>
6	Spare wheel (if present): condition, correct tyre pressure	<input type="checkbox"/>	<input type="checkbox"/>	<input type="checkbox"/>	<input type="checkbox"/>
7	Emergency tool kit (completeness)	<input type="checkbox"/>	<input type="checkbox"/>	<input type="checkbox"/>	<input type="checkbox"/>
8	Charging cables and accessories (presence, condition)	<input type="checkbox"/>	<input type="checkbox"/>	<input type="checkbox"/>	<input type="checkbox"/>
9	12V power socket	<input type="checkbox"/>	<input type="checkbox"/>	<input type="checkbox"/>	<input type="checkbox"/>
10	Charge Cable Emergency Unlock	<input type="checkbox"/>	<input type="checkbox"/>	<input type="checkbox"/>	<input type="checkbox"/>
2.5 Right rear					
1	Right rear seat belt (sliding/return/insert)	<input type="checkbox"/>	<input type="checkbox"/>	<input type="checkbox"/>	<input type="checkbox"/>
2	Door button opening/closing functionality (with door lock ON/OFF). Check door opening from the outside with Smart key, and from the internal with e-Latch	<input type="checkbox"/>	<input type="checkbox"/>	<input type="checkbox"/>	<input type="checkbox"/>
3	Door opening/closing noise or difficulties (with window up/down)	<input type="checkbox"/>	<input type="checkbox"/>	<input type="checkbox"/>	<input type="checkbox"/>
4	Child lock	<input type="checkbox"/>	<input type="checkbox"/>	<input type="checkbox"/>	<input type="checkbox"/>
5	Right rear seat heater (if present)	<input type="checkbox"/>	<input type="checkbox"/>	<input type="checkbox"/>	<input type="checkbox"/>
6	Door courtesy light	<input type="checkbox"/>	<input type="checkbox"/>	<input type="checkbox"/>	<input type="checkbox"/>
7	Right rear power window	<input type="checkbox"/>	<input type="checkbox"/>	<input type="checkbox"/>	<input type="checkbox"/>
8	Right rear HVAC controls/vents	<input type="checkbox"/>	<input type="checkbox"/>	<input type="checkbox"/>	<input type="checkbox"/>
9	USB socket	<input type="checkbox"/>	<input type="checkbox"/>	<input type="checkbox"/>	<input type="checkbox"/>
10	Rear seat folding	<input type="checkbox"/>	<input type="checkbox"/>	<input type="checkbox"/>	<input type="checkbox"/>
11	Dome lights	<input type="checkbox"/>	<input type="checkbox"/>	<input type="checkbox"/>	<input type="checkbox"/>
12	Central rear safety belt (sliding/return/insert)	<input type="checkbox"/>	<input type="checkbox"/>	<input type="checkbox"/>	<input type="checkbox"/>
2.6 Right front					
1	Right front seat belt/height adjuster (sliding/return/insert)	<input type="checkbox"/>	<input type="checkbox"/>	<input type="checkbox"/>	<input type="checkbox"/>
2	Door button opening/closing functionality (with door lock ON/OFF). Check door opening from the outside with Smart key, and from the internal with e-Latch	<input type="checkbox"/>	<input type="checkbox"/>	<input type="checkbox"/>	<input type="checkbox"/>
3	Door opening/closing noise or difficulties (with window up/down)	<input type="checkbox"/>	<input type="checkbox"/>	<input type="checkbox"/>	<input type="checkbox"/>
4	Power seat controls and movement	<input type="checkbox"/>	<input type="checkbox"/>	<input type="checkbox"/>	<input type="checkbox"/>
5	Right front seat heater (if present)	<input type="checkbox"/>	<input type="checkbox"/>	<input type="checkbox"/>	<input type="checkbox"/>
6	Right front seat ventilation (if present)	<input type="checkbox"/>	<input type="checkbox"/>	<input type="checkbox"/>	<input type="checkbox"/>
7	Door courtesy light	<input type="checkbox"/>	<input type="checkbox"/>	<input type="checkbox"/>	<input type="checkbox"/>
8	Right front sun visor	<input type="checkbox"/>	<input type="checkbox"/>	<input type="checkbox"/>	<input type="checkbox"/>
9	Check the functioning of the vanity light on the sun visor	<input type="checkbox"/>	<input type="checkbox"/>	<input type="checkbox"/>	<input type="checkbox"/>

3 EXTERIOR		
3.0 Exterior walkaround and security check		
1 All doors lock properly with keyfob	<input type="checkbox"/>	<input type="checkbox"/>
2 All doors unlock and open properly with keyfob	<input type="checkbox"/>	<input type="checkbox"/>
3 Check door opening/closure by proximity (keyless)	<input type="checkbox"/>	<input type="checkbox"/>
4 Anti theft alarm system (functionality)	<input type="checkbox"/>	<input type="checkbox"/>
5 Body, paintwork and glass damage	<input type="checkbox"/>	<input type="checkbox"/>
6 Panels alignment	<input type="checkbox"/>	<input type="checkbox"/>
7 Headlights: high and low beam, position/DRL, turn indicator and side marker lights	<input type="checkbox"/>	<input type="checkbox"/>
8 Side turn indicator lights	<input type="checkbox"/>	<input type="checkbox"/>
9 Taillights: position, brake (side and central), reverse, turn indicator, and fog lights	<input type="checkbox"/>	<input type="checkbox"/>
10 Side vents lighting	<input type="checkbox"/>	<input type="checkbox"/>
3.1 Front exterior		
1 Front headlight lens condition	<input type="checkbox"/>	<input type="checkbox"/>
2 Front bumper, grille and trident emblem (fixing, alignment, damages)	<input type="checkbox"/>	<input type="checkbox"/>
3 Windscreen glass	<input type="checkbox"/>	<input type="checkbox"/>
4 Windscreen wiper blades	<input type="checkbox"/>	<input type="checkbox"/>
5 Towbar: check presence, installation, safety key and front bumper cover	<input type="checkbox"/>	<input type="checkbox"/>
3.2 Left front exterior		
1 Door lock cylinder functionality	<input type="checkbox"/>	<input type="checkbox"/>
2 Keyless entry functionality: door unlock/lock (see user manual)	<input type="checkbox"/>	<input type="checkbox"/>
3 Left front side mirror housing and glass	<input type="checkbox"/>	<input type="checkbox"/>
4 Left front door hinge and alignment	<input type="checkbox"/>	<input type="checkbox"/>
5 Left front door seals	<input type="checkbox"/>	<input type="checkbox"/>
3.3 Left rear exterior		
1 Left rear door hinge and alignment	<input type="checkbox"/>	<input type="checkbox"/>
2 Left rear door seals	<input type="checkbox"/>	<input type="checkbox"/>
3.4 Rear exterior		
1 Rear window wiper blade	<input type="checkbox"/>	<input type="checkbox"/>
2 Rear bumper fascia (fixing, alignment, damages)	<input type="checkbox"/>	<input type="checkbox"/>
3 Towing hook: presence, mounting, security key, bumper hatch cover	<input type="checkbox"/>	<input type="checkbox"/>
4 Charge door correctly locking and unlocking	<input type="checkbox"/>	<input type="checkbox"/>
3.5 Right rear exterior		
1 Right rear door hinge and alignment	<input type="checkbox"/>	<input type="checkbox"/>
2 Right rear door seals	<input type="checkbox"/>	<input type="checkbox"/>
3.6 Right front exterior		
1 Keyless entry functionality: door unlock/lock (see user manual)	<input type="checkbox"/>	<input type="checkbox"/>
2 Right front side mirror housing and glass	<input type="checkbox"/>	<input type="checkbox"/>
3 Right front door hinge and alignment	<input type="checkbox"/>	<input type="checkbox"/>
4 Right front door seals	<input type="checkbox"/>	<input type="checkbox"/>
3.7 Top exterior		
1 Sunroof glass and seals (test for leaks) (if present)	<input type="checkbox"/>	<input type="checkbox"/>
3.8 Wheels and tyres		
1 Tyres: correct size and specification	<input type="checkbox"/>	<input type="checkbox"/>
2 Rims	<input type="checkbox"/>	<input type="checkbox"/>
3 Pressure (measure with gauge)	<input type="checkbox"/>	<input type="checkbox"/>
4 Bolts tightening (with dynamometric wrench)	<input type="checkbox"/>	<input type="checkbox"/>
4 ENGINE COMPARTMENT		
1 Engine cover/insulation (integrity, fixing)	<input type="checkbox"/>	<input type="checkbox"/>
2 Lid latch release mechanism and secondary or safety catch	<input type="checkbox"/>	<input type="checkbox"/>
3 Windscreen washer fluid level and reservoir cap	<input type="checkbox"/>	<input type="checkbox"/>
4 Engine coolant circuit(s): fluid level, reservoir and cap integrity	<input type="checkbox"/>	<input type="checkbox"/>
5 Brake fluid level, reservoir and cap check	<input type="checkbox"/>	<input type="checkbox"/>
6 12V battery: secure attachment, correct type, no visible damage	<input type="checkbox"/>	<input type="checkbox"/>

7 General inspection of all electrical components and visible HV components (no leaks and damage)	<input type="checkbox"/>	<input type="checkbox"/>
5 UNDER THE VEHICLE		
5.1 Under body		
1 Steering arms, rack and boots: integrity and leak check	<input type="checkbox"/>	<input type="checkbox"/>
2 Bottom of front and rear bumpers (visual damage)	<input type="checkbox"/>	<input type="checkbox"/>
3 Side sills (fixing, condition)	<input type="checkbox"/>	<input type="checkbox"/>
4 Visual inspection of all exposed electrical components and connections	<input type="checkbox"/>	<input type="checkbox"/>
5 Visible leaks	<input type="checkbox"/>	<input type="checkbox"/>
5.2 Transmission/Transaxle/Differential		
1 Visible leaks	<input type="checkbox"/>	<input type="checkbox"/>
5.3 Brakes		
1 Brake calipers, hoses, lines and fittings: inspect for cracks and leaks	<input type="checkbox"/>	<input type="checkbox"/>
6 OVERALL FUNCTIONAL ROAD TEST		
1 AWD disconnect function (if present)	<input type="checkbox"/>	<input type="checkbox"/>
2 Drive modes [MAX RANGE-GT-SPORT-OFF ROAD]	<input type="checkbox"/>	<input type="checkbox"/>
3 eCoasting (Level Paddles: D-- / D- / D / D+) and eBraking system functionality	<input type="checkbox"/>	<input type="checkbox"/>
6.1 Braking		
1 Parking brake (proper operation)	<input type="checkbox"/>	<input type="checkbox"/>
6.2 Overall driveability and functionality		
1 Steering behaviour (tracking, pulling, play in the steering system)	<input type="checkbox"/>	<input type="checkbox"/>
2 Steering wheel (return, central position alignment, free play, symmetry in turning circle)	<input type="checkbox"/>	<input type="checkbox"/>
3 Overall vehicle ride quality (noise, vibration)	<input type="checkbox"/>	<input type="checkbox"/>
4 Activation of Voice Assistante through the head unit: from the menu "Settings" of "Vehicle" page, check that the function "Voice" is checked.	<input type="checkbox"/>	<input type="checkbox"/>
5 AVAS and BEV sound system functionality	<input type="checkbox"/>	<input type="checkbox"/>
6 SAT/NAVI functionality	<input type="checkbox"/>	<input type="checkbox"/>
7 HVAC operating performance (selecting COLD - HOT)	<input type="checkbox"/>	<input type="checkbox"/>
8 Rear/surround view system (test and lens cleaning)	<input type="checkbox"/>	<input type="checkbox"/>
9 Parking sensors operation (front and rear, both sides)	<input type="checkbox"/>	<input type="checkbox"/>
10 Rear view camera/360° view camera (check functionality)	<input type="checkbox"/>	<input type="checkbox"/>
11 Air suspension: all levels available, from Park to Off road 2 (except Aero 2, not available in static)	<input type="checkbox"/>	<input type="checkbox"/>
6.3 After road test		
1 Visible leaks	<input type="checkbox"/>	<input type="checkbox"/>
2 Check warning lamps and stored messages	<input type="checkbox"/>	<input type="checkbox"/>
3 Check for error codes using MD tester	<input type="checkbox"/>	<input type="checkbox"/>
7 OTHER CHECKS		
1 Trunk for factory supplied items (floor mats, extra key, hub caps, plate brackets)	<input type="checkbox"/>	<input type="checkbox"/>
2 TBM connection unlocked - refer to Workshop procedure n. 08.71.224 35 (Connection check)	<input type="checkbox"/>	<input type="checkbox"/>
3 Maserati Connect customer enrolled - ref. Network Development/Operating Guidelines/Enrollment Process on ModisCS+ and Operating Requirements on Dealer Intelligence	<input type="checkbox"/>	<input type="checkbox"/>
4 (Not for USA & CANADA) If delivery to the customer is not expected within 2 days, reset the Logistic Mode	<input type="checkbox"/>	<input type="checkbox"/>
5 Check of correct fitting of front and rear number plate holder	<input type="checkbox"/>	<input type="checkbox"/>
6 Check of HV battery state of charge and top-up, if necessary	<input type="checkbox"/>	<input type="checkbox"/>

8. FAULT LOCATION

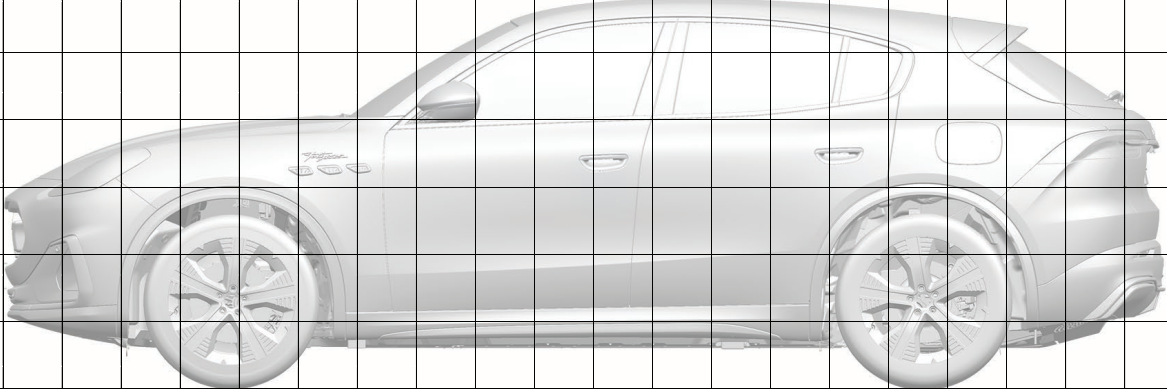
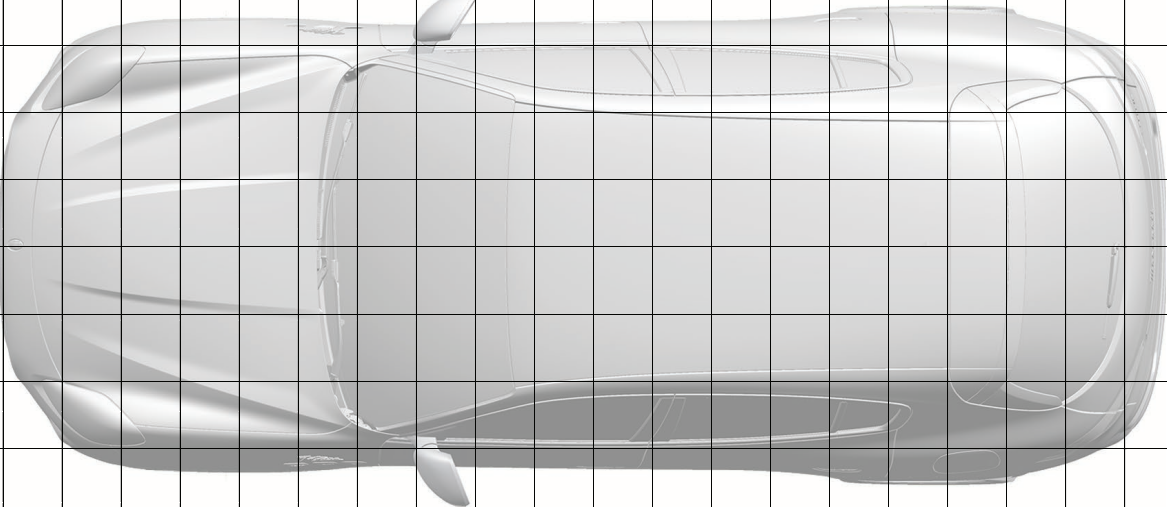
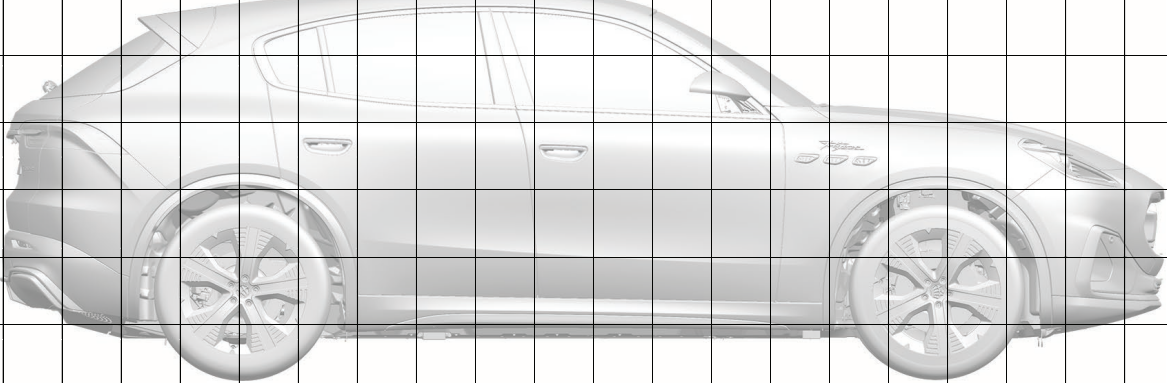
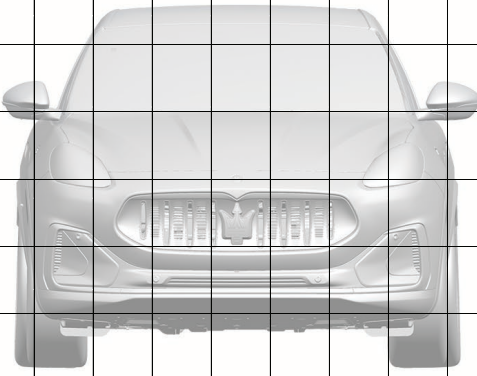
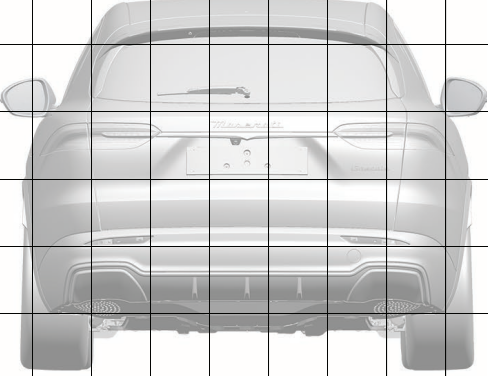
	1	2	3	4	5	6	7	8	9	10	11	12	13	14	15	16	17	18	19	20	21	22	23
A																							
B																							
C																							
D																							
E																							
F																							
G																							
H																							
I																							
J																							
K																							
L																							
M																							
N																							
O																							
P																							
Q																							
R																							
S																							
T																							
U																							
V																							
W																							
X																							
Y																							
Z																							

Insert coordinates, suspected component (if identified)

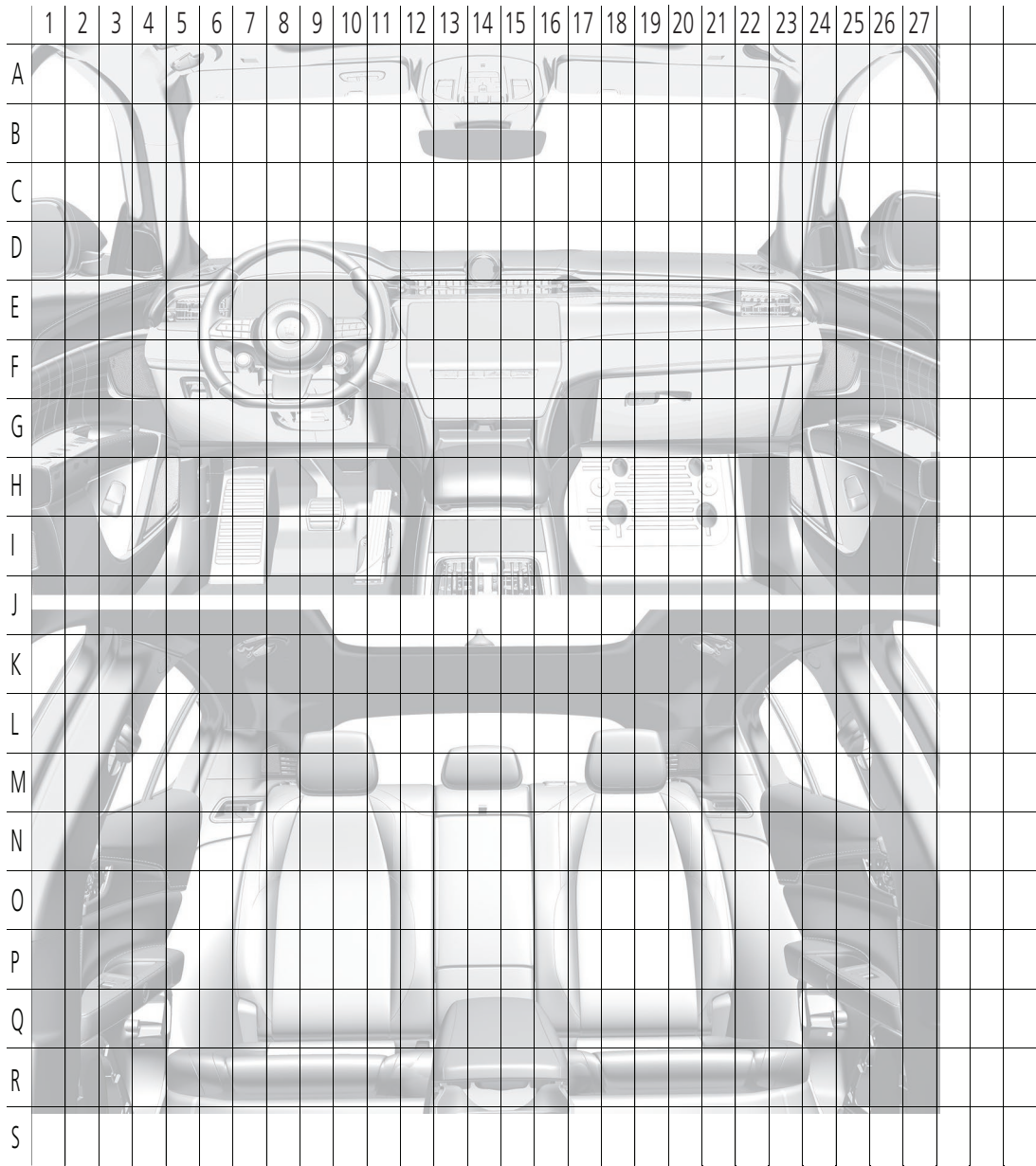

Insert coordinates, suspected component (if identified)

Extra/Notes

Section Item

<input type="checkbox"/>	<input type="checkbox"/>	/	<input type="checkbox"/>	<input type="checkbox"/>	_____
<input type="checkbox"/>	<input type="checkbox"/>	/	<input type="checkbox"/>	<input type="checkbox"/>	_____
<input type="checkbox"/>	<input type="checkbox"/>	/	<input type="checkbox"/>	<input type="checkbox"/>	_____
<input type="checkbox"/>	<input type="checkbox"/>	/	<input type="checkbox"/>	<input type="checkbox"/>	_____
<input type="checkbox"/>	<input type="checkbox"/>	/	<input type="checkbox"/>	<input type="checkbox"/>	_____
<input type="checkbox"/>	<input type="checkbox"/>	/	<input type="checkbox"/>	<input type="checkbox"/>	_____

Dealership stamp

Inspection performed by
(Name/Surname)

Inspection date
(MM/DD/YYYY)

Signature