



保养条目 +

用户指南

2024 EDITION

索引

简介	3	填写维修信息	71	阻止错误 WW0279	138
搜索保养条目	5	输入 BOL 请求	85	阻止错误 WW0267	140
查看保养条目数据	9	进入“BOL+”工作表	86	已阻止索赔的解锁请求	141
检查车辆数据	14	填写“BOL+”工作表	87	已阻止保养条目的解锁请求	150
车辆信息	15	“诊断”工作表查询	88	管理保养条目状态	156
活动	18	BOL 交互	89	保养条目状态	157
保修	20	BOL 参考	90	“已打开”状态	160
BOL	21	提交保修索赔并关闭保养条目	91	“删除”状态	161
车辆配置更新	22	进入“保修”工作表	92	维修暂停状态	163
保养条目	23	填写保修索赔申请	93	维修暂停状态 - 等待备件	164
客户数据	24	索赔处于临时状态	99	维修暂停状态 - 等待技术支持	168
档案列表	25	进入“关闭”工作表	100	维修暂停状态 - 转租进行中	169
保养	26	输入关闭数据	101	维修暂停状态 - 等待授权	170
Maserati 互联	27	“首次维修即解决问题 (FRFT)”选择	102	维修暂停状态 - 等待车辆交付	171
打开保养条目	28	更新车辆参数	103	自动发送消息	172
进入“车辆条目”工作表	29	保养条目关闭	106	保养条目连接功能	173
输入客户和车辆数据	30	发送索赔	107	激活流程	174
输入主要访问信息	31	索赔状态	110	“返回新订阅”流程	180
所有权变更	32	管理保养条目阻止警告	111	更换车辆管理	184
提供的移动服务	46	CRM 案例标记 (CRM)	114	代步车: 分配	185
已登记保养条目	52	通用标记 (GEN)	115	代步车: 额外天数请求	193
输入作业线	53	出口至/进口自国外市场标记 (EFM)	116	代步车: 关闭分配	197
进入“维修”工作表	54	已撞毁标记 (INC)	118	代步车: 删除分配	199
第一次打卡日期	55	被盗标记 (RUB)	120	租赁车辆: 标准天数分配	200
异常作业线	56	已报废标记 (ROT)	121	租赁车辆: 额外天数请求	202
付费保养作业线	64	已修改里程数标记 (KMM)	122	租赁车辆: 更新分配	206
活动作业线	65	已改装标记 (MOD)	124	租赁车辆: 删除分配	207
保养计划作业线	67	发动机控制单元已改装 (CMM)	126	租赁车辆: 确认分配	208
额外保养作业线	69	阻止错误 WW0010	135	租赁车辆: 关闭分配	211
付费维修作业线	70	阻止错误 WW0069	136	最佳实践	212



简介

简介

保养条目+ 是一个可通过 ModisCS+ 访问的平台，用于管理车辆使用寿命，用作经销商和工厂之间的接口。

保养条目+ 执行以下任务：

- 存储车辆使用寿命（保养和维修历史记录、保修历史记录、参与过的活动等）
- 跟踪执行特定维修服务（保养与召回活动、更新等）。
- 通过 Blue On Line + 管理技术支持请求和异常报告
- 提交保修索赔
- 包含车辆特定数据（有效保修、参数、装备、颜色、装配编号、发动机编号等）

“保养条目”必须在车辆进入车间后无条件打开，在车辆返回给客户时关闭。通常由服务顾问完成。

对车辆执行的所有保养和维修作业都必须输入到保养条目+ 中。

如此，“保养条目”实质上成为由厂家进行监控的“维修单”。



搜索保养条目

搜索保养条目

在 ModisCS+ 主页上，单击“售后”(Aftersales)/“保养条目”(Service Entry) 菜单。



搜索保养条目

然后单击“保养条目管理”(Service Entry Management) 菜单。



搜索保养条目

您可以通过以下方式搜索保养条目：

- 底盘号
- 保养条目编号
- 经销商
- 维修单
- 保养条目状态
- BOL 编号
- 维修单打开日期
- 打开的客户案例（全部\是\否）

The screenshot displays the ModisCS+ interface for Service Entry Management. The top navigation bar includes the logo, the user's location (ROSSOCORSA - MILANO), the page title (SERVICE ENTRY MANAGEMENT), and user information (SAT Training (Aftersales) Logout). A left sidebar menu lists various service categories, with 'SERVICE ENTRY MANAGEMENT' highlighted in yellow. The main content area features a 'Search for' panel with the following filters and counts:

Filter	Count
Repair in Progress	56
Repair on Hold	24
Closed with claims to be completed	520

Additional search criteria include:

- Chassis no. (text input)
- Service Entry # (text input)
- Dealer (dropdown menu)
- Service Entry Status (dropdown menu, set to 'All')
- BOL # (text input)
- Repair Order # (text input)
- Open Customer Case (dropdown menu, set to 'All')
- Repair order opening date (date range input: From [] To [])

A 'Search' button is located at the bottom of the search panel.

您还可以查看“维修进行中”、“维修暂停”或“已关闭但索赔已完成”的保养条目。



查看保养条目数据

查看保养条目数据

找到要查找的保养条目后，单击左侧按钮查看其详细信息。

ModisCS+ ROSSOCORSA - MILANO SERVICE ENTRY MANAGEMENT SAT Training (Aftersales) Logout

Search for

Repair in Progress 56 Repair on Hold 24 Closed with claims to be completed 520

Chassis no. Service Entry # IT0098584 Dealer

Service Entry Status All BOL # Open Customer Case All

Repair order opening date From To

Search

	Service Entry #	Repair Order#	Dealer	Chassis no.	Date	Mileage	In Date	Out Date	Mileage	Service Entry Status
	IT0098584	846163	52222 ROSSOCORSA S.R.L.	397895	01.08.2023	33000 K	01.08.2023		33001 K	Closed

1 / 1

<=> <<=> <=> >>=> >=> Excel

查看保养条目数据

在第 1 个工作表“1.车辆条目” (1.Vehicle Entry) 中，您可以在顶部找到与车辆车间访问有关的所有详细信息，在底部找到与车辆、客户、活动和先前干预措施有关的信息。在该页，单击专用按钮，还可以打印包含主要车辆/访问数据的车辆报告，并访问该车的专用“通函” (Bulletins) 和“在线知识” (Knowledge on Line) 部分。

1. Vehicle Entry2. Repair3. Close

Vehicle Entry

Service Entry #	Opening date	Last Update	Days down	Vehicle Downtime	Previous Repair#
IT0098595	16.11.2023	16.11.2023 - WBTESTHQ2	2	1	2

Service Entry Status Status Changes

O - Open Repair in Progress

Dealer
052222 - ROSSOCORSA S.R.L.

Chassis no.	Plate #	Customer Name	Actual Owner
327800	FV358HT	LEVANTE S	客户名字 Yes <input type="radio"/> No <input checked="" type="radio"/>

Repair Order#	Repair order opening date	Mileage In	Vehicle towed in due to technical issues	Loaner Car
54321	16.11.2023	Km <input checked="" type="radio"/> M <input type="radio"/> 25200	Yes <input type="radio"/> No <input checked="" type="radio"/>	Yes <input type="radio"/> No <input checked="" type="radio"/>

Mobility services provided
Yes No 1 selected

Fleet Vehicle
Yes No

Service Note
Leaking water radiator. Rear taillight damaged

Back to listCheckSaveVehicle ReportBulletinsKnowledge on Line

Warning

WW0747:RegularWarranty to be started or RepairDate less than Reg.Wty Start Date

WW0370:No Open Campaigns for this vehicle

If current owner flag has been selected by mistake, open Ticket.

One or more Privacy consents are missing. Please present our Policy to the customer and request consents.

查看保养条目数据

在该工作表顶部末尾，您可以找到有关输入数据的任何警告。

阻止警告以灰色突出显示，信息性警告以粉红色突出显示。

1. Vehicle Entry2. Repair3. Close

Vehicle Entry

Service Entry #	Opening date	Last Update	Days down	Vehicle Downtime	Previous Repair#
IT0098584	01.08.2023	01.08.2023 - ITRSCA07	1	408	4

Status
Status Changes
C - Closed

Dealer
052222 - ROSSOCORSA S.R.L.

Chassis no.	Plate #	Customer Name	Actual Owner
397895		LEVANTE HYBRID 客户名字	Yes <input type="radio"/> No <input type="radio"/>

Repair Order#	Repair order opening date	Mileage In	Vehicle towed in due to technical issues	Loaner Car
846163	01.08.2023	Km <input checked="" type="radio"/> M <input type="radio"/> 33000	Yes <input type="radio"/> No <input checked="" type="radio"/>	Yes <input type="radio"/> No <input checked="" type="radio"/>

Mobility services provided
Yes No Not Offered

Fleet Vehicle
Yes No

Service Note

Back to list Save Vehicle Report Bulletins Knowledge on Line

WW0013:Current mileage less than the mileage on previous repair

WW0230:Mileage has to greater than previous claims 2

Warning

WW0656:The VIN has been previously repaired on date 01.08.2023

WW0370:No Open Campaigns for this vehicle

One or more Privacy consents are missing. Please present our Policy to the customer and request consents.

There is no Maserati Connect active subscription for this vehicle. Customer is eligible for the registration process.

有关保养条目警告的更多信息，请参阅本手册的“管理保养条目阻止警告”部分。

查看保养条目数据

单击“状态更改”(Status Changes)按钮，可以查看多个保养条目的状态更改。

Status	Reason	Operator	Operation Date	Status duration
Open		USTNKG09	09/14/2023	1
Repair on Hold	Waiting for Tech. support	US05513	09/15/2023	0
Open		SE_BOLWL	09/15/2023	7
Repair on Hold	Waiting for Tech. support	US05513	09/22/2023	0
Open		SE_BOLWL	09/22/2023	24
Repair on Hold	Waiting parts	USTNKG09	10/16/2023	3
Open		*INT.JOB*	10/19/2023	26
Closed		USTNKG09	11/14/2023	-

Vehicle Entry form fields:

- Service Entry #: IT0098584
- Status: Status Changes (highlighted)
- C - Closed
- Dealer: 052222 - ROSSOCORSA S.R.L.
- Chassis no.: 397895
- Repair Order#: 846183
- Mobility services provided: Yes No
- Fleet Vehicle: Yes No
- Service Note: [Empty]

Buttons: Back to list, Save

Warnings:

- WW0013: Current mileage less than the mileage on previous repair
- WW0230: Mileage has to greater than previous claims 2
- Warning
- WW0656: The VIN has been previously repaired on date 01.08.2023
- WW0370: No Open Campaigns for this vehicle
- One or more Privacy consents are missing. Please present our Policy to the customer and request consents.
- There is no Maserati Connect active subscription for this vehicle. Customer is eligible for the registration process.



有关保养条目状态的正确管理，请参阅通函：

- MAS003323 “保养条目管理：最佳实践”
- MAS003354 “保养条目管理：正确使用‘维修暂停’状态”
- MAS003513 “保养条目管理：新的‘暂停 - 等待技术支持’状态的自动切换和车辆故障天数警报”



检查车辆数据

检查车辆数据

车辆信息

在工作表“1.车辆条目”(1.Vehicle Entry)的底部，您可以找到“车辆信息”(Vehicle Information)选项卡和相关工作表，其中包括以下数据：

- 组件
- V.I.N.
- 车型项目代码
- 发动机和齿轮箱编号
- 可选部件
- 保修开始/结束日期
- 销售国家/地区
- 客户计划（如已激活）
（延长保修计划、认证二手车保修计划，等）
- 任何注释（例如，车辆上激活的阻止标记）

The screenshot displays the ModisCS+ interface for 'SERVICE ENTRY MANAGEMENT' at 'ROSSOCORSA - MILANO'. The 'Vehicle Entry' tab is active, and the 'Vehicle Information' sub-tab is selected. The main content area is divided into several sections:

- Vehicle Information:** A table with fields: Chassis no. (397895), Vehicle (881170000), V.I.N. (ZN6AU61B00X397895), Assembly # (8102227), Model Year (2022), PDI Status (Dealer Acceptance), Finishing date (08.03.2022), Arrival Date (10.03.2022).
- Engine and Gearbox:** A table with fields: Type, Number, Ing. key (M0874), Immo Code (9699), Sales Country (Italy), Wheel Size (N/A), Tyre DOT 1-4 (0XT53V1175021, 0XT53V1175021, 0XTB2V1162021, 0XTB2V1162021), Radio Srt# (T00260112901840), Customer Name (ROSSOCORSA S.R.L.), Invoice Ref. (2649), Invoice Ref. (10.03.2022).
- Warranty:** A table with columns: Services Type, Start Date, End Date. One entry: Warranty (28.03.2022, 28.03.2025).
- Finish:** A table with fields: External Color (94084202, GRIGIO), Internal Color (94084349, TAN/TAN), Carpets (94084336, TAN/BLACK/TAN).
- Option List:** A table with columns: Code, Colour Code. Includes options like DASH UPPER DASH & CLUSTER BROW, KDFIT DEFAULT COMPLEMENTARY OPT.LE, KFIX SPARE WHEEL/FIX & GO SELECTION, etc.
- Vehicle Configuration Update:** A table with columns: Replacement date, Part Number, Number. Includes entries like ROO2 HEADLINER & PILLARS, STWH STEERING WHEEL & SHIFTER.

检查车辆数据

车辆信息

在“车辆信息” (Vehicle Information) 工作表中，您还可以找到“打印” (Print) 和“更改请求保修/重新打印标签” (Change Request Warranty / Reprint Labels) 按钮。

单击“打印” (Print)，您可以打印“车辆信息” (Vehicle Information) 工作表中包含的信息。

The screenshot shows the ModisCS+ interface for SERVICE ENTRY MANAGEMENT. The left sidebar lists various modules, with 'SERVICE ENTRY MANAGEMENT' highlighted. The main area displays the 'Vehicle Entry' section, with 'Vehicle Information' selected. The interface is divided into three tabs: 1. Vehicle Entry, 2. Repair, and 3. Close. The 'Vehicle Information' tab is active, showing a table of vehicle details. The 'Warranty' section is also visible, showing a table of warranty services. At the bottom, the 'Print' and 'Change Request Warranty/ Reprint Labels' buttons are highlighted.

Vehicle Information		
Chassis no.	397895	
Vehicle	801170000	L4 MHEV 330HP EUROPEGT
V.I.N.	ZN6AU61B00X397895	
Assembly #	8102227	
Model Year	2022	
PDI Status	Dealer Acceptance	
Finishing date	09.03.2022	
Arrival Date	10.03.2022	
Type	Number	
Engine	1845310	
Gearbox	1486344	
Eng. key	M0874	
Immo Code	9699	
Sales Country	Italy	
Wheel Size	N/A	
Tyre DOT 1	0XT53V1175021	
Tyre DOT 2	0XT53V1175021	
Tyre DOT 3	0XTB2V1182021	
Tyre DOT 4	0XTB2V1182021	
Radio S/n#	T00260112901840	
Customer Name	82222	ROSSOCORSA S.R.L.
Invoice Ref.	2649	
Invoice Ref.	10.03.2022	

Services Type	Start Date	End Date
Warranty	28.03.2022	28.03.2025

Finish		
External Color	94084202	GRIGIO
Internal Color	94084349	TAN/TAN
Carpets	94084336	TAN/BLACK/TAN

Code	Colour Code		
DASH	UPPER DASH & CLUSTER BROW	094084336	TAN/BLACK/TAN
KDFT	DEFAULT COMPLEMENTARY OPT.LE		
KFIX	SPARE WHEEL/FIX & GO SELECTION		
KNAV	CTP SELECTION		
QMFS	Black Gloss Front Grille		
QRB4	MTC Plus With Navi & DAB		
Q5JB	Traffic Sign Recognition (TSR)		
QXZ2	Kick Sensor		
Q1T4	Driver Assistance Pack Plus		
Q137	Electric-Adjustable Steering		
Q2D5	Eco Level Euro 6d Final		
Q2XY	Active Driving Assist		
Q2Y5	Sport Package		
Q204	Four-Zone Climate Control		
Q210	Metallic Paint		
Q228	Soft-Close Doors		
Q3LN	Welcome Pack		
Q3QL	Light Blue Brake Calipers		
Q3XY	Connectivity Pack		
Q389	Licence Plate Predisposition		
Q390	Panorama Sunroof		
Q4AV	20" Staggered Elfesto		
Q4HV	Extended Leather Upholstery		
Q4MN	Open Pore Radica Wood Trim		
Q4NC	Pirelli Tyres		
Q407	Shift Padd. On Steering Column		
Q44B	Dual Cast Braking System Perf.		
Q490	Fix&Go Tyre Kit (I-POL-GB-TUR)		
Q508	Front And Rear Parking Sensors		
Q8BN	Sport St.Wheel Black Leather		
Q95H	Compulsory Pack		
RO02	HEADLINER & PILLARS	094084295	BLACK
STWH	STEERING WHEEL & SHIFTER	094084351	BLACK/BLACK

Vehicle Configuration Update		
Replacement date	Part Number	Number
Records not found		

检查车辆数据

车辆信息

单击“更改请求保修/重新打印标签”(Change Request Warranty / Reprint Labels) 按钮，您可以打开一个窗口，请求更改保修开始日期，或在保修开始日期起 48 个月后再重新打印车辆的保修标签（在 48 个月内，您可以打印标签而无需输入请求）。

The screenshot displays the ModisCS+ interface for Service Entry Management. The top navigation bar includes the ModisCS+ logo, the user's location (ROSSOCORSA - MILANO), the current page title (SERVICE ENTRY MANAGEMENT), and user options (SAT Training (Aftersales) and Logout). A left-hand sidebar contains a menu of various service and warranty-related functions, with 'SERVICE ENTRY MANAGEMENT' highlighted at the bottom.

The main content area features a search window with the following details:

- Search for:** Chassis no. 397895
- Table Headers:** Id, Type, Dealer's Note, Factory's Note, Status, Send Date, Approval Date
- Table Content:** Records not found (1 / 1)
- Actions:** Delete Request, Send Request, Save notes, Close, Excel

Below the search results, there are two expandable sections:

- Change requests warranty start date:** Includes a 'Change Warranty Start Date' button and a note: "From this menu you can manage only the change requests warranty. To change clients data (Name, Surname, Address) and reprint the updated labels, you have to perform the change of ownership through Service Entry."
- Print labels - Reprint Labels Requests:** Includes buttons for 'Reprint request Labels', 'Warranty Cards', and 'Warranty + Assistance Cards', along with a note: "To print the labels after 48 months from the warranty start date, you have to open a reprint labels request"

检查车辆数据

活动

单击“活动”(Campaign)按钮，您可以找到有关车辆已执行或待执行活动的信息。如果活动中报告了与经销商和保修索赔编号有关的数据，则表示活动已经执行。

以蓝色突出显示的活动为阻止活动。

如果不为其提交保修索赔，则无法发送任何其他索赔。

相反，可以关闭保养条目。







单击相关扳手查阅活动技术通函。

1. Vehicle Entry2. Repair3. Close

Vehicle Entry

Vehicle Information Campaign Warranty BOL Change of Ownership Vehicle Configuration Update Service Entry Customer Data

Dossier list Rental Car Maintenance

Campaign #	Cost Code	Component Code	Description	Chassis no.	Warranty Claim #	Warranty Date	Dealer		Link to Doc
275	23	57020021	ENGINE COOLANT	77538	2	22/02/17	52222	ROSSOCORSA S.R.L.	
288	23	57190001	PROGRAMMED IGNITION	77538	7	19/07/16	52222	ROSSOCORSA S.R.L.	
301	24	57520109	ACCELERATOR PEDAL CO	77538	8	19/07/16	52222	ROSSOCORSA S.R.L.	
303	24	57620142	REAR CONVERGENCY ADJ	77538	9	19/07/16	52222	ROSSOCORSA S.R.L.	
307	24	57931007	RH FRONT DOOR LOCK	77538	1	22/02/17	52222	ROSSOCORSA S.R.L.	
339	24	57143109	UNDERFLOOR FUEL PIP	77538	0		0		
342	24	57941090	PILOT SIDE FRONT SEA	77538	0		0		

Attention: the background colored indicates the mandatory campaigns

Attention: the background colored indicates the FOTA campaigns

2 / 2

◀ ◁ ☹ ▷ ▶Excel

检查车辆数据

活动

1. Vehicle Entry2. Repair3. Close

Vehicle Entry

Vehicle InformationCampaignWarrantyBOLChange of OwnershipVehicle Configuration UpdateService EntryCustomer Data

Dossier listRental CarMaintenance

Campaign #	Cost Code	Component Code	Description	Chassis no.	Warranty Claim #	Warranty Date	Dealer		Link to Doc
275	23	57020021	ENGINE COOLANT	77538	2	22/02/17	52222	ROSSOCORSA S.R.L.	
288	23	57190001	PROGRAMMED IGNITION	77538	7	19/07/16	52222	ROSSOCORSA S.R.L.	
301	24	57520109	ACCELERATOR PEDAL CO	77538	8	19/07/16	52222	ROSSOCORSA S.R.L.	
303	24	57620142	REAR CONVERGENCY ADJ	77538	9	19/07/16	52222	ROSSOCORSA S.R.L.	
307	24	57931007	RH FRONT DOOR LOCK	77538	1	22/02/17	52222	ROSSOCORSA S.R.L.	
339	24	57143109	UNDERFLOOR FUEL PIPI	77538	0	0			
342	24	57941090	PILOT SIDE FRONT SEA	77538	0	0			

Attention: the background colored indicates the mandatory campaigns

Attention: the background colored indicates the FOTA campaigns

2 / 2

⏪ ⏩🔄⏴ ⏵Excel



在向客户交付车辆之前，不要忘记检查待处理的活动！

检查车辆数据

保修

在“保修”(Warranty)工作表中，您可以看到为车辆提交的所有索赔，但交付前索赔（成本代码 12）除外，这些索赔在 ModisCS+ 的“保修管理”(Warranty Management) 菜单中可见。

1. Vehicle Entry		2. Repair		3. Close							
Vehicle Entry											
Vehicle Information		Campaign	Warranty	BOL	Change of Ownership		Vehicle Configuration Update		Service Entry	Customer Data	
Dossier list		Rental Car		Maintenance							
Warranty Status	Cost Code	Branch	Dealer	Repair Order#	Warranty Claim #	Service Entry #	Date out	Defective Component	Description	Defect	Mileage Out
F	16	ROSSOCORSA S.R.L.	ROSSOCORSA S.R.L.	2014244	1	IT0000658	17.03.2014	57430102	COMPLETE HANDBRAKE ELECTRONIC	DEFECTIVE ADJUSTEMENT OR SETTI	Km 9286
F	16	ROSSOCORSA S.R.L.	ROSSOCORSA S.R.L.	2862014	1	IT0000887	08.04.2014	57400001	BRAKE SERVO	DIFFICULT OR FAULTY DRIVE	Km 9390
F	16	ROSSOCORSA S.R.L.	ROSSOCORSA S.R.L.	2014400	1	IT0001356	16.05.2014	57144122	PIPE TO INTAKE MANIFOLD	NOISE, KNOCK	Km 13522
F	23	ROSSOCORSA S.R.L.	ROSSOCORSA S.R.L.	2014435	1	IT0001525	05.06.2014	57849008	AIR-CONDITIONING ECU	UPDATING	Km 16090
F	23	ROSSOCORSA S.R.L.	ROSSOCORSA S.R.L.	2014720	1	IT0002919	07.10.2014	57852004	DRIVER-SIDE FRONT DOOR NODE	UPDATING	Km 19315
F	23	ROSSOCORSA S.R.L.	ROSSOCORSA S.R.L.	2014720	2	IT0002919	07.10.2014	57931017	RH. FRONT DOOR UPPER HINGE	UPDATING	Km 19315
F	16	ROSSOCORSA S.R.L.	ROSSOCORSA S.R.L.	2014720	3	IT0002919	07.10.2014	57913003	REAR GUARD FOR FRONT RH WHEELH	NOISE, KNOCK	Km 19315
F	16	ROSSOCORSA S.R.L.	ROSSOCORSA S.R.L.	2014720	4	IT0002919	07.10.2014	57171001	NOURICE	LEAKS / BAD SEALING	Km 19315
F	23	ROSSOCORSA S.R.L.	ROSSOCORSA S.R.L.	2014964	1	IT0004008	23.12.2014	57130120	R.H. WASTE GATE CLIP	MISSING, LACKING	Km 21424
F	16	ROSSOCORSA S.R.L.	ROSSOCORSA S.R.L.	2014964	2	IT0004008	23.12.2014	57610001	RH FRONT UPPER LEVER	NOISE, KNOCK	Km 21424

1 / 3

检查车辆数据

BOL

在“BOL”工作表中，您可以找到为该车打开的 Blue on Line 请求信息。

Opening Date	Report SN	Status	Component Code	Description
05.03.2010	000000000146592	60	45912001	FRONT PARKING SENSOR
25.02.2011	000000000173176	60	45211001	CLUTCH MECHANISM
29.03.2012	000000000199121	60	45830001	RH HEADLIGHT COMPLETE

检查车辆数据

车辆配置更新

在“车辆配置更新”(Vehicle Configuration Update)工作表中，您可以找到有关车辆原始配置更改的信息。有关车辆配置更新的信息，请参阅“提交保修索赔并关闭保养条目”部分中包含的“车辆配置更新”程序。

The screenshot shows a software interface for vehicle configuration updates. At the top, there are three buttons: "1. Vehicle Entry", "2. Repair", and "3. Close". Below these is a navigation bar with tabs: "Vehicle Information", "Campaign", "Warranty", "BOL", "Vehicle Configuration Update", "Service Entry", "Customer Data", and "Maintenance". The "Vehicle Configuration Update" tab is active. Underneath, there is an "Input" section with a form containing three columns: "Part Number", "Description", and "Serial Number". Below the form, there is a note: "We recommend you to enclose the explanatory notes" and two buttons: "Add" and "Go To Non-genuine part/accessory". At the bottom, there is a table with the following data:

Part Number	Description	Serial Number	Note
670032183	CPL FRONT DIFFERENTIAL M161	13618	

At the bottom right of the table, it says "1 / 1". Below the table, there are navigation buttons: a left arrow, a double left arrow, a refresh icon, a double right arrow, and a right arrow.

检查车辆数据

保养条目

在“保养条目”工作表中，您可以找到为该车打开的所有保养条目的列表。

1. Vehicle Entry		2. Repair		3. Close					
Vehicle Entry									
Vehicle Information		Campaign	Warranty	BOL	Vehicle Configuration Update	Service Entry	Customer Data	Dossier list	Maintenance
Service Entry #	Repair Order#	Dealer	In		Out		Service Entry Status		
			Date	Mileage	Date	Mileage			
IT0000011	2014103	52222 ROSSOCORSA S.R.L.	07.01.2014	5466 K	21.04.2023	34423 K	Closed		
IT0000658	2014244	52222 ROSSOCORSA S.R.L.	13.03.2014	9277 K	17.03.2014	9286 K	Closed		
IT0000887	2862014	52222 ROSSOCORSA S.R.L.	02.04.2014	9382 K	08.04.2014	9390 K	Closed		
IT0001356	2014400	52222 ROSSOCORSA S.R.L.	15.05.2014	13513 K	16.05.2014	13522 K	Closed		
IT0001525	2014435	52222 ROSSOCORSA S.R.L.	03.06.2014	16083 K	05.06.2014	16090 K	Closed		
IT0002919	2014720	52222 ROSSOCORSA S.R.L.	30.09.2014	19307 K	07.10.2014	19315 K	Closed		
IT0004008	2014964	52222 ROSSOCORSA S.R.L.	22.12.2014	21424 K	23.12.2014	21424 K	Closed		
IT0013485	2016886	52222 ROSSOCORSA S.R.L.	15.06.2016	40081 K	18.07.2016	40100 K	Closed		
IT0019583	16817	52222 ROSSOCORSA S.R.L.	02.02.2017	57869 K	17.02.2017	57879 K	Closed		

1 / 1

Navigation icons: Home, Previous, Refresh, Next, End

检查车辆数据

客户数据

“客户数据” (Customer Data) 工作表显示了客户信息。

1. Vehicle Entry2. Repair3. Close

▶ Vehicle Entry

Vehicle InformationCampaignWarrantyBOLVehicle Configuration UpdateService EntryCustomer DataDossier listMaintenance

Customer Data

Sex * <input type="text" value="M"/>	Country of Residence <input type="text" value="Italy"/>
Company <input type="text"/>	Preferred language for contacts <input type="text"/>
Last Name * <input type="text" value="客户姓氏"/>	Address * <input type="text" value="Customer address"/>
First Name * <input type="text" value="客户名字"/>	City <input type="text" value="Milano"/>
Occupation <input type="text" value="Entrepreneur"/>	State <input type="text" value="MI - MILANO"/>
Occupation Notes <input type="text"/>	Zip Code <input type="text" value="20100"/>
E-Mail * <input type="text" value="xxxxx@xxxx.com"/> N/A <input type="checkbox"/>	Phone <input type="text" value="+ 39 123456789"/> N/A <input type="checkbox"/> Phone Type <input type="text" value="Mobile"/>

Your Maserati

Purchase Date * <input type="text" value="08.07.2010"/>	
Plate <input type="text"/>	

You can print the labels only for 90 days starting from the Service Entry opening date

CheckSavePrivacyPrint labels

检查车辆数据

档案列表

在“档案列表” (Dossier List) 工作表中，您可以找到与道路救援服务有关的 VIN 的可用档案列表。

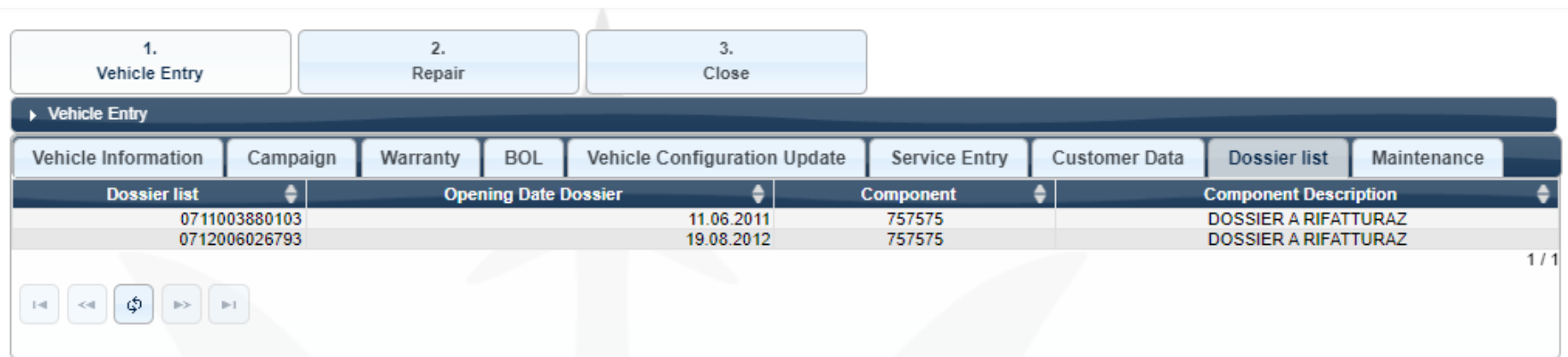

Vehicle Entry								
Vehicle Information	Campaign	Warranty	BOL	Vehicle Configuration Update	Service Entry	Customer Data	Dossier list	Maintenance
Dossier list	Opening Date Dossier	Component	Component Description					
0711003880103	11.06.2011	757575	DOSSIER A RIFATTURAZ					
0712006026793	19.08.2012	757575	DOSSIER A RIFATTURAZ					

1 / 1

检查车辆数据

保养

在“保养” (Maintenance) 工作表中，您可以找到有关车辆保养的信息。

1. Vehicle Entry		2. Repair		3. Close					
Vehicle Entry									
Vehicle Information		Campaign	Warranty	BOL	Vehicle Configuration Update	Service Entry	Customer Data	Dossier list	Maintenance
Type	Date in	Importer	Dealer	Service Entry #	Mileage In	Repair Order #	Component	Component Description	
Paid maintenance	25.11.2013	52222 ROSSOCORSA S.R.L.	52222 ROSSOCORSA S.R.L.	IT0000050	29597 K	2013649	46020020	INTERVENTION PAID BY CUSTOMER	
Paid maintenance	19.07.2012	52222 ROSSOCORSA S.R.L.	52222 ROSSOCORSA S.R.L.	0092368	20418 K	2012475	46010021	1ST SERVICE	
Paid maintenance	15.12.2011	52222 ROSSOCORSA S.R.L.	52222 ROSSOCORSA S.R.L.	0074309	16912 K	2011843	46020020	INTERVENTION PAID BY CUSTOMER	
Paid maintenance	29.06.2011	52222 ROSSOCORSA S.R.L.	52222 ROSSOCORSA S.R.L.	0060685	8484 K	2011478	46020020	INTERVENTION PAID BY CUSTOMER	

1 / 1

Navigation icons: Home, Previous, Refresh, Next, End

检查车辆数据

Maserati 互联

“Maserati 互联” (Maserati Connect) 工作表显示了有关“Maserati 互联”订阅状态的信息。有关连接“激活”和“返回新订阅”流程的更多信息，请参阅专门的“连接功能”部分。

Vehicle Information	Campaign	Warranty	BOL	Change of Ownership	Vehicle Configuration Update	Service Entry	Customer Data
Dossier list							
Maserati Connect							
Warning							
The registration process has been completed							
▼ Subscription							
ID Gigya	562e6bb3d22345f			Activation Date		2022-06-24 14:33	
Status	Subscription Active						
▼ Subscriber							
First Name	Sa	Last Name	Car	Phone Number			
Country	Italia	E-Mail	sar...m	Status	Full Registration		
Remove Subscription							



“Maserati 互联”功能仅适用于特定市场！



打开保养条目

打开保养条目

进入“车辆条目”工作表

要打开新的保养条目，请单击“保养条目插入”(Service Entry Insert) 菜单（路径：“售后服务”(Aftersales)\“保养条目”(Service Entry)\“保养条目插入”(Service Entry Insert)）。

ModisCS+ ROSSOCORSA - MILANO SERVICE ENTRY INSERT SAT Training (Aftersale)

1. Vehicle Entry 2. Repair 3. Close

▼ Vehicle Entry

Service Entry #	Opening date	Last Update	Days down	Vehicle Downtime	Previous Repair#
		-	0	0	

Status
-

Dealer
-

Chassis no. Plate # Customer Name Actual Owner
Yes No

Repair Order# Repair order opening date Mileage In Km M Vehicle towed in due to technical issues Yes No Loaner Car Yes No

Mobility services provided Yes No Open Customer Case Yes No Rental Car Yes No

Service Note
-

Inquiry

There are no warnings

打开保养条目

检索客户和车辆数据

在工作表“1.车辆条目”(1. Vehicle Entry) 中，输入底盘号或车牌号即可检索主要车辆数据。

1. Vehicle Entry2. Repair3. Close

▼ Vehicle Entry

Service Entry #	Opening date	Last Update	Days down	Vehicle Downtime	Previous Repair#
		-	0	1	

Status
-

Dealer
-

Chassis no.	Plate #	Last Update	Customer Name	Actual Owner
327800	FV358HT	LEVANTE S	客户姓名	Yes <input type="radio"/> No <input type="radio"/>

Repair Order#	Repair order opening date	Mileage In	Vehicle towed in due to technical issues	Loaner Car
		Km <input checked="" type="radio"/> M <input type="radio"/>	Yes <input type="radio"/> No <input type="radio"/>	Yes <input type="radio"/> No <input type="radio"/>

Mobility services provided
Yes No

Open Customer Case
Yes No

Rental Car
Yes No

Service Note

CheckSaveBulletinsKnowledge on Line

Warning
WW0370:No Open Campaigns for this vehicle
One or more Privacy consents are missing. Please present our Policy to the customer and request consents.

打开保养条目

输入主要访问信息

然后，输入与当前车间访问相关的所有请求数据：经销商（如果有更多项目可用）、维修单编号、维修单打开日期、进站里程。此外，您必须指出车辆是否由于技术问题而被拖走，并在“服务说明” (Service Note) 字段中插入客户要求的干预措施的简短概述。如果客户案例打开，系统会通知您。

1. Vehicle Entry2. Repair3. Close

Vehicle Entry

Service Entry #	Opening date	Last Update	Days down	Vehicle Downtime	Previous Repair#
		-	0	1	

Status
-

Dealer
052222 - ROSSOCORSA S.R.L.

Chassis no.	Plate #	Customer Name	Actual Owner
327800	FV358HT	LEVANTE S	客户姓名 Yes <input type="radio"/> No <input type="radio"/>

Repair Order#	Repair order opening date	Mileage In	Vehicle towed in due to technical issues
54321	16.11.2023	Km <input checked="" type="radio"/> M <input type="radio"/> 25200	Yes <input type="radio"/> No <input checked="" type="radio"/>

Mobility services provided
Yes No

Service Note
Leaking water radiator. Rear taillight damaged

Open Customer Case
Yes No

CheckSaveBulletinsKnowledge on Line



“维修单编号”、“维修单打开日期”和“进站里程”必须与当地 DMS（经销商管理系统）中登记的详细信息一致！

请记住，客户必须签署维修单才能授权进行干预！

打开保养条目

当车辆被标记为“车队车辆”时，如何正确填写客户详细信息

如果车辆被标记为“车队车辆”，则请确保在“客户数据”选项卡中填写完整、正确的用户（最终客户）信息。

Repair Order# 33389 Repair order opening date 10/01/2015 Mileage In Km M 44 Vehicle towed in due to technical issues Yes No Loaner Car Yes No Demo Car Yes No

Mobility services provided Yes No Open Customer Case Yes No

Fleet Vehicle Yes No

Service Note MIRROR CAP

Back to list Save Vehicle Report Bulletins Knowledge on Line

Warning
WW0747:RegularWarranty to be started or RepairDate less than Reg.Wty Start Date
WW0370:No Open Campaigns for this vehicle
Vehicle with more than 10 visits in the workshop

Vehicle Information Campaign Warranty BOL Vehicle Configuration Update Service Entry **Customer Data** Maintenance

Customer Data

Sex * Company DADA Last Name * ESSA First Name * KHALED Occupation Entrepreneur Occupation Notes E-Mail * nlazzari@maserationtario.com N/A Country of Residence Canada Preferred language for contacts Address * 200 AUTO PARK CIRCLE City VAUGHAN State ONTARIO Zip Code L4L8R1 Phone 4168597686 N/A Phone Type Mobile

Your Maserati
Purchase Date * 12/01/2018 Plate

You can print the labels only for 90 days starting from the Service Entry opening date

Check Save Privacy Print labels



应正确填写“客户数据”选项卡，首先填写公司名称，然后填写完整的客户详细信息。

打开保养条目

所有权变更

您必须指出“客户名称”(Customer Name) 字段中报告的客户是否为当前客户。

如果您单击“否”(NO)，将出现一个弹出窗口，要求您确认选择。

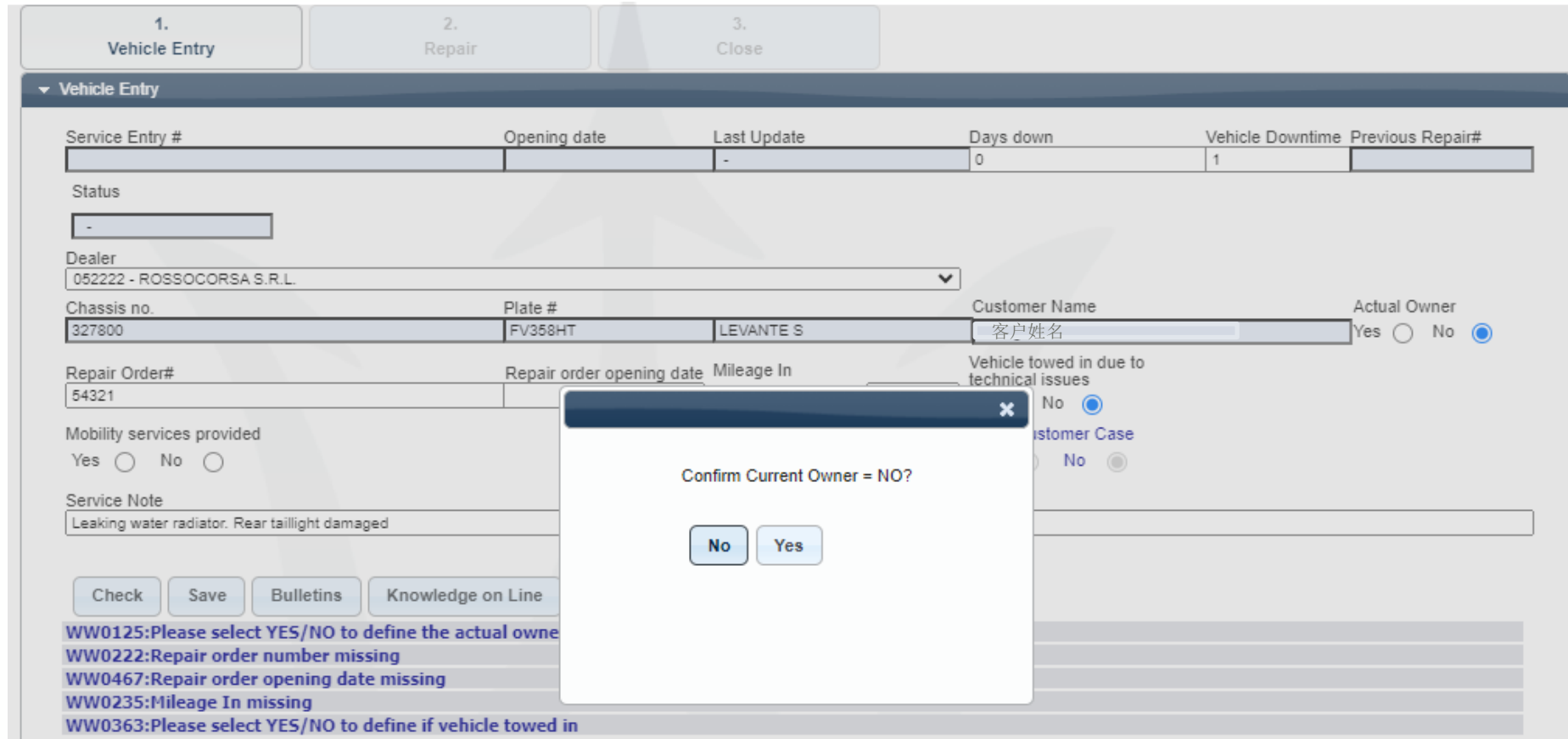

The screenshot shows a web interface for entering vehicle repair information. At the top, there are three tabs: "1. Vehicle Entry", "2. Repair", and "3. Close". The "Vehicle Entry" tab is active. Below the tabs, there is a form with several fields:

- Service Entry #**: [Empty]
- Opening date**: [Empty]
- Last Update**: [-]
- Days down**: [0]
- Vehicle Downtime**: [1]
- Previous Repair#**: [Empty]
- Status**: [-]
- Dealer**: [052222 - ROSSOCORSA S.R.L.]
- Chassis no.**: [327800]
- Plate #**: [FV358HT]
- Customer Name**: [客户姓名]
- Actual Owner**: Yes No
- Repair Order#**: [54321]
- Repair order opening date**: [Empty]
- Mileage In**: [Empty]
- Vehicle towed in due to technical issues**: No Yes
- Mobility services provided**: Yes No
- Service Note**: [Leaking water radiator. Rear taillight damaged]

A modal dialog box is open in the center of the screen with the title "Confirm Current Owner = NO?". It contains two buttons: "No" and "Yes".

At the bottom of the form, there are several buttons: "Check", "Save", "Bulletins", and "Knowledge on Line". Below these buttons, there are several lines of text in blue, which appear to be error messages or warnings:

- WW0125:Please select YES/NO to define the actual owner
- WW0222:Repair order number missing
- WW0467:Repair order opening date missing
- WW0235:Mileage In missing
- WW0363:Please select YES/NO to define if vehicle towed in

打开保养条目

所有权变更

如果您确认“车辆条目”工作表中报告的客户不是当前客户，将出现一条信息性消息，提醒您向客户介绍隐私政策并征得其同意。

1. Vehicle Entry 2. Repair 3. Close

Vehicle Entry

Service Entry #	Opening date	Last Update	Days down	Vehicle Downtime	Previous Repair#
		-	0	1	2

Status
-

Dealer
052222 - ROSSOCORSA S.R.L.

Chassis no.	Plate #	Customer Name	Actual Owner
327800	FV358HT	客户姓名	Yes <input type="radio"/> No <input checked="" type="radio"/>

Repair Order# 54321 Repair order opening date 16.11.2023 Mileage In Km M 25200

Mobility services provided
Yes No Select options

Fleet Vehicle
Yes No

Vehicle towed in due to technical issues
Yes No

Open Customer Case
Yes No

Service Note
Leaking water radiator. Rear taillight damaged

Check Save Bulletins Knowledge on Line

WW1211:Attention: select the provided mobility services

Warning
WW0370:No Open Campaigns for this vehicle
One or more Privacy consents are missing. Please present our Policy to the customer and request consents.

打开保养条目

所有权变更

确认车辆有新车主后，您必须更新“所有权变更”(Change of Ownership) 工作表中的客户信息，该表会在您尝试保存保养条目时出现。

The screenshot displays a software interface for vehicle management. At the top, there are three numbered buttons: '1. Vehicle Entry', '2. Repair', and '3. Close'. Below these is a dark blue header bar with a dropdown arrow and the text 'Vehicle Entry'. Underneath the header is a horizontal menu with several tabs: 'Vehicle Information', 'Campaign', 'Warranty', 'BO', 'Change of Ownership', 'Vehicle Configuration Update', 'Service Entry', and 'Maintenance'. The 'Change of Ownership' tab is highlighted with a blue rectangular box. Below the menu is a section titled 'Customer Search' with a dropdown arrow. It contains a text input field with the placeholder 'Enter Last name (or part of last name)', a label 'Last Name', and an empty text box. At the bottom of this section are two buttons: 'Dealer Data' and 'Search'.

打开保养条目

所有权变更

在“所有权变更”(Change of Ownership)工作表中，输入客户姓氏，然后单击“搜索”(Search)按钮，检查该客户是否已经存在于“工厂”数据库中。

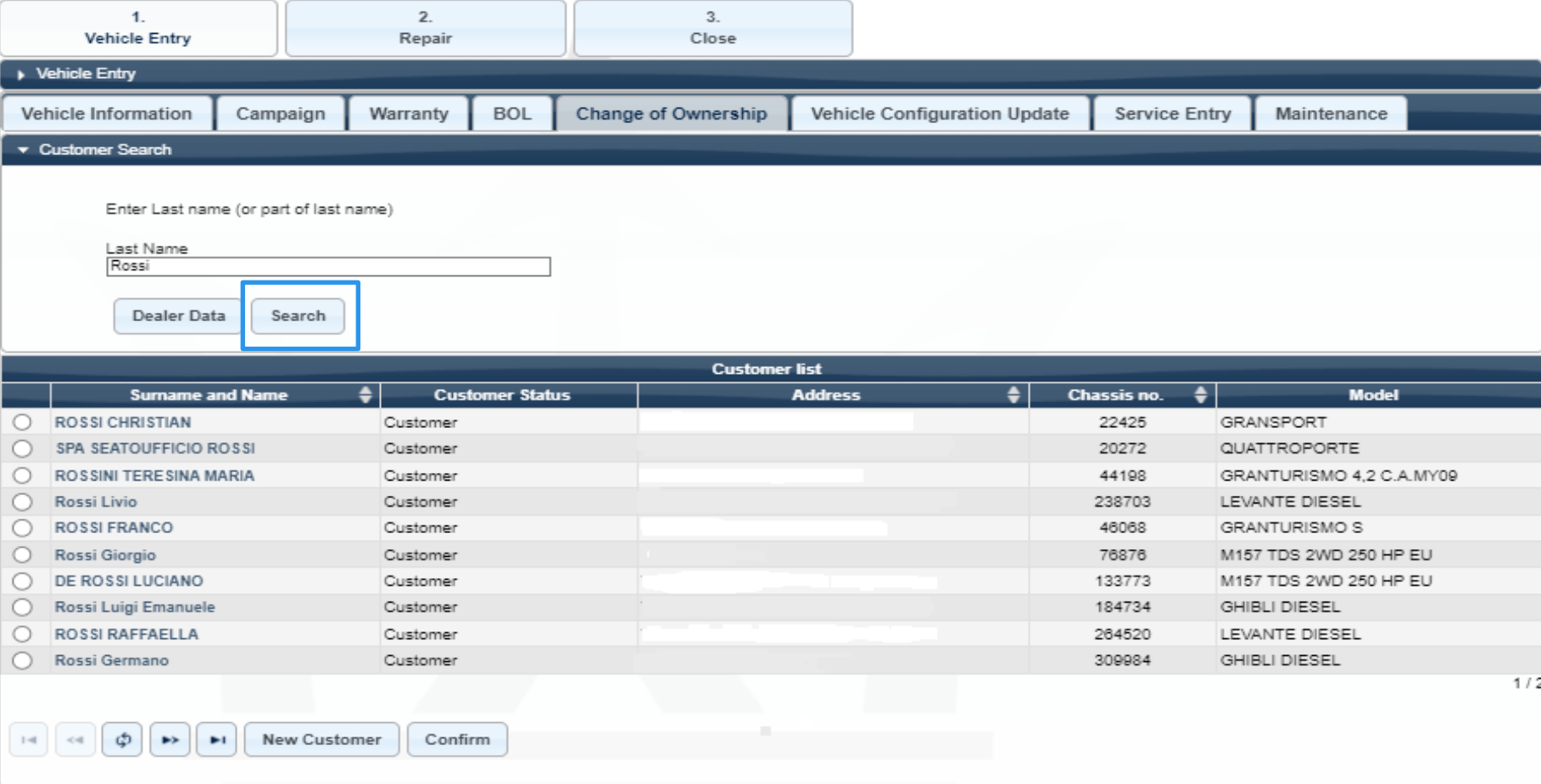

The screenshot shows a software interface for vehicle management. At the top, there are three tabs: '1. Vehicle Entry', '2. Repair', and '3. Close'. Below these is a navigation bar with several options: 'Vehicle Information', 'Campaign', 'Warranty', 'BOL', 'Change of Ownership', 'Vehicle Configuration Update', 'Service Entry', and 'Maintenance'. The 'Change of Ownership' tab is selected. Underneath, there is a 'Customer Search' section with a text input field labeled 'Enter Last name (or part of last name)'. The input field contains the text 'Last Name' and 'Rossi'. Below the input field are two buttons: 'Dealer Data' and 'Search'. The 'Search' button is highlighted with a blue box. Below the search section is a table titled 'Customer list' with the following columns: 'Surname and Name', 'Customer Status', 'Address', 'Chassis no.', and 'Model'. The table contains 10 rows of customer data. At the bottom of the interface, there are navigation buttons: '<=>', '<<=>', '<=>', '>>=>', 'New Customer', and 'Confirm'. The page number '1 / 2' is visible in the bottom right corner.

	Surname and Name	Customer Status	Address	Chassis no.	Model
<input type="radio"/>	ROSSI CHRISTIAN	Customer		22425	GRANSPORT
<input type="radio"/>	SPA SEATOUFFICIO ROSSI	Customer		20272	QUATTROPORTE
<input type="radio"/>	ROSSINI TERE SINA MARIA	Customer		44198	GRANTURISMO 4,2 C.A.MY09
<input type="radio"/>	Rossi Livio	Customer		238703	LEVANTE DIESEL
<input type="radio"/>	ROSSI FRANCO	Customer		46068	GRANTURISMO S
<input type="radio"/>	Rossi Giorgio	Customer		76876	M157 TDS 2WD 250 HP EU
<input type="radio"/>	DE ROSSI LUCIANO	Customer		133773	M157 TDS 2WD 250 HP EU
<input type="radio"/>	Rossi Luigi Emanuele	Customer		184734	GHIBLI DIESEL
<input type="radio"/>	ROSSI RAFFAELLA	Customer		264520	LEVANTE DIESEL
<input type="radio"/>	Rossi Germano	Customer		309984	GHIBLI DIESEL

打开保养条目

所有权变更

如果因为该客户是或已经是 Maserati 车主，而在数据库中找到匹配项，请选择该客户姓名并单击“确认” (Confirm)。

The screenshot shows a software interface for vehicle management. At the top, there are three tabs: '1. Vehicle Entry', '2. Repair', and '3. Close'. Below these is a navigation bar with several options: 'Vehicle Information', 'Campaign', 'Warranty', 'BOL', 'Change of Ownership', 'Vehicle Configuration Update', 'Service Entry', and 'Maintenance'. The 'Customer Search' section is expanded, showing a search field for 'Last Name' with 'Rossi' entered. Below the search field are 'Dealer Data' and 'Search' buttons. A table titled 'Customer list' displays the following data:

	Surname and Name	Customer Status	Address	Chassis no.	Model
<input type="radio"/>	ROSSI CHRISTIAN	Customer		22425	GRANSPORT
<input type="radio"/>	SPA SEATOUFFICIO ROSSI	Customer		20272	QUATTROPORTE
<input type="radio"/>	ROSSINI TERESINA MARIA	Customer		44198	GRANTURISMO 4,2 C.A.MY09
<input type="radio"/>	Rossi Livio	Customer		238703	LEVANTE DIESEL
<input type="radio"/>	ROSSI FRANCO	Customer		48088	GRANTURISMO S
<input checked="" type="radio"/>	Rossi Giorgio	Customer		78876	M157 TDS 2WD 250 HP EU
<input type="radio"/>	DE ROSSI LUCIANO	Customer		133773	M157 TDS 2WD 250 HP EU
<input type="radio"/>	Rossi Luigi Emanuele	Customer		184734	GIBLI DIESEL
<input type="radio"/>	ROSSI RAFFAELLA	Customer		264520	LEVANTE DIESEL
<input type="radio"/>	Rossi Germano	Customer		309984	GIBLI DIESEL

At the bottom of the interface, there are navigation buttons: '<=>', '<<=>', '<=>', '>>=>', '>=>', 'New Customer', and 'Confirm'. The 'Confirm' button is highlighted with a red box.

打开保养条目

所有权变更

单击“确认”后，如果需要，您可以查看和更新数据。

The screenshot displays a web interface for entering service data. At the top, there are three tabs: '1. Vehicle Entry', '2. Repair', and '3. Close'. Below these is a navigation bar with tabs for 'Vehicle Information', 'Campaign', 'Warranty', 'BOL', 'Change of Ownership', 'Vehicle Configuration Update', 'Service Entry', and 'Maintenance'. The 'Change of Ownership' section is active and contains the following fields:

Sex *	M	Country of Residence	Italy
Company		Preferred language for contacts	
Last Name *	客户姓氏	Address *	
First Name *	客户名字	City	Milano
Occupation	Entrepreneur	State	MI - MILANO
Occupation Notes		Zip Code	201xxx
E-Mail *	giorgio.rossi@xxx.it	Phone	18612401868
	N/A <input type="checkbox"/>		N/A <input type="checkbox"/>
		Phone Type	Mobile

Below this, the 'Your Maserati' section includes:

Purchase Date *	10.10.2023
Plate	

A pink banner below the form states: "You can print the labels only for 90 days starting from the Service Entry opening date". At the bottom, there are buttons for 'Check', 'Save', 'Back', 'Privacy', and 'Print labels'.

打开保养条目

所有权变更

如果没有找到匹配项，请单击“新客户” (New Customer) 按钮。

1. Vehicle Entry 2. Repair 3. Close

Vehicle Entry

Vehicle Information Campaign Warranty BOL Change of Ownership Vehicle Configuration Update Service Entry Maintenance

Customer Search

Enter Last name (or part of last name)

Last Name
Rossi

Dealer Data Search

	Surname and Name	Customer Status	Address	Chassis no.	Model
<input type="radio"/>	ROSSI CHRISTIAN	Customer		22425	GRANSPORT
<input type="radio"/>	SPA SEATOUFFICIO ROSSI	Customer		20272	QUATTROPORTE
<input type="radio"/>	ROSSINI TERESINA MARIA	Customer		44198	GRANTURISMO 4,2 C.A.MY09
<input type="radio"/>	Rossi Livio	Customer		238703	LEVANTE DIESEL
<input type="radio"/>	ROSSI FRANCO	Customer		48088	GRANTURISMO S
<input type="radio"/>	Rossi Giorgio	Customer		78876	M157 TDS 2WD 250 HP EU
<input type="radio"/>	DE ROSSI LUCIANO	Customer		133773	M157 TDS 2WD 250 HP EU
<input type="radio"/>	Rossi Luigi Emanuele	Customer		184734	GIBLI DIESEL
<input type="radio"/>	ROSSI RAFFAELLA	Customer		264520	LEVANTE DIESEL
<input type="radio"/>	Rossi Germano	Customer		309984	GIBLI DIESEL

1 / 2

Navigation: [Home] [Previous] [Refresh] [Next] [Last] [New Customer] [Confirm]

打开保养条目

所有权变更

单击“新客户”按钮后，会出现一个窗口，您必须在其中插入新客户的数据。必填字段标有“*”。

1. Vehicle Entry 2. Repair 3. Close

Vehicle Entry

Vehicle Information Campaign Warranty BOL Change of Ownership Vehicle Configuration Update Service Entry Maintenance

Change of Ownership

Sex * Country of Residence
Company Preferred language for contacts
Last Name *
First Name *
Occupation Occupation Notes
E-Mail * N/A Phone N/A Phone Type

Your Maserati

Purchase Date *
Plate

You can print the labels only for 90 days starting from the Service Entry opening date

Check Save Back Privacy Print labels



在未输入新客户详细信息之前，您可以更改“车辆条目”工作表中的“实际车主”标记。插入数据后，要更改选择，必须打开IT请求。

打开保养条目

所有权变更

输入新客户的所有相关信息后，单击“隐私” (Privacy) 记录客户偏好。

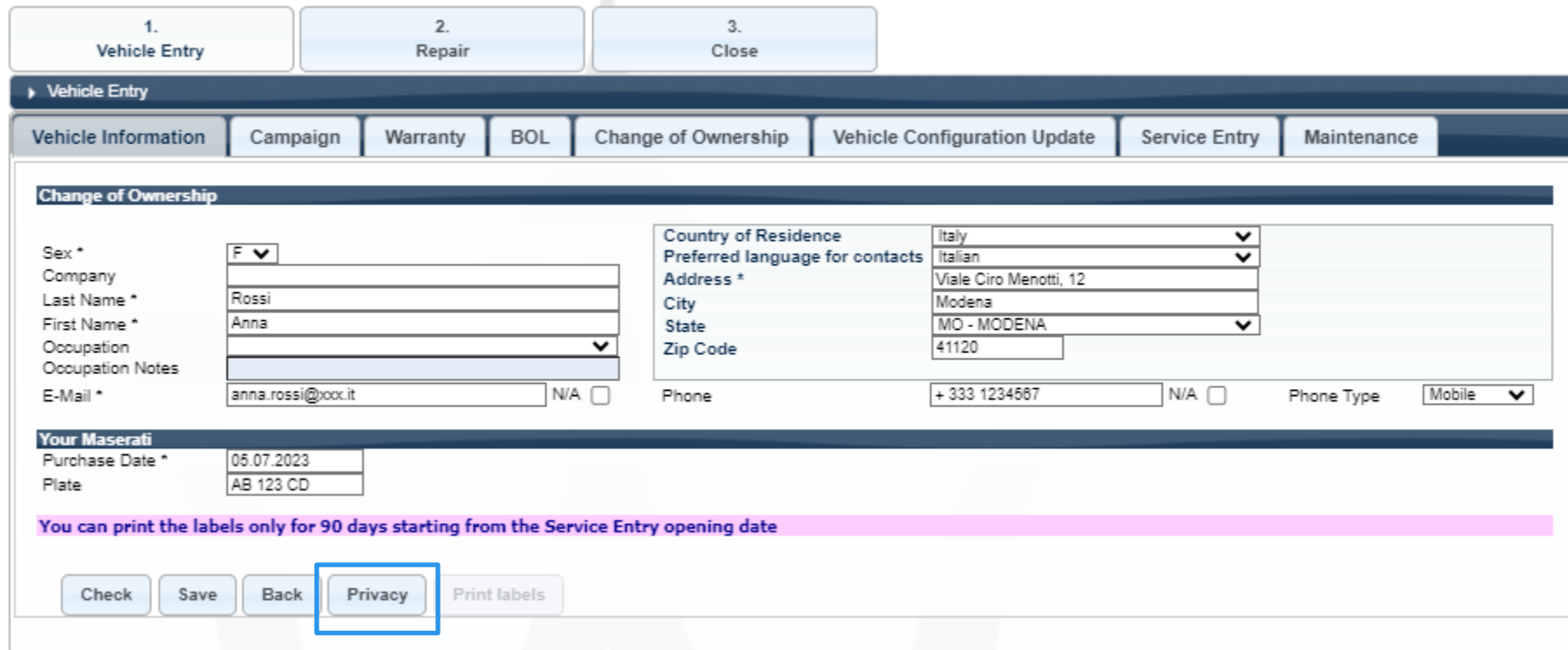

The screenshot displays a web interface for entering vehicle information. At the top, there are three tabs: '1. Vehicle Entry', '2. Repair', and '3. Close'. Below these is a navigation bar with several menu items: 'Vehicle Information', 'Campaign', 'Warranty', 'BOL', 'Change of Ownership', 'Vehicle Configuration Update', 'Service Entry', and 'Maintenance'. The 'Change of Ownership' section is active and contains the following fields:

Sex *	F	Country of Residence	Italy
Company		Preferred language for contacts	Italian
Last Name *	Rossi	Address *	Viale Ciro Menotti, 12
First Name *	Anna	City	Modena
Occupation		State	MO - MODENA
Occupation Notes		Zip Code	41120
E-Mail *	anna.rossi@xxx.it	Phone	+ 333 1234567
	N/A <input type="checkbox"/>		N/A <input type="checkbox"/>
		Phone Type	Mobile

Below the 'Change of Ownership' section is the 'Your Maserati' section:

Purchase Date *	05.07.2023
Plate	AB 123 CD

A pink banner below the 'Your Maserati' section reads: "You can print the labels only for 90 days starting from the Service Entry opening date". At the bottom of the form, there are five buttons: 'Check', 'Save', 'Back', 'Privacy', and 'Print labels'. The 'Privacy' button is highlighted with a blue box.

打开保养条目

所有权变更

单击“隐私”后，会出现一个新窗口。

在提交隐私授权之前，根据客户偏好更新此部分。单击“[单击此处](#)”，选择订阅的通信偏好。

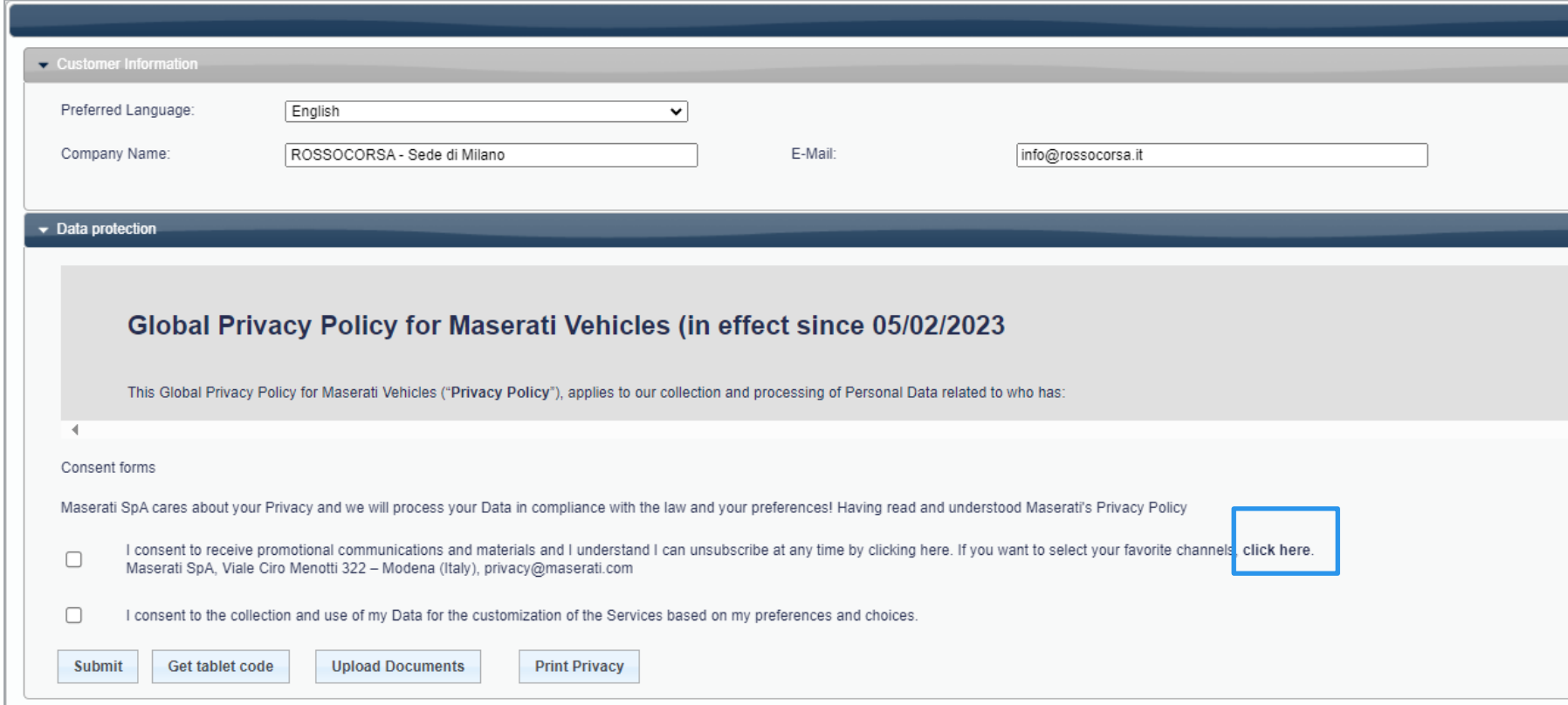

Customer Information

Preferred Language:

Company Name: E-Mail:

Data protection

Global Privacy Policy for Maserati Vehicles (in effect since 05/02/2023)

This Global Privacy Policy for Maserati Vehicles ("Privacy Policy"), applies to our collection and processing of Personal Data related to who has:

Consent forms

Maserati SpA cares about your Privacy and we will process your Data in compliance with the law and your preferences! Having read and understood Maserati's Privacy Policy

I consent to receive promotional communications and materials and I understand I can unsubscribe at any time by clicking here. If you want to select your favorite channels [click here.](#)

I consent to the collection and use of my Data for the customization of the Services based on my preferences and choices.

打开保养条目

所有权变更

单击“隐私”后，会出现一个新窗口。

选择客户所需的通信选项后，单击“提交”，然后关闭窗口，返回到客户数据部分。

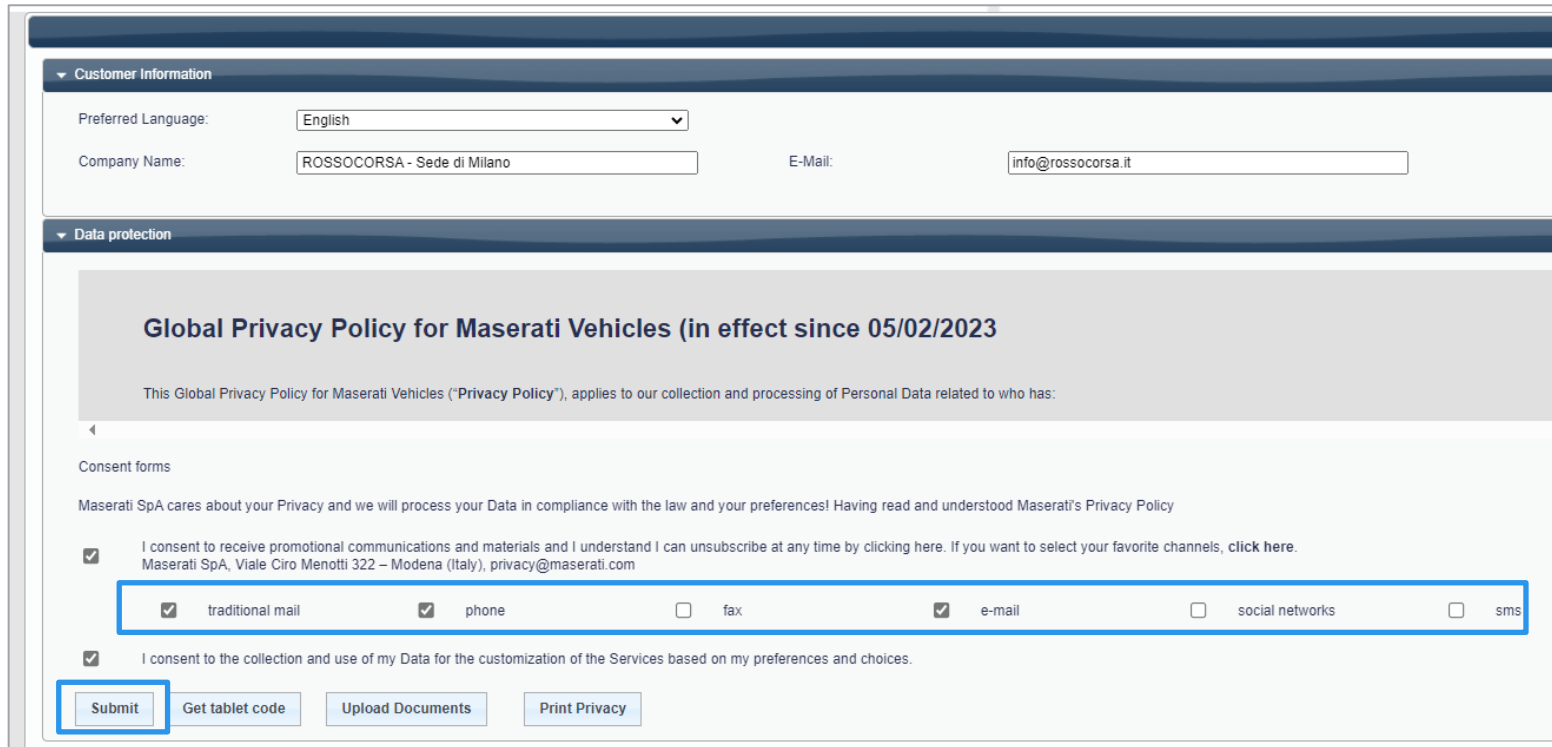

The screenshot displays a web form with two main sections: 'Customer Information' and 'Data protection'. In the 'Customer Information' section, there are fields for 'Preferred Language' (set to English), 'Company Name' (ROSSOCORSA - Sede di Milano), and 'E-Mail' (info@rossocorsa.it). The 'Data protection' section features a heading 'Global Privacy Policy for Maserati Vehicles (in effect since 05/02/2023)' and a paragraph explaining the policy. Below this, there is a 'Consent forms' section with a checkbox for 'I consent to receive promotional communications...' and a row of communication preferences: 'traditional mail' (checked), 'phone' (checked), 'fax' (unchecked), 'e-mail' (checked), 'social networks' (unchecked), and 'sms' (unchecked). At the bottom, there is another checkbox for 'I consent to the collection and use of my Data...' and a row of buttons: 'Submit', 'Get tablet code', 'Upload Documents', and 'Print Privacy'. The 'Submit' button is highlighted with a blue border.



要填写此部分，请参阅通函 MAS002029 “Modis+ 中的新隐私警告”和 MAS003234 “以客户为中心 - 隐私同意书”以及随附文件中的信息

打开保养条目

所有权变更

更新“隐私”部分后，单击“保存”(Save)完成数据输入。

完成后，将出现“数据成功输入”(Data successfully entered)消息。

1. Vehicle Entry 2. Repair 3. Close

Vehicle Entry

Vehicle Information Campaign Warranty BOL Change of Ownership Vehicle Configuration Update Service Entry Maintenance

Change of Ownership

Sex * F ▼
Company
Last Name * Rossi
First Name * Anna
Occupation ▼
Occupation Notes
E-Mail * anna.rossi@xxx.it N/A Phone 3331234567 N/A Phone Type Mobile ▼

Country of Residence East Timor ▼
Preferred language for contacts English ▼
Address * Viale Ciro Menotti, 12
City Modena
State MO
Zip Code 41120

Your Maserati

Purchase Date * 05.07.2023
Plate AB 123 CD

You can print the labels only for 90 days starting from the Service Entry opening date

Data successfully entered

Check Save Privacy Print labels

打开保养条目

所有权变更

完成所有权变更程序后，将出现“客户数据”(Customer data) 选项卡。

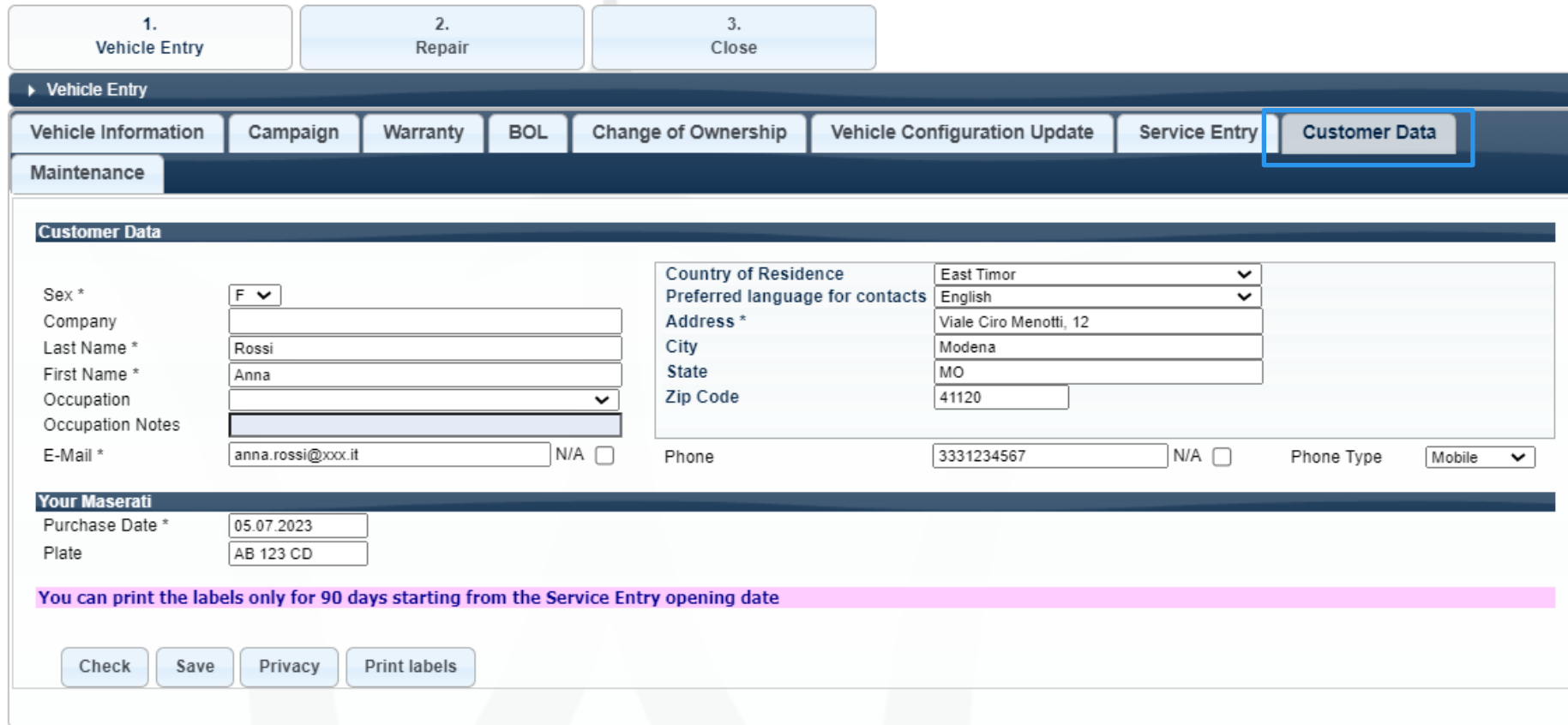

The screenshot displays a web interface for entering vehicle service information. At the top, there are three main steps: 1. Vehicle Entry, 2. Repair, and 3. Close. Below this, a navigation bar contains several tabs: Vehicle Information, Campaign, Warranty, BOL, Change of Ownership, Vehicle Configuration Update, Service Entry, and Customer Data. The 'Customer Data' tab is highlighted with a blue border. Underneath, there is a 'Maintenance' section with a 'Customer Data' sub-section. This section contains various input fields for customer information, including Sex, Company, Last Name, First Name, Occupation, Occupation Notes, E-Mail, Country of Residence, Preferred language for contacts, Address, City, State, Zip Code, Phone, and Phone Type. Below the customer data, there is a 'Your Maserati' section with fields for Purchase Date and Plate. A pink banner at the bottom of the form states: 'You can print the labels only for 90 days starting from the Service Entry opening date'. At the very bottom, there are four buttons: Check, Save, Privacy, and Print labels.

Customer Data	
Sex *	F
Company	
Last Name *	Rossi
First Name *	Anna
Occupation	
Occupation Notes	
E-Mail *	anna.rossi@xxx.it
Country of Residence	East Timor
Preferred language for contacts	English
Address *	Viale Ciro Menotti, 12
City	Modena
State	MO
Zip Code	41120
Phone	3331234567
Phone Type	Mobile

Your Maserati	
Purchase Date *	05.07.2023
Plate	AB 123 CD

You can print the labels only for 90 days starting from the Service Entry opening date

Check Save Privacy Print labels

打开保养条目

所有权变更

如果车辆尚未零售，系统将默认为“不适用”(N/A)：工厂数据库中没有可用信息。

Service Entry #	Opening date	Last Update	Days down	Vehicle Downtime	Previous Repair#
		-	0	0	

Status: -

Dealer: -

Chassis no.	Plate #	Customer Name	Actual Owner
354880		LEVANTE	Yes <input type="radio"/> No <input type="radio"/> N/A <input checked="" type="checkbox"/>

Repair Order#: Repair order opening date: Mileage In: Km M Vehicle towed in due to technical issues: Yes No

Service Note:

Buttons: Check, Save, Bulletins, Knowledge on Line

Warning: WW0370: No Open Campaigns for this vehicle. If the flag "actual owner" was incorrectly selected, please contact ABM/RAM

打开保养条目

所有权变更

如果现在可以更新详细信息，则取消勾选“不适用”(N/A) 复选框，系统将自动勾选单选按钮“否”(NO)，并要求按照“所有权变更”小节中所示的程序输入新客户的详细信息。

1. Vehicle Entry 2. Repair 3. Close

Vehicle Entry

Service Entry #	Opening date	Last Update	Days down	Vehicle Downtime	Previous Repair#
		-	0	0	

Status
-

Dealer
-

Chassis no. Plate # Customer Name Actual Owner

354880 LEVANTE Yes No N/A

Repair Order# Repair order opening date Mileage In Vehicle towed in due to technical issues

 Km M Yes No

Service Note

Check Save Bulletins Knowledge on Line

Warning
WW0370: No Open Campaigns for this vehicle
If the flag "actual owner" was incorrectly selected, please contact ABM/RAM

打开保养条目

提供的移动服务

要保存“保养条目”，还必须选择“是”(YES)或“否”(NO)以声明是否向客户提供了移动服务。

选择后，即根据所作选择出现一个弹出窗口。

在选择“是”(YES)的情况下：

- Maserati 代步车
- 其他品牌代步车
- 租赁车辆
- 公共交通工具（出租车、火车等）
- 接送服务
- 替代交通工具（送客户回家等）

The screenshot shows a web-based form for entering a service entry. At the top, there are three tabs: "1. Vehicle Entry", "2. Repair", and "3. Close". The "Vehicle Entry" tab is active. The form contains several fields and sections:

- Service Entry #**: [Empty]
- Opening date**: [Empty]
- Last Update**: [-]
- Days down**: [0]
- Vehicle Downtime**: [1]
- Previous Repair#**: [2]
- Status**: [-]
- Dealer**: [052222 - ROSSOCORSA S.R.L.]
- Chassis no.**: [327800]
- Plate #**: [FV358HT]
- Customer Name**: [客户姓名]
- Actual Owner**: [Yes No
- Repair Order#**: [54321]
- Repair order opening date**: [16.11.2023]
- Mileage In**: [25200] (Unit: Km M)
- Vehicle towed in due to technical issues**: [Yes No
- Open Customer Case**: [Yes No
- Mobility services provided**: [Yes No
- Fleet Vehicle**: [Yes No
- Service Note**: [Leaking water radiator. Rear taillight damaged]
- Select options** (dropdown menu):
 - Maserati Loaner Car
 - Another brand loaner car
 - Rental Car
 - Public Transportation
 - Pick up & delivery
 - ...

At the bottom, there are buttons for "Check", "Save", "Bulletins", and "Knowledge on". Below the buttons, there are two warning messages:

- WW1211:Attention: select the provided mobility ser**
- WW0370:No Open Campaigns for this vehicle**
- One or more Privacy consents are missing. Please present our Policy to the customer and request consents.**

打开保养条目

提供的移动服务

如果您选择“是”(YES)，然后在可用项目中选择“Maserati 代步车”(Maserati Loaner Car) 和/或“租赁车辆”(Rental Car)，则“代步车”和/或“租赁车辆”按钮将激活，您可以选择其提供的服务。

1. Vehicle Entry | 2. Repair | 3. Close

Vehicle Entry

WW0221: Mileage > Km 150000
WW0261: This car covers on average over 100 km per day

Service Entry #	Opening date	Last Update	Days down	Vehicle Downtime	Previous Repair#
IT0098594	06.10.2023	27.11.2023 - WBTESTHQ2	53	2	4

Service Entry Status: Open Repair in Progress

Dealer: 052222 - ROSSOCORSA S.R.L.

Chassis no.: 392207 | Plate #: rddd44 | Customer Name: LEVANTE HYBRID | Actual Owner: Yes No N/A

Repair Order#: 89561 | Repair order opening date: 06.10.2023 | Mileage In: Km M 150009

Vehicle towed in due to technical issues: Yes No

Open Customer Case: Yes No

Mobility services provided: Yes No

Service Note:

2 selected

- Maserati Loaner Car
- Another brand loaner car
- Rental Car
- Public Transportation
- Pick up & delivery
- ...

Loaner Car: Yes No

Rental Car: Yes No

Buttons: Back to list, Check, Save, Vehicle Report, On Line

Warning: WW0656: The VIN has been previously repaired on... WW0370: No Open Campaigns for this vehicle. There is no Maserati Connect active subscription for... for the registration process.



“代步车”和“租赁车辆”的相关功能仅适用于特定市场！

打开保养条目

提供的移动服务

对于代步车，选择“代步车” (Loaner Car) = “是” (Yes) 后，将出现一个新的“代步车” (Loaner Car) 选项卡。要正确填写该工作表中的信息，请参阅本手册的“更换车辆管理”部分。

The screenshot displays the 'Vehicle Entry' form in a software application. At the top, there are three tabs: '1. Vehicle Entry', '2. Repair', and '3. Close'. The 'Vehicle Entry' tab is active, showing a summary of a service entry for vehicle WW0221 (Mileage > Km 150000) and WW0261 (This car covers on average over 100 km per day). A table lists service entry details:

Service Entry #	Opening date	Last Update	Days down	Vehicle Downtime	Previous Repair#
IT0098594	06.10.2023	27.11.2023 - WBTESTHQ2	53	2	4

Below the table, there are buttons for 'Service Entry Status' and 'Status Changes'. The status is currently 'Open'. The dealer is '052222 - ROSSOCORSA S.R.L.'. The chassis number is '392207', plate is 'rrddd44', and the vehicle is a 'LEVANTE HYBRID'. The customer name is blank, and the actual owner is 'N/A'. The repair order number is '89561', and the repair order opening date is '06.10.2023'. The mileage in is '150009'. There are radio buttons for 'Vehicle towed in due to technical issues' (Yes/No), 'Loaner Car' (Yes/No), and 'Open Customer Case' (Yes/No). A dropdown menu is open, showing '1 selected' and 'Maserati Loaner Car' is checked. Other options include 'Another brand loaner car', 'Rental Car', 'Public Transportation', and 'Pick up & delivery'. At the bottom, there are buttons for 'Back to list', 'Check', 'Save', and 'Vehicle Report'. A warning message is displayed: 'Warning WW0656: The VIN has been previously repaired on WW0370: No Open Campaigns for this vehicle. There is no Maserati Connect active subscription for this vehicle. Please contact the dealer for the registration process.' The bottom navigation bar includes 'Vehicle Information', 'Campaign', 'Warranty', 'BOL', 'Vehicle Configuration Update', 'Service Entry', 'Loaner Car', 'Maserati Connect', and 'Maintenance'. The 'Loaner Car' tab is highlighted with a blue box.



代步车的相关功能仅适用于特定市场！

打开保养条目

提供的移动服务

对于租赁车辆，选择“租赁车辆” (Rental Car) = “是” (Yes) 后，将出现一个新的“租赁车辆” (Loaner Car) 选项卡。要正确填写该工作表中的信息，请参阅本手册的“更换车辆管理”部分。

1. Vehicle Entry 2. Repair 3. Close

Vehicle Entry

WW0221: Mileage > Km 150000
WW0261: This car covers on average over 100 km per day

Service Entry #	Opening date	Last Update	Days down	Vehicle Downtime	Previous Repair#
IT0098594	06.10.2023	27.11.2023 - WBTESTHQ2	53	2	4

Service Entry Status: - Open Repair in Progress

Dealer: 052222 - ROSSOCORSA S.R.L.

Chassis no.: 392207 Plate #: mddd44 Customer Name: LEVANTE HYBRID Actual Owner: Yes No N/A

Repair Order#: 89561 Repair order opening date: 06.10.2023 Mileage In: Km M 150009

Vehicle towed in due to technical issues: Yes No

Open Customer Case: Yes No

Loaner Car: Yes No

Rental Car: Yes No

Mobility services provided: Yes No

Service Note:

1 selected

- Maserati Loaner Car
- Another brand loaner car
- Rental Car
- Public Transportation
- Pick up & delivery
- Maserati Connect active subscription for the registration process.

Warning: WW0656: The VIN has been previously repaired on...
WW0370: No Open Campaigns for this vehicle
There is no Maserati Connect active subscription for...

Vehicle Information Campaign Warranty BOL Vehicle Configuration Update Service Entry Rental Car Maserati Connect Maintenance

Vehicle Information			Finish		
Chassis no.	392207		External Color	94084201	BIANCO
Vehicle	861170000	L4 MHEV 330HP EUROPEGT	Internal Color	94084354	BLACK/RED
VIN	7N6A1161R00Y302207		Camats	94084345	BLACK/BLACK/RED



租赁车辆的相关功能仅适用于特定市场！

打开保养条目

提供的移动服务

如果您没有提供移动服务，现在单击“否”(NO)，您必须说明原因：

- 未提供
- 提供但不符合客户需求
- 提供但不需要

1. Vehicle Entry2. Repair3. Close

Vehicle Entry

Service Entry #	Opening date	Last Update	Days down	Vehicle Downtime	Previous Repair#
		-	0	1	2

Status
-

Dealer
052222 - ROSSOCORSA S.R.L.

Chassis no.	Plate #	LEVANTE S	Customer Name	Actual Owner
327800	FV358HT	LEVANTE S	客户姓名	Yes <input type="radio"/> No <input checked="" type="radio"/>

Repair Order#	Repair order opening date	Mileage In	Vehicle towed in due to technical issues
54321	16.11.2023	Km <input checked="" type="radio"/> M <input type="radio"/> 25200	Yes <input type="radio"/> No <input checked="" type="radio"/>

Mobility services provided
Yes No

Fleet Vehicle
Yes No

Service Note
Leaking water radiator. Rear taillight damaged

▼

Not Offered

Not in line with Cust. need

Offered but not needed

Open Customer Case
Yes No

CheckSaveBulletinsKnowledge on Line

WW1211:Attention: select the provided mobility services

Warning

WW0370:No Open Campaigns for this vehicle

One or more Privacy consents are missing. Please present our Policy to the customer and request consents.

打开保养条目

提供的移动服务

如果缺少有关所提供的移动服务的信息，您将收到一条阻止消息。

1. Vehicle Entry2. Repair3. Close

Vehicle Entry

Service Entry #	Opening date	Last Update	Days down	Vehicle Downtime	Previous Repair#
		-	0	1	2

Status
-

Dealer
052222 - ROSSOCORSA S.R.L.

Chassis no.	Plate #	LEVANTE S	Customer Name	Actual Owner
327800	FV358HT	LEVANTE S	客户姓名	Yes <input type="radio"/> No <input checked="" type="radio"/>

Repair Order# 54321 Repair order opening date 16.11.2023 Mileage In Km M 25200

Mobility services provided
Yes No [Select options](#)

Fleet Vehicle
Yes No

Vehicle towed in due to technical issues
Yes No

Open Customer Case
Yes No

Service Note
Leaking water radiator. Rear taillight damaged

CheckSaveBulletinsKnowledge on Line

WW1211:Attention: select the provided mobility services

Warning

WW0370:No Open Campaigns for this vehicle
One or more Privacy consents are missing. Please present our Policy to the customer and request consents.

打开保养条目

已登记保养条目

输入并保存维修单数据后，一个新的状态为“已打开 - 维修进行中”的保养条目将在系统中登记，“故障天数”计数器将开始计算车辆的故障天数。

1. Vehicle Entry 2. Repair 3. Close

Vehicle Entry

Service Entry #	Opening date	Last Update	Days down	Vehicle Downtime	Previous Repair#
IT0098595	16.11.2023	16.11.2023 - WBTESTHQ2	1	1	2

Service Entry Status: Open Repair in Progress

Dealer: 052222 - ROSSOCORSA S.R.L.

Chassis no.: 327800 Plate #: FV358HT Customer Name: 客户姓名 Actual Owner: Yes No

Repair Order#: 54321 Repair order opening date: 16.11.2023 Mileage In: 25200 Km Vehicle towed in due to technical issues: Yes No

Mobility services provided: Yes No 1 selected

Fleet Vehicle: Yes No

Service Note: Leaking water radiator. Rear taillight damaged

Buttons: Back to list, Check, Save, Vehicle Report, Bulletins, Knowledge on Line

Warning: WW0747:RegularWarranty to be started or RepairDate less than Reg.Wty Start Date
WW0370:No Open Campaigns for this vehicle
One or more Privacy consents are missing. Please present our Policy to the customer and request consents.

Vehicle Information Campaign Warranty BOL Change of Ownership Vehicle Configuration Update Service Entry Maintenance



“故障天数”计数器从“维修单打开日期”开始计数，到“维修单关闭日期”结束计数（绿色：1至5天；红色：6天或以上）



输入作业线

输入作业线

进入“维修”工作表

保养条目处于“已打开”(Open) 状态后, 即可单击“2.维修”(2. Repair) 选项卡, 打开工作表并输入作业详细信息。

1. Vehicle Entry2. Repair3. Close

▼ Repair

Service Entry #	Opening date	Last Update	Days down	Vehicle Downtime	Previous Repair#
IT0098595	16.11.2023	20.11.2023 - WBTESTHQ2	5	1	2

Chassis no.	Plate #	Repair Order#	Repair order opening date	Mileage In
327800	FV358HT	LEVANTE S	54321	16.11.2023
				K 25200

Service Entry Status

O - Open Repair in Progress

First Punch Date

Repair Description

Component

Defect code

Customer Complaint

W/C/I

Warning

WW0370:No Open Campaigns for this vehicle

输入作业线

第一次打卡日期

在保养条目关闭之前，必须填写“第一次打卡日期”(First Punch Date)，否则必须在“维修”工作表中输入至少一个打卡时间（在这种情况下，“第一次打卡日期”将与输入的上班打卡时间一致）；如果没有填写上班打卡时间字段，则必须手动输入第一次打卡日期。

1. Vehicle Entry2. Repair3. Close

▼ Repair

Service Entry #	Opening date	Last Update	Days down	Vehicle Downtime	Previous Repair#
IT0098595	16.11.2023	20.11.2023 - WBTESTHQ2	5	1	2

Chassis no.	Plate #	Repair Order#	Repair order opening date	Mileage In
327800	FV358HT	LEVANTE S	54321	16.11.2023
				K 25200

Service Entry Status: O - Open Repair in Progress

First Punch Date

Repair Description: Component: Defect code:

Customer Complaint: W/C/I: Add

Warning
WW0747:RegularWarranty to be started or RepairDate less than Reg.Wty Start Date
WW0370:No Open Campaigns for this vehicle

Back to listRefreshSaveBulletinsKnowledge on LineSummary

Ref.	Repair Description	Component Code	Description	W/C/I	Activity	Status
	Defect code	Customer Complaint				
Records not found						



如果从车辆进入车间的第二天开始进行干预，则“第一次打卡日期”（“第一次上班打卡时间”）可以与“维修单打开日期”不同。

输入作业线

异常作业线

从“维修说明” (Repair Description) 下拉菜单中选择“异常” (Anomaly) 维修类型。

1. Vehicle Entry 2. Repair 3. Close

▼ Repair

Service Entry #	Opening date	Last Update	Days down	Vehicle Downtime	Previous Repair#
IT0098595	16.11.2023	20.11.2023 - WBTESTHQ2	5	1	2

Chassis no.	Plate #	Repair Order#	Repair order opening date	Mileage In
327800	FV358HT	LEVANTE S	16.11.2023	K 25200

Service Entry Status: - Open Repair in Progress First Punch Date: 20.11.2023 08:30

Repair Description: - Component: Defect code: Add

Customer Complaint: W/C/I: Add

Warning
WW0747:RegularWar Date less than Reg.Wty Start Date
WW0370:No Open Car

01 - Anomaly
02 - Paid maintenance
03 - Campaign
04 - Maintenance Program
05 - Additional Services
07 - Paid Repair

Back to list Refresh Save Bulletins Knowledge on Line Summary

Ref.	Repair Description	Component Code	Description	W/C/I	Activity	Status
	Defect code	Customer Complaint				

Records not found

输入作业线

异常作业线

然后单击放大镜并从弹出框中选择部件代码。

The screenshot displays a software interface for vehicle repair management. At the top, there are three tabs: "1. Vehicle Entry", "2. Repair", and "3. Close". The "Repair" tab is active, showing a table with the following data:

Service Entry #	Opening date	Last Update	Days down
IT0098595	16.11.2023	20.11.2023 - WBTESTHQ2	5

Below the table, there are fields for "Chassis no." (327800), "Plate #", "Repair Order#" (54321), and "Service Entry Status" (O - Open). A "Repair Description" dropdown is set to "01 - Anomaly". A "Component" field is highlighted with a magnifying glass icon. A search popup is open, showing a "Search for" section with fields for "Chassis no." (327800), "Project" (61), "Model", "Function Group", and "Description". Below this is a "Component Code" field and a "Search" button. The popup also displays a list of component codes and descriptions:

Code	Description
000105	CPO INSPECTION
010000	SCHEDULED SERVICE
010011	1ST SERVICE
010012	1ST SERVICE
010021	1ST SERVICE
010031	2ND SERVICE
010032	2ND SERVICE
010041	2ND SERVICE
010051	3RD SERVICE
010052	3RD SERVICE

At the bottom of the popup, there are navigation buttons: "Back to list", "Refresh", "Save", "Bulletins", "Knowledge on Line", and "Summary". A "Warning" section is visible, containing the text: "WW0747:RegularWarranty to be started or RepairDate less than Reg.Wty Start Date" and "WW0370:No Open Campaigns for this vehicle". A table at the bottom of the main window shows "Ref.", "Repair Description", "Component Code", and "Description" columns, with a "Records not found" message.

输入作业线

异常作业线

如果您已经知道故障部件代码，请在“部件代码” (Component Code) 字段中输入代码，然后单击“搜索” (Search) 按钮。

The screenshot displays a software interface for vehicle repair management. At the top, there are two tabs: "2. Repair" and "3. Close". Below the tabs, a table shows repair details:

Opening date	Last Update	Days down
16.11.2023	20.11.2023 - WBTESTHQ2	5
Plate #	Repair Order#	
FV358HT	LEVANTE S	54321

Below the table, there is a "Repair in Progress" section with a dropdown menu set to "01 - Anomaly" and a "Component" field with a search icon. A warning message is visible: "Warranty to be started or RepairDate less than Reg.Wty Start Date campaigns for this vehicle".

The main focus is a search dialog box titled "Search for". It contains the following fields:

- Chassis no.: 327800
- Project: 61
- Model: (empty)
- Function Group: (empty)
- Description: (empty)
- Component Code: 170001 (highlighted with a blue box)

A "Search" button is located below the Component Code field. Below the search dialog is a table of search results:

	Code	Description
<input type="radio"/>	000105	CPO INSPECTION
<input type="radio"/>	010000	SCHEDULED SERVICE
<input type="radio"/>	010011	1ST SERVICE
<input type="radio"/>	010012	1ST SERVICE
<input type="radio"/>	010021	1ST SERVICE
<input type="radio"/>	010031	2ND SERVICE
<input type="radio"/>	010032	2ND SERVICE
<input type="radio"/>	010041	2ND SERVICE
<input type="radio"/>	010051	3RD SERVICE
<input type="radio"/>	010052	3RD SERVICE

At the bottom of the search dialog, there are navigation buttons (back, forward, refresh, etc.) and a "Close" button. The page number "1 / 368" is displayed in the bottom right corner.

输入作业线

异常作业线

如果您不知道部件代码，可以通过“功能组” (Function group) 和部件“描述” (Description) 进行搜索。找到正确的部件代码后，选择相关行，将其导入“保养条目”中。

1. Vehicle Entry 2. Repair 3. Close

Repair

Service Entry #	Opening date	Last Update	Days down
IT0098595	16.11.2023	20.11.2023 - WBTESTHQ2	5

Chassis no.	Plate #	Repair Order#
327800	FV358HT	LEVANTE S 54321

Service Entry Status: O - Open Repair in Progress

Repair Description: 01 - Anomaly Component: 61170001

Customer Complaint: W/C/I

Warning

- WW0747:RegularWarranty to be started or RepairDate less than Reg.Wty Start Date
- WW0370:No Open Campaigns for this vehicle

Buttons: Back to list, Refresh, Save, Bulletins, Knowledge on Line, Summary

Ref.	Repair Description	Component Code	Description
	Defect code	Customer Complaint	

Records not found

Search for

Chassis no. 327800 Project 61 Model

Function Group ENGINE Description Water cooling radiator

Component Code

Search

	Code	Description
<input type="radio"/>	170001	WATER COOLING RADIATOR
<input type="radio"/>	170074	WATER COOLING RADIATOR FIXING CLIP
<input type="radio"/>	170081	WATER COOLING RADIATOR UPPER SEAL
<input type="radio"/>	170082	WATER COOLING RADIATOR LOWER SEAL
<input type="radio"/>	170084	SECONDARY WATER COOLING RADIATOR
<input type="radio"/>	170089	WATER COOLING RADIATOR UPPER SEAL BUTTON
<input type="radio"/>	171289	PIPE FROM SIDE EXCHANGERS PIPES GROUP TO SECONDARY WATER COOLING RADIATOR

Buttons: <=> << >> <=> >> >> Close 1 / 1



始终选择导致问题的故障部件代码，或者尝试与正确代码尽可能近似的代码。

输入作业线

异常作业线

然后，在相关字段中选择正确的“故障代码”。

1. Vehicle Entry2. Repair3. Close

Repair

Service Entry #	Opening date	Last Update	Days down	Vehicle Downtime	Previous Repair#
IT0098595	16.11.2023	20.11.2023 - WBTESTHQ2	5	1	2

Chassis no.	Plate #	Repair Order#	Repair order opening date	Mileage In	
327800	FV358HT	LEVANTE S	54321	16.11.2023	K 25200

Service Entry Status: **O - Open** Repair in Progress

First Punch Date: 16.11.2023 08:30

Repair Description: 01 - Anomaly Component: 61170001 WATER COOLING RADIATC Defect code: [dropdown]

Customer Complaint: [input] W/C/I: [dropdown]

Warning
WW0747:RegularWarranty to be started or RepairDate less than Reg.Wty Start Date
WW0370:No Open Campaigns for this vehicle

Buttons: Back to list Refresh Save Bulletins Knowledge on Line Summary

Defect code dropdown list:

- 006 - FISSURE - PUNCTURE
- 014 - OVERHEATING - BURNT
- 036 - SEIZURE-STIFFNESS
- 055 - OBSTRUCTION - CLOGGING-AIR
- 059 - LEAKS / BAD SEALING**
- 063 - NOT TO SPECIFICATIONS
- 068 - WHISTLING NOISE
- 077 - IRREGULAR OR EARLY WEAR
- 120 - FOREIGN OBJECTS, RESIDUES

Ref.	Repair Description	Component Code	Description	W/C/I	Activity	Status
Defect code		Customer Complaint				
Records not found						

输入作业线

异常作业线

插入客户投诉。

The screenshot displays a software interface for entering repair data. At the top, there are three tabs: "1. Vehicle Entry", "2. Repair", and "3. Close". The "Repair" tab is active, showing a table of repair records. The table has columns for Service Entry #, Opening date, Last Update, Days down, Vehicle Downtime, and Previous Repair#. The first row shows Service Entry # IT0098595, Opening date 16.11.2023, Last Update 20.11.2023 - WBTESTHQ2, Days down 5 (highlighted in green), Vehicle Downtime 1, and Previous Repair# 2. Below the table, there are input fields for Chassis no. (327800), Plate # (FV358HT), Repair Order# (54321), Repair order opening date (16.11.2023), and Mileage In (K 25200). A "Service Entry Status" dropdown is set to "0 - Open" with "Repair in Progress" selected. A "First Punch Date" field shows 16.11.2023 at 08:30. The "Repair Description" is "01 - Anomaly", the "Component" is "61170001", and the "Defect code" is "WATER COOLING RADIATC". A "Customer Complaint" field is empty. An "Add" button is visible. A dialog box is open in the foreground, containing the text "Customer reports presence of water on the garage floor." and "Confirm" and "Close" buttons. At the bottom, there is a table with columns for "Description", "W/C/I", "Activity", and "Status". The "Description" column contains "Customer Complaint" and "Records not found".

Service Entry #	Opening date	Last Update	Days down	Vehicle Downtime	Previous Repair#
IT0098595	16.11.2023	20.11.2023 - WBTESTHQ2	5	1	2

Chassis no.	Plate #	Repair Order#	Repair order opening date	Mileage In
327800	FV358HT	54321	16.11.2023	K 25200

Service Entry Status: 0 - Open (Repair in Progress)

First Punch Date: 16.11.2023 08:30

Repair Description: 01 - Anomaly

Component: 61170001

Defect code: WATER COOLING RADIATC

Customer Complaint: [Empty]

Customer reports presence of water on the garage floor.

Description	W/C/I	Activity	Status
Customer Complaint			
Records not found			

输入作业线

异常作业线

指定客户类型（W/C/I=保修/客户/内部）。

1.
Vehicle Entry

2.
Repair

3.
Close

▼ Repair

Service Entry #	Opening date	Last Update	Days down	Vehicle Downtime	Previous Repair#
IT0098595	16.11.2023	20.11.2023 - WBTESTHQ2	5	1	2

Chassis no.	Plate #	Repair Order#	Repair order opening date	Mileage In
327800	FV358HT	LEVANTE S	16.11.2023	K 25200

Service Entry Status

O - Open Repair in Progress

First Punch Date

16.11.2023 08:30

Repair Description 01 - Anomaly

Customer Complaint Customer reports presence of ...

Component 61170001

W/C/I ▼

WATER COOLING RADIATC

Defect code ▼

Add

Warning

WW0747:RegularWarranty to be started or RepairDate less than

WW0370:No Open Campaigns for this vehicle

Back to list
Refresh
Save
Bulletins
Knowledge on Line
Summary

Ref.	Repair Description	Component Code	Description	W/C/I	Activity	Status
	Defect code		Customer Complaint			

Records not found

输入作业线

异常作业线

插入主要干预数据后，即可单击“添加”(Add)按钮创建作业线并显示在工作表底部。无论保养条目处于“已打开”还是“已关闭”状态（请始终参阅状态栏），都可以创建或删除作业线。您可以通过勾选删除框字段，然后单击“保存”(Save)来删除作业线。

1. Vehicle Entry
2. Repair
3. Close

Repair

Service Entry #	Opening date	Last Update	Days down	Vehicle Downtime	Previous Repair#
IT0098595	16.11.2023	20.11.2023 - WBTESTHQ2	5	1	2
Chassis no.	Plate #	Repair Order#	Repair order opening date	Mileage In	
327800	FV358HT	LEVANTE S	54321	16.11.2023	K 25200

Service Entry Status
First Punch Date

O - Open
Repair in Progress
16.11.2023
08.30

Repair Description -
Component []
Defect code []

Customer Complaint []
W/C/I []

Add

Warning

WW0747:RegularWarranty to be started or RepairDate less than Reg.Wty Start Date
WW0370:No Open Campaigns for this vehicle

Back to list
Refresh
Save
Bulletins
Knowledge on Line
Summary

Ref.	Repair Description	Component Code	Description	W/C/I	Activity	Status
	Defect code	Customer Complaint				
1	Anomaly	170001	WATER COOLING RADIATOR	Customer	Repair 1	<input type="checkbox"/>
59	LEAKS / BAD SEALING	Customer reports presence of water				



必须为每个异常/干预创建作业线，如有必要，还必须为其创建保修索赔！
请勿在同一作业线/索赔中输入与不同干预有关的操作和/或备件代码

输入作业线

付费保养作业线

在“维修说明” (Repair Description) 中选择“付费保养” (Paid Maintenance), 然后选择要执行的服务。客户类型已设置为“客户” (Customer)。单击“添加” (Add), 即可为付费保养生成作业线。

1. Vehicle Entry2. Repair3. Close

▼ Repair

Service Entry #	Opening date	Last Update	Days down	Vehicle Downtime	Previous Repair#
IT0098595	16.11.2023	23.11.2023 - WBTESTHQ2	8	1	2

Chassis no.	Plate #	Repair Order#	Repair order opening date	Mileage In
327800	FV358HT	LEVANTE S	16.11.2023	K 25200

Service Entry Status: 0 - Open Repair in Progress

First Punch Date: 16.11.2023 08.30

Repair Description: 02 - Paid maintenance Component: 81010011 1ST SERVICE Defect code: 001 - UPDATING

Customer Complaint: maintenance W/C/I: Customer Add

Warning
WW0747:RegularWarranty to be started or RepairDate less than Reg.Wty Start Date
WW0370:No Open Campaigns for this vehicle

Back to listRefreshSaveBulletinsKnowledge on LineSummary

输入作业线

活动作业线

在“维修说明”(Repair Description) 中选择“活动”(Campaign)。然后，通过“部件”(Component) 下拉菜单选择活动：车辆上所有待执行活动都会列出，带有相关成本代码和部件代码。

1. Vehicle Entry2. Repair3. Close

▼ Repair

Service Entry #	Opening date	Last Update	Days down	Vehicle Downtime	Previous Repair#
IT0098595	16.11.2023	23.11.2023 - WBTESTHQ2	8	1	2

Chassis no.	Plate #	Repair Order#	Repair order opening date	Mileage In	
327800	FV358HT	LEVANTE S	54321	16.11.2023	K 25200

Service Entry Status: O - Open Repair in Progress

First Punch Date: 16.11.2023 08:30

Repair Description: 03 - Campaign Component: 215 - 23 - 57430102 - COMPLETE HANDBRAKE E
265 - 23 - 57190001 - PROGRAMMED IGNITION
270 - 23 - 57020004 - COOLING FLUID Add

Customer Complaint: [] WIC/ []

Warning
WW0747:RegularWarranty to be started or RepairDate less than Reg.Wty Start Date
WW0370:No Open Campaigns for this vehicle

Back to list Refresh Save Bulletins Knowledge on Line Summary



如果尚未参加阻止活动，则无法发送任何索赔以期受理。有关更多详细信息，请参阅本手册的“管理保养条目阻止警告”部分

输入作业线

活动作业线

客户类型已设置为“保修”(Warranty)。选择正确的故障代码后，单击“添加”(Add)生成作业线。

1. Vehicle Entry2. Repair3. Close

▼ Repair

Service Entry #	Opening date	Last Update	Days down	Vehicle Downtime	Previous Repair#
IT0098595	16.11.2023	23.11.2023 - WBTESTHQ2	8	1	2

Chassis no.	Plate #	Repair Order#	Repair order opening date	Mileage In
327800	FV358HT	LEVANTE S	16.11.2023	K 25200

Service Entry Status: Open Repair in Progress

First Punch Date: 16.11.2023 08.30

Repair Description: 03 - Campaign
Component: 215 - 23 - 57430
Defect code: 083 - NOT TO SPECIFICAT

Customer Complaint: Campaign 215
W/C/I: Warranty

Warning
WW0747:RegularWarranty to be started or RepairDate less than Reg.Wty Start Date
WW0370:No Open Campaigns for this vehicle

输入作业线

保养计划作业线

如果车辆必须进行保养干预，并且底盘保养计划定期激活，则可在“维修说明” (Repair Description) 下拉菜单中选择“保养计划” (Maintenance Program)。选择该项目后，将出现新的“保养计划” (Maintenance Program) 按钮。

1.
Vehicle Entry

2.
Repair

3.
Close

▼ Repair

Service Entry #	Opening date	Last Update	Days down	Vehicle Downtime	Previous Repair#
IT0098595	16.11.2023	23.11.2023 - WBTESTHQ2	8	1	2

Chassis no.	Plate #	Repair Order#	Repair order opening date	Mileage In
327800	FV358HT	LEVANTE S	16.11.2023	K 25200

Service Entry Status

O - Open Repair in Progress

First Punch Date

16.11.2023 08.30

Repair Description 04 - Maintenance Program Maintenance Program

Warning

WW0747:RegularWarranty to be started or RepairDate less than Reg.Wty Start Date

WW0370:No Open Campaigns for this vehicle

Back to list Refresh Save Bulletins Knowledge on Line Summary

输入作业线

保养计划作业线

单击“保养计划” (Maintenance Program) 按钮，将出现通常的车辆保养服务列表，可在其中选择服务并单击“执行” (Execute) 选项卡进行登记。保存表格后，将生成一个新的作业线。

The screenshot displays the 'Repair' section of the vehicle maintenance system. It includes a 'Service Entry #' table, a 'Chassis no.' field, a 'Plate #' field, and a 'Service Entry Status' dropdown. A 'Maintenance Program' button is visible, along with a warning message: 'Warning WW0747: Regular Warranty to be started or Repair Date less than Reg. Wty' and 'WW0370: No Open Campaigns for this vehicle'. At the bottom, there are buttons for 'Back to list', 'Refresh', 'Save', 'Bulletins', and 'Knowledge on Line'.

The detailed view of the 'Maintenance Program' shows the following information:

Group	Activity	Check Km	Check Mts	Dealer refund	Refund Importer	Status
100	GDE2KL COUPON 20000 KM	20000	12420			to execute
100	GDE2AL COUPON 12 MONTHS					to execute
200	GDE4KL COUPON 40000 KM	40000	24854			to execute
200	GDE4AL COUPON 24 MONTHS					to execute
300	GDE6KL COUPON 60000 KM	60000	37282			to execute
300	GDE6AL COUPON 36 MONTHS					to execute
	EPDFBD EXTRA PARTS FRONT BRAKE DISKS					to execute
	EPDRBD EXTRA PARTS REAR BRAKE DISKS					to execute
	EPDFBP EXTRA PARTS FRONT BRAKE PADS KIT					to execute
	EPDRBP EXTRA PARTS REAR BRAKE PADS KIT					to execute

输入作业线

额外服务作业线

如果需要与替代交通工具相关的附加服务，您必须在“维修说明” (Repair Description) 下拉菜单中选择“额外服务” (Additional Services)。部件代码已设置为“替代交通工具” (Alternative transportation)。

填写其他字段并单击“添加” (Add)，生成额外服务作业线。

The screenshot displays a software interface for entering repair data. At the top, there are three tabs: "1. Vehicle Entry", "2. Repair", and "3. Close". The "Repair" tab is active, showing a "Repair" section with a table of repair entries. The table has columns for Service Entry #, Opening date, Last Update, Days down, Vehicle Downtime, and Previous Repair#. The first row shows Service Entry # IT0098595, Opening date 16.11.2023, Last Update 23.11.2023 - WBTESTHQ2, Days down 3 (highlighted in red), Vehicle Downtime 1, and Previous Repair# 2. Below the table, there are fields for Chassis no. (327800), Plate # (FV358HT), Repair Order# (54321), Repair order opening date (16.11.2023), and Mileage In (K 25200). There is also a "Service Entry Status" dropdown set to "O - Open" and a "Repair in Progress" checkbox. The "Repair Description" dropdown is set to "05 - Additional Services", and the "Component" field contains "81000100". The "Defect code" dropdown is open, showing options: "301 - LOANER CAR 1 DAY", "500 - ACCIDENT", and "504 - BREAKDOWN". The "Customer Complaint" field contains "breakdown" and the "W/C/I" dropdown is set to "Warranty". An "Add" button is visible next to the defect code dropdown. At the bottom, there is a "Warning" banner with the text "WW0747:RegularWarranty to be started or RepairDate less than Reg.Wty Start Date Campaign to be performed". Navigation buttons at the bottom include "Back to list", "Refresh", "Save", "Bulletins", "Knowledge on Line", and "Summary".

Service Entry #	Opening date	Last Update	Days down	Vehicle Downtime	Previous Repair#
IT0098595	16.11.2023	23.11.2023 - WBTESTHQ2	3	1	2

Chassis no. 327800 Plate # FV358HT Repair Order# 54321 Repair order opening date 16.11.2023 Mileage In K 25200

Service Entry Status: O - Open Repair in Progress

Repair Description: 05 - Additional Services Component: 81000100 Defect code: 504 - BREAKDOWN

Customer Complaint: breakdown W/C/I: Warranty

Warning: WW0747:RegularWarranty to be started or RepairDate less than Reg.Wty Start Date Campaign to be performed

输入作业线

付费维修作业线

如果发生付费维修，请在“维修说明” (Repair Description) 下拉菜单中选择“付费维修” (Paid Repair)。在相关字段中选择部件和故障代码，然后添加客户投诉。客户类型已设置为“客户” (Customer)。填写完所有要求的字段后，单击“添加” (Add)，生成一个客户付费维修作业线。

1. Vehicle Entry2. Repair3. Close

▼ Repair

Service Entry #	Opening date	Last Update	Days down	Vehicle Downtime	Previous Repair#
IT0098595	16.11.2023	23.11.2023 - WBTESTHQ2	3	1	2

Chassis no.	Plate #	Repair Order#	Repair order opening date	Mileage In
327800	FV358HT	LEVANTE S	54321	16.11.2023

Service Entry Status: Open Repair in Progress

First Punch Date: 16.11.2023 08:30

Repair Description: 07 - Paid Repair Component: 81902057 COMPLETE RH TAIL LIGH Defect code: 118 - DAMAGED INTERNAL

Customer Complaint: Rear taillight damaged W/C/I: Customer

Warning
WW0747:RegularWarranty to be started or RepairDate less than Reg.Wty Start Date Campaign to be performed

输入作业线

填写维修信息

要输入有关作业的其他信息，请单击“维修（1、2、3...）” (Repair (1,2,3,...)) 链接。

1. Vehicle Entry2. Repair3. Close

▼ Repair

Service Entry #	Opening date	Last Update	Days down	Vehicle Downtime	Previous Repair#
IT0098595	16.11.2023	20.11.2023 - WBTESTHQ2	5	1	2

Chassis no.	Plate #	Repair Order#	Repair order opening date	Mileage In	
327800	FV358HT	LEVANTE S	54321	16.11.2023	K 25200

Service Entry Status: ○ - Open Repair in Progress

First Punch Date: 16.11.2023 08.30

Repair Description: - Component: [] Defect code: []

Customer Complaint: [] W/C/I: [] Add

Warning
WW0747:RegularWarranty to be started or RepairDate less than Reg.Wty Start Date
WW0370:No Open Campaigns for this vehicle

Back to list Refresh Save Bulletins Knowledge on Line Summary

Ref.	Repair Description	Component Code	Description	W/C/I	Activity	Status
	Defect code	Customer Complaint				
1	Anomaly	170001	WATER COOLING RADIATOR	Customer	Repair 1	
59	LEAKS / BAD SEALING	Customer reports presence of water				

输入作业线

填写维修信息

单击“维修（1、2、3...）” (Repair (# 1,2,3,...)) 后，将出现一个多工作表窗口。第一个“信息” (INFO) 工作表显示：打开保养条目和 BOL 请求（如适用）的用户的数据，以及第一次和最后一次打卡日期（在其输入之后）。

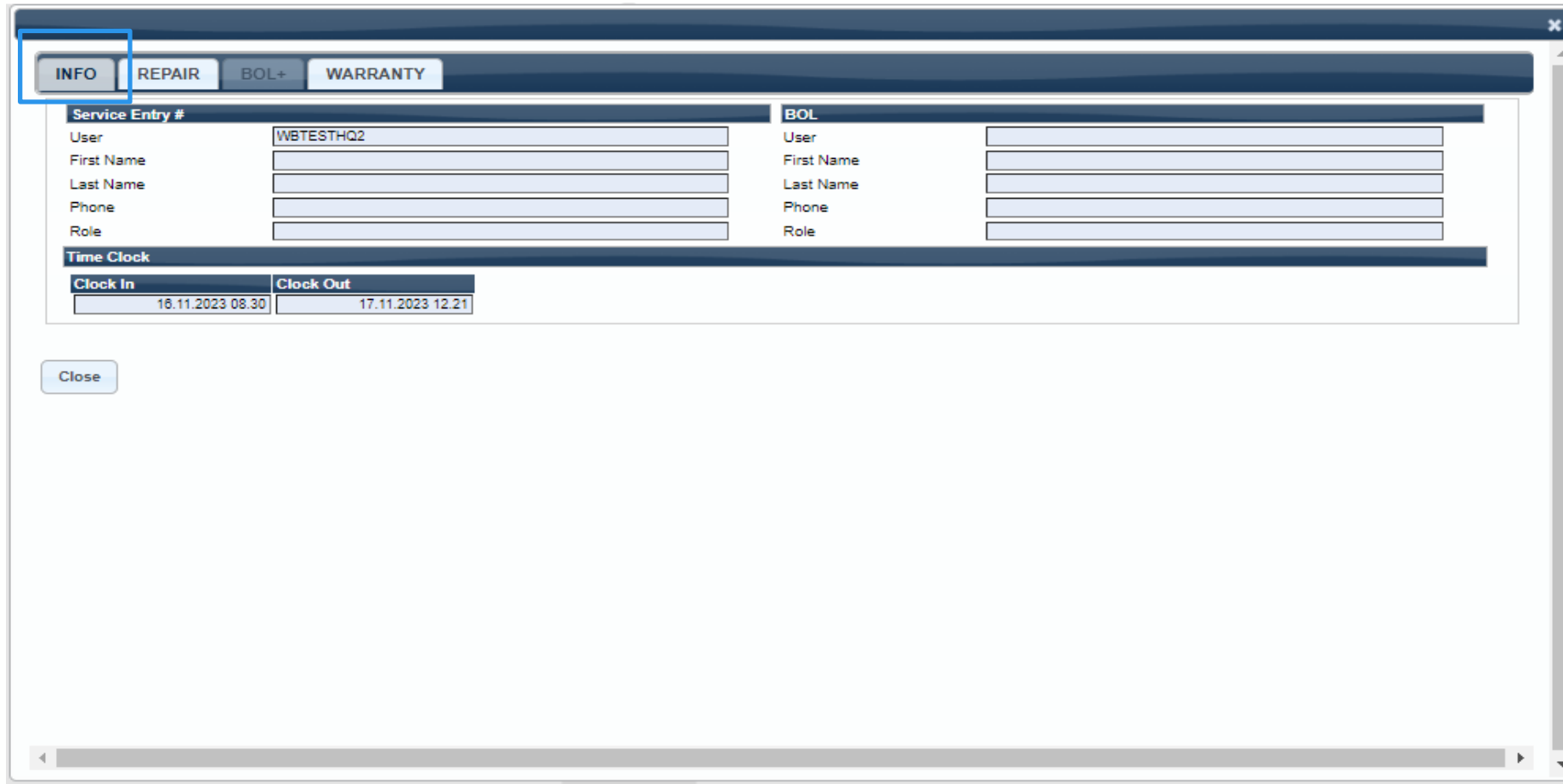

The screenshot shows a software window with a dark blue header and a light blue background. The header contains four tabs: "INFO", "REPAIR", "BOL+", and "WARRANTY". The "INFO" tab is selected and highlighted with a blue box. Below the tabs, there are two main sections: "Service Entry #" and "BOL".

Service Entry #		BOL	
User	WBTESTHQ2	User	
First Name		First Name	
Last Name		Last Name	
Phone		Phone	
Role		Role	

Below the "BOL" section is a "Time Clock" section with a table:

Clock In	Clock Out
16.11.2023 09:30	17.11.2023 12:21

At the bottom left of the window, there is a "Close" button.



BOL 请求只能由经过认证或正在进行认证的技术人员打开。

输入作业线

填写维修信息

在第二个“维修”工作表中，您必须输入其他工作信息：打卡详细信息、工时代码、任何规定工时以及所有已更换备件的代码和数量。单击“保存” (Save)，登记数据。

The screenshot displays a software interface for entering repair information. The 'REPAIR' tab is selected. The interface is divided into three main sections:

- Time Clock [2 Element inserted]:** A table with columns for 'Clock In' and 'Clock Out'. It contains two entries:

Clock In	Clock Out	
16.11.2023 08.30	16.11.2023 09.20	<input type="checkbox"/>
17.11.2023 09.30	17.11.2023 12.21	<input type="checkbox"/>
- Labour Code [1 Element inserted]:** A table with columns for 'Code', 'Description', 'Hours', and 'Amount'. It contains one entry:

Code	Description	Hours	Amount
1700013	WATER COOLING RADIATOR Straight time		2,85 230,850 <input type="checkbox"/>
- Spare Part Replaced [1 Element inserted]:** A table with columns for 'Code', 'Description', 'Quantity', and 'Amount'. It contains one entry:

Code	Description	Quantity	Amount
670030844	WATER RADIATOR	1	412,90 <input type="checkbox"/>

At the bottom of the interface, there are buttons for 'Check', 'Save', 'Upload', 'Close', and a 'Knowledge on Line' button.



在“打卡时间” (Time Clock) 部分中，始终输入维修单中报告的每个上班打卡时间和下班打卡时间！ 如果干预中断，请勿只输入一个累计时间段

输入作业线

填写维修信息

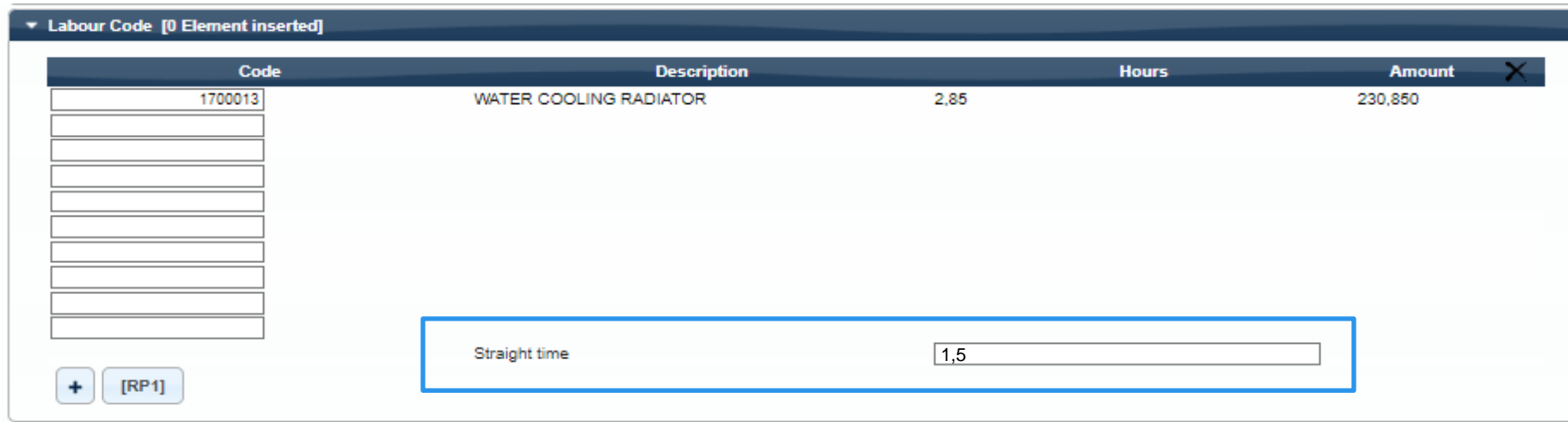

Code	Description	Hours	Amount
1700013	WATER COOLING RADIATOR	2,85	230,850

Straight time

+ [RP1]



如果索赔涉及诊断时间或规定工时，则必须在索赔“注释”部分说明诊断时间或规定工时的必要性。测试结果和所有测量结果必须记录在维修单中，并附在相关索赔中。

每次事故的规定工时必须单独计时。

如果诊断所需时间超过 2 小时，则必须提交一份支持请求 BOL 报告（作为美洲市场的授权请求）。

输入作业线

填写维修信息

要查找正确的工时代码和零件编号，请单击“在线知识” (Knowledge on Line) 按钮。如果要进行保修索赔，可以从“统一费率指南” (Flat Rate Guide) 和“备件目录” (Spare Parts Catalogue) 中导入代码，然后按照下文以及通函 MAS003310 “从‘在线知识’中导入零件编号和操作代码的新程序”中所示的程序进行操作。

The screenshot shows a software interface for entering repair information. It features a top navigation bar with tabs: INFO, REPAIR, BOL+, and WARRANTY. Below this, there are three main sections, each with a dropdown arrow and a count of elements inserted:

- Time Clock [2 Element inserted]**: Contains a table with columns for Clock In (Date and Time) and Clock Out (Date and Time).

Clock In		Clock Out		
16.11.2023	08.30	16.11.2023	09.20	<input type="checkbox"/>
17.11.2023	09.30	17.11.2023	12.21	<input type="checkbox"/>
- Labour Code [1 Element inserted]**: Contains a table with columns for Code, Description, Hours, and Amount.

Code	Description	Hours	Amount	
1700013	WATER COOLING RADIATOR Straight time		2.85 230,850	<input type="checkbox"/>
- Spare Part Replaced [1 Element inserted]**: Contains a table with columns for Code, Description, Quantity, and Amount.

Code	Description	Quantity	Amount	
670030844	WATER RADIATOR	1	412.90	<input type="checkbox"/>

At the bottom of the interface, there are several buttons: Check, Save, Upload, Knowledge on Line (highlighted with a blue box), and Close.

输入作业线

填写维修信息

登录“在线知识”(Knowledge on Line)后,进入“统一费率指南”(Flat Rate Guide)部分,单击相应小车符号即可选择操作代码。

The screenshot displays the Maserati Knowledge on Line interface. On the left, a sidebar shows a car image and technical specifications for a Maserati Levante. The main area features a detailed technical diagram of an engine with numbered parts (1-40). Below the diagram is a table of service codes. A blue box highlights the 'Service Type' column, which includes icons for selecting operation codes.

Pos	Faulty component	Time	Description of faulty component	Service Type Code	Service Type
0	1.00.003.2	12.35	ENGINE	02	Removal and refitting COMPLETE CAR
0	1.00.003.6	13.05	ENGINE	08	Car bench support preparation COMPLETE CAR
0	1.00.003.C	16.35	ENGINE	15	Replacement COMPLETE CAR
0	1.00.123.0	24.40	DIESEL LONG-BLOCK	15	Replacement COMPLETE CAR

输入作业线

填写维修信息

在“备件目录” (Spare Parts Catalogue) 部分，您可以通过单击相应小车符号选择一个或多个备件编号（如适用）。

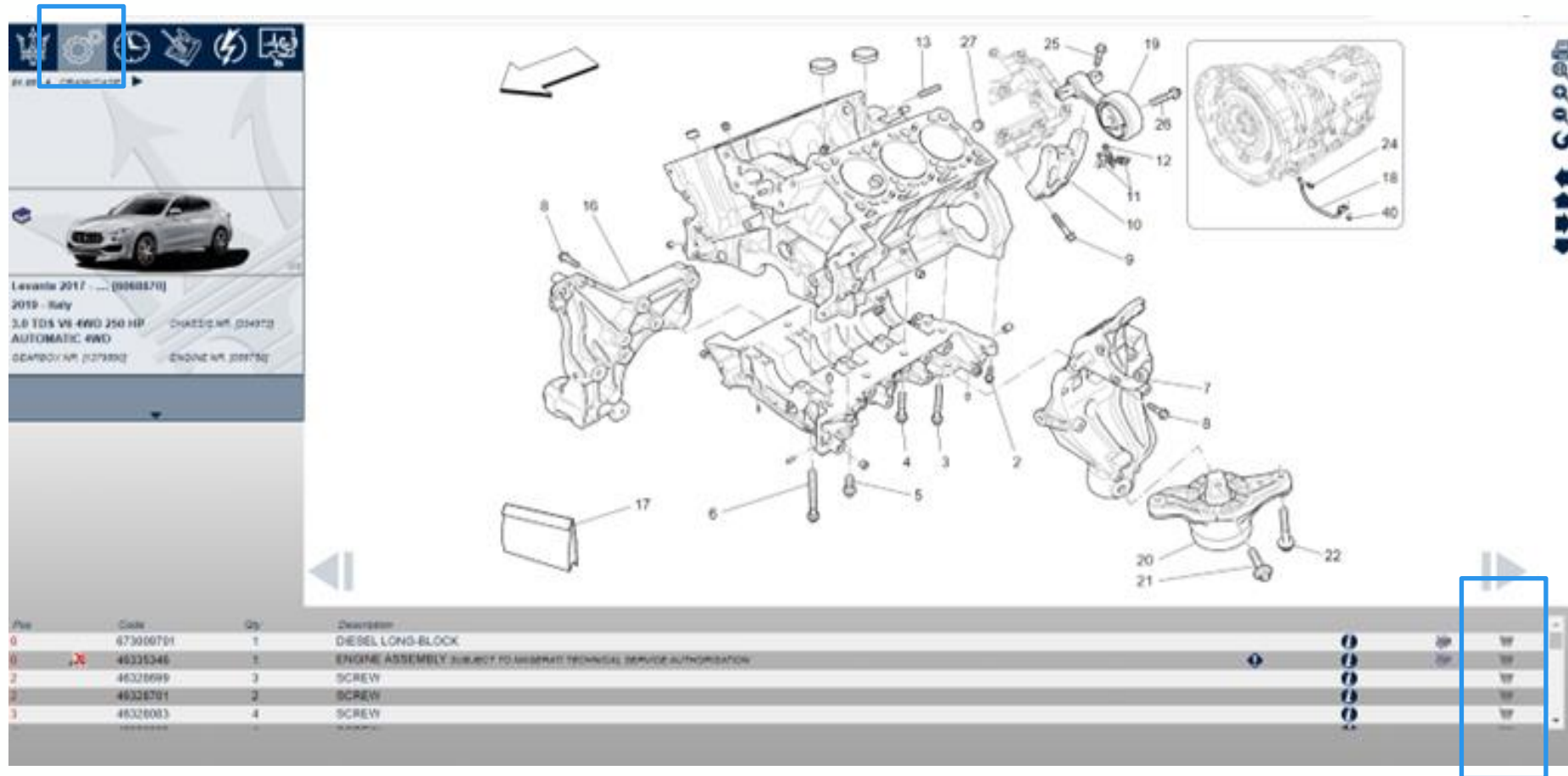

输入作业线

填写维修信息

要查看所有选定代码，您需要单击可访问左下角弹出菜单的箭头来访问“干预列表” (Intervention List) 部分。

The screenshot displays a diagnostic software interface for a Maserati Levante. On the left, a sidebar menu lists various options, with 'INTERVENTION LIST' highlighted in blue. The main area shows a detailed exploded view of an engine assembly with numbered parts (1-27). A callout window on the right shows a close-up of a component with parts 18, 24, and 40. At the bottom, a table lists parts for 'DIESEL LONG-BLOCK'.

Part No.	QTY	Description
1	1	SCREW
2	2	SCREW
3	4	SCREW

输入作业线

填写维修信息

除了在“备件目录” (Spare Parts Catalogue) 和“统一费率指南” (Flat Rate Guide) 中选择的代码外，“干预列表” (Intervention List) 部分有一个“发送索赔” (Send to claim) 按钮，可将这些代码导入保养条目。

Warning: if the ordered part number is replaced, the order is automatically updated with the replacing part number, which in turn will refer to the relevant price list.

Code	Description	V.I.N.	Remarks	Time	Qty	Total Time
670038854	ENGINE ASSEMBLY SUBJECT TO MASERATI TECHNICAL SERVICE AUTHORIZATION	ZAM57XSA1J1290885			1	
1 00 003 7	ENGINE Replacement	ZAM57XSA1J1290885		h 14 10	1	h 14 10

Buttons: Clear, Save, Send to claim



“发送索赔”按钮仅在存在保修索赔时才会激活

输入作业线

填写维修信息

如果所选备件和操作代码的关联存在不一致（例如，未提供与某一操作代码相关的备件），代码将以黄色突出显示。

Warning: if the ordered part number is replaced, the order is automatically updated with the replacing part number, which in turn will refer to the relevant price list.

Code	Description	V.I.N.	Qty
870038854	ENGINE ASSEMBLY SUBJECT TO MASERATI TECHNICAL SERVICE AUTHORIZATION	ZAM57XSA1J1290885	1

01.00 / 2 (0)

Code	Description	V.I.N.	Remarks	Time	Qty	Total Time
1.00.003.0	ENGINE Removal and refitting	ZAM57XSA1J1290885		h 12 10	1	h 12 10

Clear Save Send to claim

QINb6i 2017 - ... [5064402]
2018 - USA
3.0 BT SOFT V8 2WD 350 CHASSIS NR [20682]
HP AUTOMATIC GEARBOX NR [0567463] ENGINE NR [0489784]

INTERVENTIONS LIST

输入作业线

填写维修信息

单击问号后，将显示不一致的原因。

Warning: if the ordered part number is replaced, the order is automatically updated with the replacing part number, which in turn will refer to the relevant price list.

Code	Description	VIA	Qty
870038854	ENGINE ASSEMBLY SUBJECT TO MASERATI TECHNICAL SERVICE AUTHORIZATION	ZAM57XSA1J1290885	1

01.00 / 2 (0)

Code	Description	VIA	Remarks	Time	Qty	Total Time
1.00.003.0	ENGINE Removal and refitting	ZAM57XSA1J1290885		h 12.10	1	h 12.10

Attention: this type of labour code doesn't allow the insertion of spare parts

Clear Save Send to claim

输入作业线

填写维修信息

在继续查询索赔之前，如果您尚未完成“在线知识”平台上的所有操作，则会有提示消息提醒您。

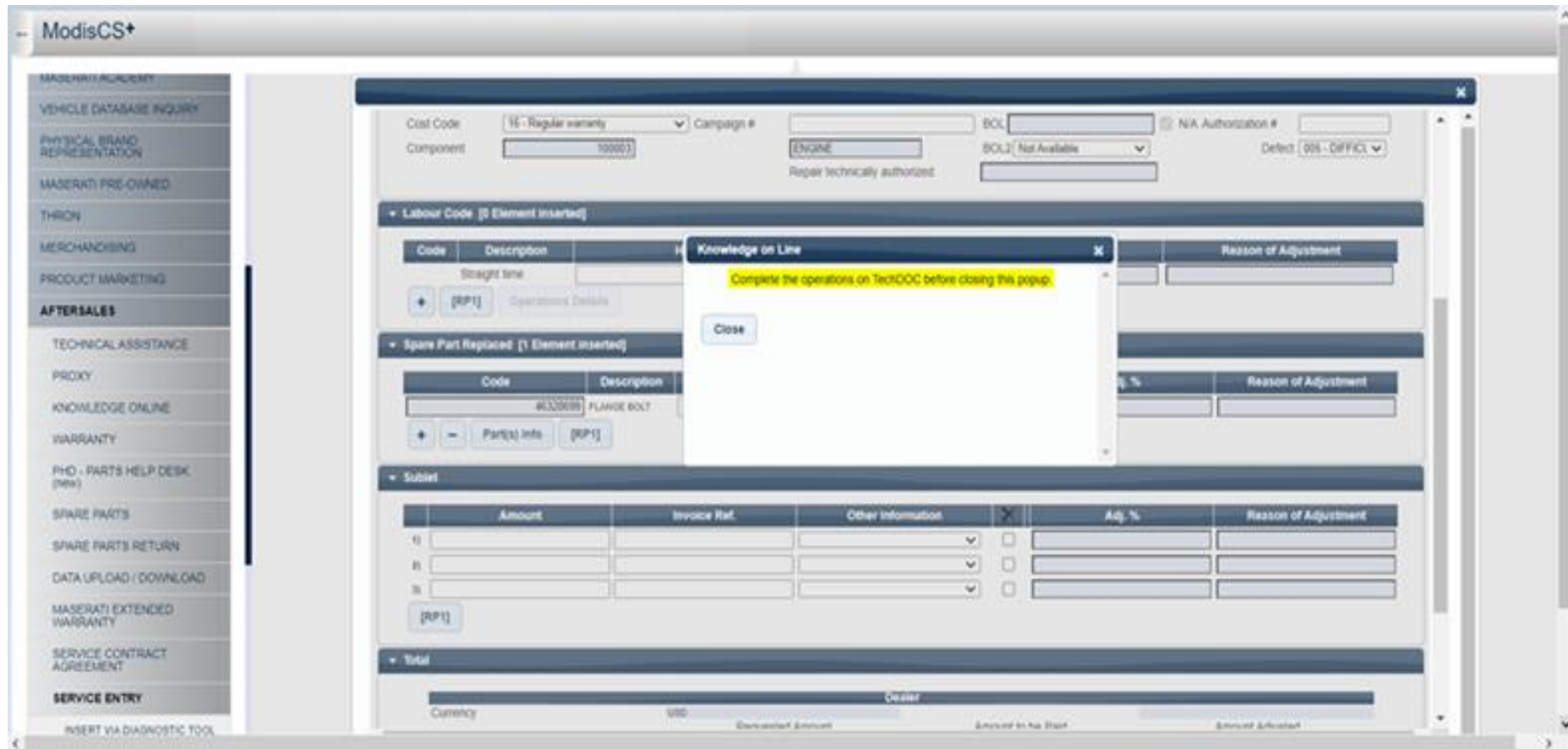

输入作业线

填写维修信息

您也可以通过保养条目“车辆条目”工作表中的按钮访问“在线知识”门户网站。

1. Vehicle Entry2. Repair3. Close

Vehicle Entry

Service Entry #	Opening date	Last Update	Days down	Vehicle Downtime	Previous Repair#
IT0098595	16.11.2023	21.11.2023 - WBTESTHQ2	8	1	2

Dealer

Chassis no.	Plate #	Customer Name	Actual Owner
<input type="text" value="327800"/>	<input type="text" value="FV358HT"/>	<input type="text" value="LEVANTE S"/>	<input type="text" value="客户姓名"/> Yes <input type="radio"/> No <input checked="" type="radio"/>

Repair Order#	Repair order opening date	Mileage In	Vehicle towed in due to technical issues	Loaner Car
<input type="text" value="54321"/>	<input type="text" value="16.11.2023"/>	Km <input checked="" type="radio"/> M <input type="radio"/> <input type="text" value="25200"/>	Yes <input type="radio"/> No <input checked="" type="radio"/>	Yes <input type="radio"/> No <input checked="" type="radio"/>

Mobility services provided
Yes No

Fleet Vehicle
Yes No

Service Note

输入作业线

填写维修信息

或者，您可以通过“在线知识”(Knowledge on Line)\“在线技术文档”(Technical Documentation Online) 菜单直接访问“统一费率指南”(Flat Rate Guide) 和“备件目录”(Spare Parts Catalogue)。



The 'Vehicle Entry' form contains the following fields and controls:

- Buttons: 1. Vehicle Entry, 2. Repair, 3. Close
- Section: Vehicle Entry
- Table:

Service Entry #	Opening date	Last Update
IT0098595	18.11.2023	21.11.2023 - WBTESTHQ2
- Buttons: Service Entry Status, Status Changes
- Form: O - Open, Repair in Progress
- Field: Dealer (052222 - ROSSOCORSA S.R.L.)
- Table:

Chassis no.	Plate #	
327800	FV358HT	LEVANTE S
- Table:

Repair Order#	Repair order opening date	Mileage In
54321	18.11.2023	Km <input checked="" type="radio"/> M <input type="radio"/> 25200
- Form: Mobility services provided (Yes No)
- Form: Fleet Vehicle (Yes No)
- Form: Service Note (Leaking water radiator. Rear taillight damaged)
- Buttons: Back to list, Check, Save, Vehicle Report, Bulletins, Knowledge on Line
- Warning bar: Warning



输入 BOL 请求

输入 BOL 请求

进入“BOL+”工作表

单击维修的“BOL+”按钮，进入相关工作表，填写或查询 BOL 请求。

The screenshot displays a software window with a dark blue header bar containing four tabs: INFO, REPAIR, BOL+, and WARRANTY. The BOL+ tab is highlighted with a blue box. Below the tabs, the interface is divided into two main sections. The left section is titled 'Service Entry #' and contains a table with the following data:

Service Entry #	Value
User	WBTESTHQ2
First Name	
Last Name	
Phone	
Role	

The right section is titled 'BOL' and contains a table with the following data:

BOL	Value
User	
First Name	
Last Name	
Phone	
Role	

Below these sections is a 'Time Clock' section with a table showing clock in and out times:

Clock In	Clock Out
16.11.2023 08.30	17.11.2023 12.21

A 'Close' button is located at the bottom left of the window.

输入 BOL 请求

填写“BOL+”工作表

在“BOL+”工作表中，您必须在打开请求之前填写所有必填字段。如果您需要诊断帮助，请单击“诊断”(Diagnosis)按钮，查询可用诊断工作表。

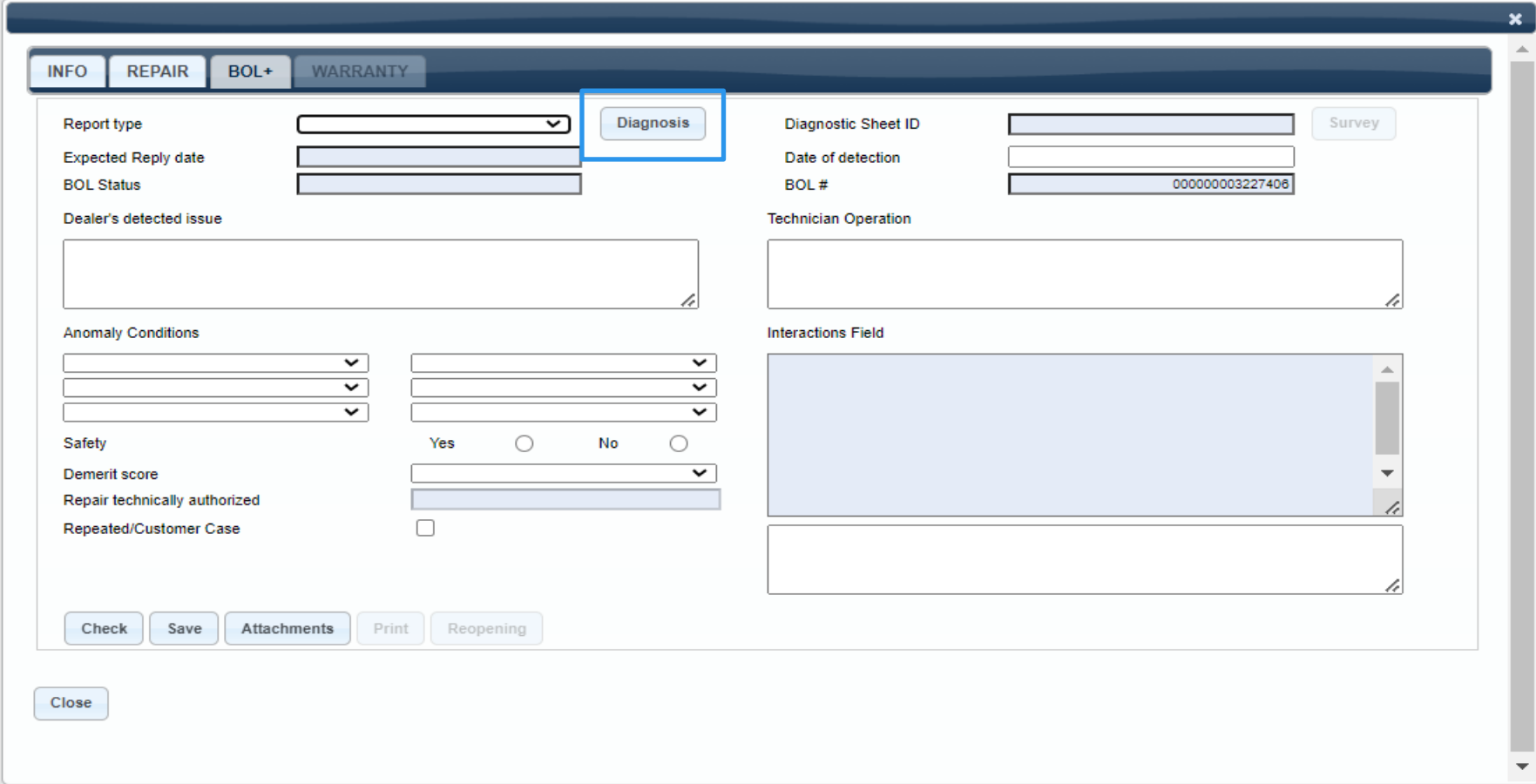

The screenshot shows a web-based form for entering a BOL+ request. The form is divided into several sections:

- Navigation:** Tabs for INFO, REPAIR, BOL+, and WARRANTY. The BOL+ tab is active.
- Report Information:** Fields for Report type (dropdown), Expected Reply date, and BOL Status.
- Diagnosis Section:** A blue box highlights the "Diagnosis" button. To its right is a "Survey" button.
- Diagnostic Data:** Fields for Diagnostic Sheet ID, Date of detection, and BOL # (containing the value 00000003227406).
- Dealer's detected issue:** A large text area for describing the problem.
- Technician Operation:** A large text area for recording the technician's actions.
- Anomaly Conditions:** Three dropdown menus for selecting specific conditions.
- Safety:** Radio buttons for "Yes" and "No".
- Demerit score:** A dropdown menu.
- Repair technically authorized:** A dropdown menu.
- Repeated/Customer Case:** A checkbox.
- Buttons:** Check, Save, Attachments, Print, Reopening, and Close.

输入 BOL 请求

“诊断”工作表查询

找到所需诊断工作表后，单击“应用”(Apply)，打开所选诊断的 BOL 请求。单击“书籍”图标，您可以查阅 pdf 格式的表格。

The screenshot shows a software interface with a table of diagnostic sheets. The table has columns for Diagnostic Sheet ID, File name, Size, Sent on, and View. The 'Apply' button is highlighted with a blue box. Below the table, there is a list of files with columns for Progressive, File name, Size, Sent on, and View. The 'View' icon for the first file is highlighted with a blue box.

Diagnostic Sheet ID	File name	Size	Sent on	View	
DS2011017	000000000000177	P1382 / SCANNER PRESTAZIONE MOTORE (ERRORI P0327-P0328-P1382- P1383)	Engine	ALL MODELS	0
DS2011004	000000000000164	DS: CHECK ENGINE LIGHT ON (ERROR P0016-P0018-P1013- P1015) / SPIA AVARIA MOTORE (ERRORI P0016-P0018-P1013- P1015)	Engine	ALL MODELS	0

Progressive	File name	Size	Sent on	View
0	DS_001-2011_VIBRAZIONE MOTORE (CIRCA 1500 – 1700 rpm).docx	302580	2011-10-06 13:04:10	
1	DS_001- 2011_Engine_Vibration.pdf	342937	2011-10-06 12:51:19	

输入 BOL 请求

BOL 交互

您可以通过可编辑字段与 BOL 服务台进行交互，并在需要使用“附件” (Attachments) 按钮共享文件。

- 只有在以下情况下，才可将先前关闭的 BOL 请求链接到在下一个保养条目中提交的保修索赔：
 - VIN 相同
 - 新保养条目作业线中的部件代码（异常）相同
 - 前一个 BOL 请求关闭日期和新维修单打开日期之间的间隔时间不超过 45 天。

The screenshot shows a web-based form for entering a BOL request. The form is organized into several sections:

- Report Information:** Report type (Support request), Expected Reply date (24.11.2023), BOL Status (Pending info from Dealer).
- Dealer's detected issue:** A text area containing "Knocking noise tuning the steering wheel".
- Diagnostic Information:** Diagnostic Sheet ID, Date of detection, and BOL # (00000003227873).
- Technician Operation:** A text area containing "Visual inspection of steering rack. Early wear of left joint."
- Interactions Field:** A text area containing a message: "22 November 2023 13.50 SAT HD - Good morning, please attach to the BOL picture of damaged joint. Check as well any evidence of external damages on steering rack tie rod and surrounding area. Thanks FG".
- Bottom Section:** Includes buttons for Check, Save, Attachments (highlighted with a blue box), Print, and Reopening. A Close button is located at the bottom left.

输入 BOL 请求

BOL 参考

完成并保存所有 BOL 详细信息后，BOL 关闭通知即会出现在相关作业线和相关索赔中，其中存在一个可链接到维修的“BOL+”工作表的“BOL”按钮。



仅在保养条目处于“已打开”状态（请始终参阅状态栏）时，才可填写或重新打开 BOL；
除非通过服务台请求，否则无法删除 BOL。

Ref.	Repair Description	Component Code	Description	W/C/I	X	Activity	Status	X
Defect code		Customer Complaint						
1	Anomaly	831001	RH REAR TAILLIGHT	Costumer	<input type="checkbox"/>	Repair 1		<input type="checkbox"/>
95 - SCRATCHES, SCORES		scratches on the right rear taillight						
2	Anomaly	170001	WATER COOLING RADIATOR	Warranty	<input type="checkbox"/>	Repair 2	BOL 00000000110008 Closed	<input type="checkbox"/>
83 - NOT TO SPECIFICATIONS		The customer reports the presence of water on t						
3	Anomaly	510001	SERVO-ASSISTED STEERING RACK	Warranty	<input type="checkbox"/>	Repair 3	BOL 00000000110018 Closed	<input type="checkbox"/>
67 - NOISE, KNOCK		Customer reports noise turning the steering whe						

▼ Defect

Cost Code: 16 - Regular warranty Campaign #: [] BOL: 00000000110008 N/A Authorization #: []

Component: 170001 水冷散热器 BOL2: [] Defect: 063

Repair technically authorized: []



提交保修索赔并关闭保养条目

提交保修索赔并关闭保养条目

进入“保修”工作表

单击维修的“保修”(Warranty) 选项卡，进入相关工作表并完成保修索赔

The screenshot shows a software window with a dark blue header and a light blue background. At the top, there is a menu bar with four tabs: 'INFO', 'REPAIR', 'BOL+', and 'WARRANTY'. The 'WARRANTY' tab is highlighted with a blue border. Below the menu bar, there are two columns of input fields. The left column is titled 'Service Entry #' and contains fields for 'User' (with the value 'WBTESTHQ2'), 'First Name', 'Last Name', 'Phone', and 'Role'. The right column is titled 'BOL' and contains fields for 'User', 'First Name', 'Last Name', 'Phone', and 'Role'. Below these fields is a 'Time Clock' section with a table showing 'Clock In' as '16.11.2023 08.30' and 'Clock Out' as '17.11.2023 12.21'. At the bottom left of the window, there is a 'Close' button. The window has a standard Windows-style title bar with a close button (X) in the top right corner and a scrollbar on the right side.

提交保修索赔并关闭保养条目

填写保修索赔

在“保修”工作表中，您必须输入完成索赔所需的信息，如成本代码、工时和备件信息。

INFO REPAIR BOL+ WARRANTY

WW0989: Attention: Warranty in draft state

Repair

Warranty # Dealer Repair Order # Creation claim date
Chassis no. Assembly # Submit date HQ/Importer
Service Entry # Confirmation claim date
Date in Service Warranty Start Date
Mileage Km M In Warranty End Date

Defect

Cost Code Campaign # BOL N/A Authorization #
Component BOL2 Defect
Repair technically authorized

Labour Code [0 Element inserted]

Code	Description	Hours	Amount	Adj. %	Reason of Adjustment
	Straight time	<input type="text"/>	<input type="text"/>	<input type="text"/>	<input type="text"/>

Spare Part Replaced [1 Element inserted]

Code	Description	Quantity	Amount	Part Return Causes	Adj. %	Reason of Adjustment
<input type="text" value="188814"/>	<input type="text" value="OIL FILTER CARTRIDGE"/>	<input type="text" value="25"/>	<input type="text" value="20,57"/>	<input type="text" value="RESI RETE Modena"/>	<input type="text"/>	<input type="text"/>

提交保修索赔并关闭保养条目

填写保修索赔

在下表中，您可以找到主要保修成本代码列表。有关具体市场的其他成本代码，请参考当地政策。

SCOPE	COST CODE	COST CODE NAME	COST CODE DESCRIPTION
Pre-delivery	12	PDI	Pre-delivery repairs
Contractual Warranty	16	Contractual Warranty	Contractual Warranty
Parts Warranty	21	Parts Warranty	Warranty on defective parts and accessories bought by the Customer
Campaigns	23	Service campaigns	Product improvement campaigns
Campaigns	24	Recall campaigns	Product improvement campaigns for safety related components
Extra Warranty Grant	22	Technical goodwill	Contribution for repairs with warranty voided or expired
Extra Warranty Grant	26	Commercial gesture	Commercial gesture
Extra Warranty Grant	28	ABM Goodwill	Contribution on repair approved by ABM
Extra Warranty Grant	29	CRM Goodwill	Contribution on repair approved by Customer Care Department
Loyalty Programs	25	Certified Pre-Owned (CPO)	Warranty devoted to used vehicles
Loyalty Programs	35	Maintenance	Maintenance programs
Loyalty Programs	36	Extended Warranty	Extended Warranty
Extra Warranty Grant	62	Consumer Protection Law	Contribution for trade-in and buy-back
Mobility Services	75	Assistance	Mobility services provided during warranty validity period

提交保修索赔并关闭保养条目

填写保修索赔

如果已在“维修”工作表中输入了工时代码、备件代码和规定工时，则这些数据已存在于“保修”工作表中，因此无需再次输入。

The screenshot shows a software interface for submitting a warranty claim. It consists of several sections:

- Main Data Entry:** A grid of input fields for multiple items. Each row includes a dropdown menu set to "Not required" and a value of "0.00".
- Sublet Section:** A table with columns: Amount, Invoice Ref., Other Information, a checkbox, Adj. %, and Reason of Adjustment. It contains three rows labeled 1), 2), and 3).
- Total Section:** Two summary tables side-by-side.

Dealer				Importer / Branch			
Currency	USD	Exchange Rate	1.000000000	Currency	EUR	Exchange Rate	1.091100000
	Requested Amount	Amount to be Paid	Amount Adjusted		Requested Amount	Amount to be Paid	Amount Adjusted
Labour	0.000	0.000		Labour	0.000	0.000	
Spare Part	0.000	0.000		Spare Part	0.000	0.000	
Sublet	0.000	0.000		Sublet	0.000	0.000	
Total	0.000	0.000		Total	0.000	0.000	
- Buttons:** Check, Save, Print, Upload, Note, Knowledge on Line, Authorization request, Authorization request history.

提交保修索赔并关闭保养条目

填写保修索赔

如果尚未输入工时和部件信息，您也可以单击“在线知识”(Knowledge on Line) 按钮查询并导入正确代码。

The screenshot shows a software interface for submitting a warranty claim. It consists of several sections:

- Main Data Entry:** A table with multiple rows of input fields. Each row contains a numerical value (e.g., 0.00), a dropdown menu (all set to "Not required"), and two empty text boxes. A "+" button and "[RP1]" button are located below this section.
- Sublet Section:** A section titled "Sublet" containing a table with columns: Amount, Invoice Ref., Other Information, a checkbox, Adj. %, and Reason of Adjustment. There are three rows labeled 1), 2), and 3). A "[RP1]" button is located below the table.
- Total Section:** A section titled "Total" containing two summary tables. The first table is for the "Dealer" (Currency: USD, Exchange Rate: 1.000000000) and the second is for the "Importer / Branch" (Currency: EUR, Exchange Rate: 1.091100000). Both tables have columns for Requested Amount, Amount to be Paid, and Amount Adjusted. The rows include Labour, Spare Part, Sublet, and Total.
- Buttons:** A row of buttons at the bottom: Check, Save, Print, Upload, Note, Knowledge on Line (highlighted with a blue box), Authorization request, and Authorization request history.

提交保修索赔并关闭保养条目

填写保修索赔

如果发生外部干预（转租），请在“转租” (Sublet) 索赔部分输入外部维修开具的发票编号、金额（扣除增值税）和维修说明。

外部维修仅在 Maserati 车间无法借助已有标配设备执行维修作业时才被接受。如果外部维修包含在“在线知识”文件中，则赔付金额将与 KoL 中的金额一致。否则，赔付金额应为所执行操作对应的合理金额。发票必须通过“上传” (Upload) 按钮附在索赔中。

▼ Sublet

	Amount	Invoice Ref.	Other Information	X	Adj. %	Reason of Adjustment
1)	500	75193	body repair	<input type="checkbox"/>		
2)				<input type="checkbox"/>		
3)				<input type="checkbox"/>		

[RP1]

▼ Total

Dealer				Importer / Branch			
Currency	EUR	Exchange Rate	1,000000000	Currency	EUR	Exchange Rate	1,000000000
	Requested Amount	Amount to be Paid	Amount Adjusted		Requested Amount	Amount to be Paid	Amount Adjusted
Labour			0,000	Labour			0,000
Spare Part	592,230	592,230	0,000	Spare Part	592,230	592,230	0,000
Sublet			0,000	Sublet			0,000
Total	592,230	592,230	0,000	Total	592,230	592,230	0,000

Check Save Print **Upload** Note Knowledge on Line Authorization request Authorization request history

Close

提交保修索赔并关闭保养条目

填写保修索赔

插入所有索赔详细信息后，单击“保存” (Save) 按钮。

▼ Sublet

	Amount	Invoice Ref.	Other Information	✕	Adj. %	Reason of Adjustment
1)	500	75193	body repair	<input type="checkbox"/>		
2)				<input type="checkbox"/>		
3)				<input type="checkbox"/>		

[RP1]

▼ Total

Dealer				Importer / Branch			
Currency	EUR	Exchange Rate	1,000000000	Currency	EUR	Exchange Rate	1,000000000
	Requested Amount	Amount to be Paid	Amount Adjusted		Requested Amount	Amount to be Paid	Amount Adjusted
Labour			0,000	Labour			0,000
Spare Part	592,230	592,230	0,000	Spare Part	592,230	592,230	0,000
Sublet			0,000	Sublet			0,000
Total	592,230	592,230	0,000	Total	592,230	592,230	0,000

Check Save Print Upload Note Knowledge on Line Authorization request Authorization request history

Close



如果由于存在一条或多条可删除阻止消息而无法保存保修索赔，
请单击“授权请求” (Authorization request) 按钮，按照本手册“管理保养条目阻止警告”部分中所述的程序进行操作。

提交保修索赔并关闭保养条目

索赔处于临时状态

完成并保存索赔后，相关作业线中将出现一个通知。该索赔现在处于“临时”状态。

1. Vehicle Entry
2. Repair
3. Close

▼ Repair

Service Entry #	Opening date	Last Update	Days down	Vehicle Downtime	Previous Repair#
IT0098595	18.11.2023	24.11.2023 - WBTESTHQ2	9	1	2

Chassis no.	Plate #	Repair Order#	Repair order opening date	Mileage In
327800	FV358HT	LEVANTE S	54321	18.11.2023

Service Entry Status

- Open Repair in Progress

First Punch Date

18.11.2023 08.30

Repair Description Component Defect code

Customer Complaint W/C/I Add

Warning

Campaign to be performed

Back to list
Refresh
Save
Bulletins
Knowledge on Line
Summary



只要索赔处于“临时”（尚未发送）状态，即可通过勾选删除框字段，然后单击“保存” (Save) 选项卡将其删除

Ref.	Repair Description	Component Code	Description	W/C/I	Activity	Status
	Defect code	Customer Complaint				
5	Campaign No. 00338	190001	PROGRAMMED IGNITION CONTROL UN	Warranty <input type="text" value=""/>	Repair 5	<input type="checkbox"/>
63	- NOT TO SPECIFICATIONS	campaign			Claim 1 Temporary	

提交保修索赔并关闭保养条目

进入“关闭”工作表

只有在关闭保养条目后才能发送索赔。要关闭保养条目，请打开“3.关闭”(3. Close)工作表。

1.
Vehicle Entry

2.
Repair

3.
Close

▼ Close

Service Entry #	Opening date	Last Update	Days down	Vehicle Downtime	Previous Repair#
IT0098595	16.11.2023	24.11.2023 - WBTESTHQ2	9	1	2

Chassis no.	Plate #	Repair Order#	Repair order opening date	Mileage In
327800	FV358HT	LEVANTE S	54321	16.11.2023 Km 25200

Service Entry Status: O - Open

Repair in Progress

Last Punch Date	Repair order closing date	Mileage Out	Km	M	Issues fixed at first time (FRFT)
			<input checked="" type="radio"/>	<input type="radio"/>	Yes <input type="radio"/> No <input type="radio"/>

Back to listCheckSaveSummaryAuthorization requestAuthorization request history

Warning
Campaign to be performed

▼ Warranty to be sent

<input checked="" type="checkbox"/>	5	Campaign	61190001	PROGRAMMED IGNITION CONTROL UN	Claim 1
<input checked="" type="checkbox"/>	6	Campaign	61941090	PILOT SIDE FRONT SEAT CABLES	Claim 2
<input checked="" type="checkbox"/>	7	Campaign	61871223	MTC+ MODULE WITH DISPLAY	Claim 3
<input checked="" type="checkbox"/>	8	Campaign	61144001	FUEL VAPOUR FILTER	Claim 4

提交保修索赔并关闭保养条目

输入关闭数据

填写“最后一次打卡日期” (Last Punch date)、“维修单关闭日期” (Repair Order Closing date) 和“出站里程” (Mileage out)。

1. Vehicle Entry2. Repair3. Close

▼ Close

Service Entry #	Opening date	Last Update	Days down	Vehicle Downtime	Previous Repair#
IT0098595	16.11.2023	24.11.2023 - WBTESTHQ2	0	1	2

Chassis no.	Plate #	Repair Order#	Repair order opening date	Mileage In
327800	FV358HT	LEVANTE S	16.11.2023	Km 25200

Service Entry Status: - Open

Repair in Progress: - Open

Last Punch Date	Repair order closing date	Mileage Out	Issues fixed at first time (FRFT)
23.11.2023	23.11.2023	25230 Km <input checked="" type="radio"/> M <input type="radio"/>	Yes <input type="radio"/> No <input type="radio"/>

Buttons: Back to list, Check, Save, Summary, Authorization request, Authorization request history

Warning: Campaign to be performed

▼ Warranty to be sent

<input checked="" type="checkbox"/>	5	Campaign	61190001	PROGRAMMED IGNITION CONTROL UN
<input checked="" type="checkbox"/>	6	Campaign	61941090	PILOT SIDE FRONT SEAT CABLES
<input checked="" type="checkbox"/>	7	Campaign	61871223	MTC+ MODULE WITH DISPLAY
<input checked="" type="checkbox"/>	8	Campaign	61144001	FUEL VAPOUR FILTER



如果交付日期和维修结束日期相隔一天，则“最后一次打卡日期”（最后一次下班打卡时间）和“维修单关闭日期”（车辆交付日期）不一致。

“最后一次打卡日期”、“维修单关闭日期”和“出站里程”必须始终与本地 DMS/维修单上登记的详细信息保持一致

提交保修索赔并关闭保养条目

“首次维修即解决问题 (FRFT)” 选择

“首次维修即解决问题 (FRFT)” (Issues fixed at the first time (FRFT)) 选择跟踪车辆第一次进入车间时客户投诉的解决情况。

您必须报告维修是否已完成，可选择“是” (YES) 或“否” (NO)。

如果选择“否”，则必须在下拉菜单中选择以下一个或多个适用选项：

- 无可用备件
- 维修未获客户批准
- 客户要求的车辆交付
- 无可用技术解决方案

The screenshot displays a software interface for managing vehicle repairs. At the top, there are three tabs: "1. Vehicle Entry", "2. Repair", and "3. Close". The "Close" tab is active, showing a form for a repair entry. The form includes several data fields:

Service Entry #	Opening date	Last Update	Days down	Vehicle Downtime	Previous Repair#
IT0098595	16.11.2023	24.11.2023 - WBTESTHQ2	9	1	2

Chassis no.	Plate #	Repair Order#	Repair order opening date	Mileage In
327800	FV358HT	54321	16.11.2023	Km 25200

Below the tables, there are fields for "Service Entry Status" (set to "O - Open"), "Repair in Progress", "Last Punch Date" (23.11.2023), "Repair order closing date" (23.11.2023), and "Mileage Out" (25230). There are also radio buttons for "Km" and "M", and a section for "Issues fixed at first time (FRFT)" with "Yes" and "No" options, where "No" is selected. A dropdown menu titled "Select options" is open, showing four checkboxes: "Spare part/s not available", "Repair not approved by Cust.", "Customer required car delivery", and "Tech. solution not available". At the bottom, there is a "Warning" section with a pink background and the text "Campaign to be performed", and a "Warranty to be sent" section with a table containing a checked checkbox, the number "5", the word "Campaign", the ID "61190001", and the description "PROGRAMMED IGNITION CONTROL UN".

提交保修索赔并关闭保养条目

更新车辆参数

尽管“车辆条目”表中提供了“车辆配置”功能，但在关闭保养条目之前，必须将对车辆配置所做的所有更改通知工厂，无论这些更改是与保修期内的服务相关还是与保修期外的服务相关。

The screenshot shows a web interface for vehicle service entries. At the top, there are three tabs: "1. Vehicle Entry", "2. Repair", and "3. Close". The "Vehicle Entry" tab is active. Below the tabs, there is a form with the following fields:

Service Entry #	Opening date	Last Update	Days down	Vehicle Downtime	Previous Repair#
IT0012574	10.05.2016	25.05.2016 - ITSEPLUS1	18	0	3

Below the table, there are several sections:

- Service Entry Status:** Radio buttons for "Open" (selected) and "Repair in Progress".
- Dealer:** A dropdown menu.
- Chassis no.:** 159884
- Plate #:** EZ208HX
- Mileage in:** 27500 (with radio buttons for Km, M, and another Km).
- Vehicle towed in due to technical issues:** Radio buttons for "Yes" and "No" (selected).
- Actual Owner:** Radio buttons for "Yes" (selected) and "No".
- Repair Order#:** 2487
- Repair order opening date:** 10.05.2016
- Service Note:** A text input field.

At the bottom of the form, there are several buttons: "Back to list", "Check", "Save", "Vehicle Report", "Bulletins", and "Knowledge on Line".

A warning message is displayed in a pink box:

Warning
WW0370:No Open Campaigns for this vehicle
If the flag "actual owner" was incorrectly selected,please contact your ABM

Below the warning, there is a navigation bar with tabs: "Vehicle Information", "Campaign", "Warranty", "BOL", "Vehicle Configuration Update" (highlighted with a blue box), "Service Entry", and "Customer Data".

Under the "Vehicle Configuration Update" tab, there is a section for "Inserting" with the following fields:

Part Number	Description	Serial Number

Below the table, there is a text input field for "We recommend you to enclose the explanatory notes".

At the bottom of the "Inserting" section, there are two buttons: "Add" and "Go To Non-genuine part/accessory".

At the very bottom of the form, there is a table header for a list of records:

Part Number	Description	Serial Number	Note
Records not found			

提交保修索赔并关闭保养条目

更新车辆参数

单击“车辆配置更新”(Vehicle configuration update) 选项卡后，在“零件编号”(Part Number) 字段中输入原装新部件的零件编号（与车辆原装配零件编号不同），或单击“转到非原装零件/附件”(Go To Non-genuine part/ accessory) 按钮，输入非原装零件编号。

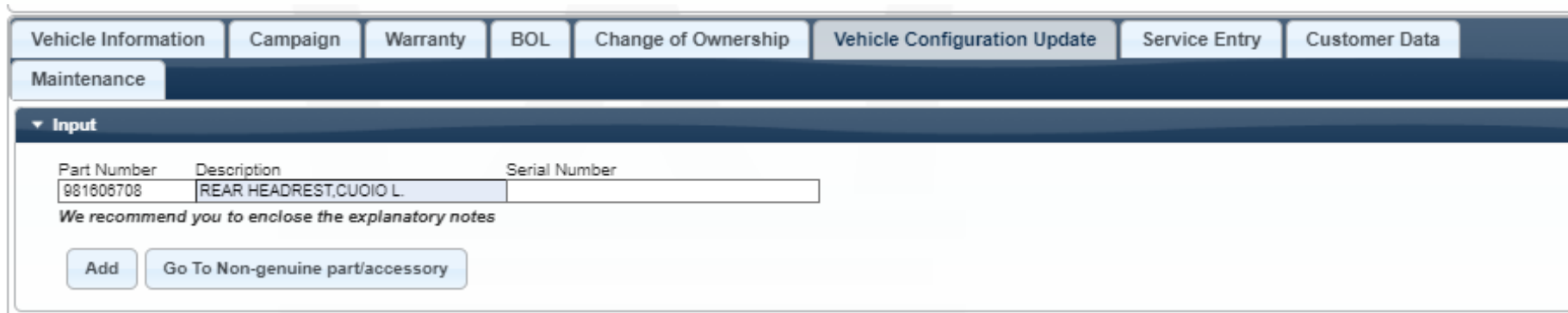

The screenshot shows a software interface with several tabs at the top: Vehicle Information, Campaign, Warranty, BOL, Change of Ownership, Vehicle Configuration Update (selected), Service Entry, and Customer Data. Below the tabs is a 'Maintenance' section with a dropdown menu set to 'Input'. The input form contains three columns: Part Number, Description, and Serial Number. The Part Number field is populated with '981606708' and the Description field with 'REAR HEADREST,CUOIO L.'. Below the form, there is a note: 'We recommend you to enclose the explanatory notes'. At the bottom of the form, there are two buttons: 'Add' and 'Go To Non-genuine part/accessory'.

然后，单击“添加”(Add) 按钮，登记相关线。



This screenshot shows the same interface as the previous one, but the 'Add' button is highlighted with a blue box. Below the input form, a table displays the added part information:

Part Number	Description	Serial Number	Note
981606708	REAR HEADREST,CUOIO L.		 

提交保修索赔并关闭保养条目

更新车辆参数

要输入关于更换/安装的说明，请单击“注释”图标。

Part Number	Description	Serial Number
981606708	REAR HEADREST,CUOIO L	

We recommend you to enclose the explanatory notes

然后，输入注释并单击“保存” (Save)。

Vehicle Information Campaign Warranty BOL Change of Ownership Vehicle Configuration Update Service Entry Customer Data

Maintenance

Replacement date: 16.11.2023 Part Number: 981606708 Description: APPOGGIAT.POST.CPL.CUOIO Serial Number: [Empty]

Note: abcdefghijklm

提交保修索赔并关闭保养条目

保养条目关闭

输入所有所需信息后，单击“保存”(Save)按钮，保养条目状态将变为“已关闭”(Closed)。

1. Vehicle Entry 2. Repair 3. Close

▼ Close

Service Entry #	Opening date	Last Update	Days down	Vehicle Downtime	Previous Repair#
IT0098595	16.11.2023	24.11.2023 - WBTESTHQ2	8	1	2

Chassis no.	Plate #	Repair Order#	Repair order opening date	Mileage In
327800	FV358HT	LEVANTE S	54321	16.11.2023 Km 25200

Status
C - Closed

Last Punch Date	Repair order closing date	Mileage Out
23.11.2023	23.11.2023	25230

Issues fixed at first time (FRFT)
Yes No 1 selected

Back to list Check Save Summary Authorization request Authorization request history

Warning



如果由于存在一条或多条可删除阻止消息而无法保存保养条目，请单击“授权请求”(Authorization request)按钮，按照本手册“管理保养条目阻止警告”部分中所述的程序进行操作。

提交保修索赔并关闭保养条目

发送索赔

关闭保养条目后，您可以选择索赔行并单击“保存” (Save) 按钮来发送保修索赔。

1. Vehicle Entry2. Repair3. Close

▼ Close

Service Entry #	Opening date	Last Update	Days down	Vehicle Downtime	Previous Repair#
IT0098595	18.11.2023	24.11.2023 - WBTESTHQ2	3	1	2

Chassis no.	Plate #	Repair Order#	Repair order opening date	Mileage In
327800	FV358HT	LEVANTE S	54321	16.11.2023 Km 25200

Status
C - Closed

Last Punch Date	Repair order closing date	Mileage Out
23.11.2023	23.11.2023	25230

Issues fixed at first time (FRFT)
Yes No 1 selected

Back to listCheckSaveSummaryAuthorization requestAuthorization request history

Warning
Campaign to be performed

▼ Warranty to be sent

<input checked="" type="checkbox"/>	5	Campaign	61190001	PROGRAMMED IGNITION CONTROL UN	Claim 1
<input checked="" type="checkbox"/>	6	Campaign	61941090	PILOT SIDE FRONT SEAT CABLES	Claim 2
<input checked="" type="checkbox"/>	7	Campaign	61871223	MTC+ MODULE WITH DISPLAY	Claim 3
<input checked="" type="checkbox"/>	8	Campaign	61144001	FUEL VAPOUR FILTER	Claim 4

Send



如果由于存在任何可删除阻止消息而无法发送索赔，请单击“授权” (Authorization request) 按钮，按照本手册“管理保养条目阻止警告”部分中所述的程序进行操作。

如果尚未参加阻止活动，则无法发送任何索赔以期受理。

提交保修索赔并关闭保养条目

发送索赔

发送索赔后，“关闭”工作表中将显示一条成功发送消息。

1. Vehicle Entry2. Repair3. Close

Close

The claim no 1 has been correctly sent
The claim no 2 has been correctly sent
The claim no 3 has been correctly sent
The claim no 4 has been correctly sent

Service Entry #	Opening date	Last Update	Days down	Vehicle Downtime	Previous Repair#
IT0098595	18.11.2023	24.11.2023 - WBTSTHQ2	8	1	2

Chassis no.	Plate #	Repair Order#	Repair order opening date	Mileage In
327800	FV358HT	LEVANTE S	16.11.2023	Km 25200

Status
C - Closed

Last Punch Date	Repair order closing date	Mileage Out	Service Entry Closing Date
23.11.2023	23.11.2023	25230 Km <input checked="" type="radio"/> M <input type="radio"/>	24.11.2023

Issues fixed at first time (FRFT)
Yes No 1 selected

Back to listCheckSaveSummaryAuthorization requestAuthorization request history

Warning
WW0370:No Open Campaigns for this vehicle

Warranty to be sent

Records not found

Send



索赔必须在维修单关闭日期后 30 天内发送以期受理，渠道仅限保养条目。

无论保养条目处于“已打开”还是“已关闭”状态（请始终参阅状态栏），均可输入或删除索赔。

要发送索赔，保养条目必须始终处于“已关闭”状态

提交保修索赔并关闭保养条目

发送索赔

“已发送”通知也将出现在作业线行中。

The screenshot displays a software interface for managing repairs. At the top, there are three buttons: '1. Vehicle Entry', '2. Repair' (highlighted with a blue border), and '3. Close'. Below these is a dark blue bar with a 'Repair' button. The main area contains a table with the following columns: Ref., Repair Description, Component Code, Description, W/C/I, and a close button (X). The table lists four repair entries, each with a 'Defect code' and a 'Customer Complaint'.

Ref.	Repair Description	Component Code	Description	W/C/I	X
5	Campaign No. 00338	190001	PROGRAMMED IGNITION CONTROL UN	Warranty	<input type="checkbox"/>
83 - NOT TO SPECIFICATIONS		campaign			
6	Campaign No. 00342	941090	PILOT SIDE FRONT SEAT CABLES	Warranty	<input type="checkbox"/>
83 - NOT TO SPECIFICATIONS					
7	Campaign No. 00351	871223	MTC+ MODULE WITH DISPLAY	Warranty	<input type="checkbox"/>
83 - NOT TO SPECIFICATIONS					
8	Campaign No. 00368	144001	FUEL VAPOUR FILTER	Warranty	<input type="checkbox"/>
83 - NOT TO SPECIFICATIONS					

To the right of the main table is a summary table with columns: Activity, Status, and X.

Activity	Status	X
Repair 5		<input type="checkbox"/>
	Claim 1 Sent to factory	
Repair 6		<input type="checkbox"/>
	Claim 2 Sent to factory	
Repair 7		<input type="checkbox"/>
	Claim 3 Sent to factory	
Repair 8		<input type="checkbox"/>
	Claim 4 Sent to factory	

提交保修索赔并关闭保养条目

索赔状态

保修索赔可从“临时”（尚未发送）状态变为“工厂确认”/“拒绝”状态。

索赔状态可在 ModisCS+ 上的“保修管理”菜单（售后服务 (Aftersales)/保修 (Warranty)/保修管理 (Warranty Management)）中查看。

The screenshot shows the ModisCS+ interface for Warranty Management. The left sidebar contains a navigation menu with 'WARRANTY MANAGEMENT' highlighted. The main area features a search form with fields for Work order closure date, Sending claim date, Warranty Code, Dealer, Component, and Warranty #. Below the search form is a table of warranty claims with columns for Status, Country, Dealer, Chassis no., Service Entry #, Warranty #, CC, Work order closure date, Sending claim date, Repair Order #, Component, Importer Amount, Amount, and Note.

Status	Country	Dealer	Chassis no.	Service Entry #	Warranty #	CC	Work order closure date	Sending claim date	Repair Order #	Component	Importer Amount	Amount	Note
○	ITA	52222 ROSSOCORSA S.R.L.	327800	IT0098595	IT98595_4	23	23/11/23	24/11/23	54321	61144001	0,00 EURO	0,00 EURO	
○	ITA	52222 ROSSOCORSA S.R.L.	327800	IT0098595	IT98595_3	23	23/11/23	24/11/23	54321	61871223	40,50 EURO	40,50 EURO	
○	ITA	52222 ROSSOCORSA S.R.L.	327800	IT0098595	IT98595_2	24	23/11/23	24/11/23	54321	61941090	0,00 EURO	0,00 EURO	
○	ITA	52222 ROSSOCORSA S.R.L.	327800	IT0098595	IT98595_1	24	23/11/23	24/11/23	54321	61190001	24,30 EURO	24,30 EURO	
○	ITA	52222 ROSSOCORSA S.R.L.	420000	IT0098591	IT98591_3	22	13/10/23	13/10/23	86256	82410005	269,34 EURO	269,34 EURO	
○	ITA	52222 ROSSOCORSA S.R.L.	392207	IT0098594	IT98594_1	34	06/10/23		89561	61010021	295,16 EURO	295,16 EURO	
○	ITA	52222 ROSSOCORSA S.R.L.	392207	IT0098593	IT98593_1	35	06/10/23		8976556	61010400	284,75 EURO	284,75 EURO	
○	ITA	52222 ROSSOCORSA S.R.L.	401339	IT0098590	IT98590_9	34	02/10/23		86283	61010400	60,75 EURO	60,75 EURO	
○	ITA	52222 ROSSOCORSA S.R.L.	401339	IT0098590	IT98590_8	34	02/10/23		86283	61010081	1067,80 EURO	1147,85 EURO	
○	ITA	52222 ROSSOCORSA S.R.L.	401339	IT0098590	IT98590_6	35	02/10/23	02/10/23	86283	61010400	98,30 EURO	98,30 EURO	

Warning: highlighted lines refer to edited warranties

主要索赔状态列表

Claim Status	
Code	Description
Temporary	
C	Sent by dealer to Subsidiary/ 1st Level Dealer
F	Sent to Factory (by 1st Level Dealer)
I	Returned to dealer
P	Partially confirmed
R	Rejected
FF	Confirmed by Factory



管理保养条目阻止警告

管理保养条目阻止警告

在保养条目的不同工作表中，您可以找到阻止警告和信息性警告。

- 阻止警告可以是：

- 1) 与特定车辆状态相关的阻止标记
- 2) 与未遵守的政策相关的阻止警告

阻止警告总是以灰色突出显示。

- 信息性警告位于“保养条目”和“维修”工作表中，以粉红色突出显示。

1. Vehicle Entry 2. Repair 3. Close

Vehicle Entry

Service Entry #	Opening date	Last Update	Days down	Vehicle Downtime	Previous Repair#
		-	0	87	

Status: -

Dealer: 053214 - ITALCAR SERVICE S.N.C.

Chassis no.	Plate #	Customer Name	Actual Owner
92401	ET737LC	客户姓名	Yes <input type="radio"/> No <input type="radio"/>

Repair Order#: Repair order opening date: Mileage In: Km M Vehicle towed in due to technical issues: Yes No

Service Note:

Check Save Bulletins Knowledge on Line

WW0125:Please select YES/NO to define the actual owner

WW0222:Repair order number missing

WW0467:Repair order opening date missing

WW0235:Mileage In missing

WW0363:Please select YES/NO to define if vehicle towed in

Warning

WW0370:No Open Campaigns for this vehicle

Vehicle with more than 10 visits in the workshop

If the flag "actual owner" was incorrectly selected,please contact your ABM

管理保养条目阻止警告

与车辆状态相关的阻止标记包括：

- **CRM 案例 (CRM)**
- **通用阻止标记 (GEN)**
- **已导出 (EFM)**
- **已撞毁 (INC)**
- **已报废 (ROT)**
- **已被盗 (RUB)**
- **已修改里程数 (KMM)**
- **已改装 (MOD)**
- **不定期保养 (MNG)**
- **发动机控制单元已改装 (CMM)**



管理保养条目阻止警告

CRM 案例标记 (CRM)

- “CRM” 标记用于内部信息。
- 我们在重要客户案例中添加该标记，当不再需要将该客户作为重要客户进行管理时，可以将其移除。
- 该标记不允许在没有 ABM 干预的情况下打开保养条目。

当我们在“车辆条目”工作表中查询带有“CRM”标记的 VIN 时，会出现阻止警告，无法找到该车的任何相关信息。如果客户不再被视为重要客户，请要求您的相关 ABM 删除该标记！

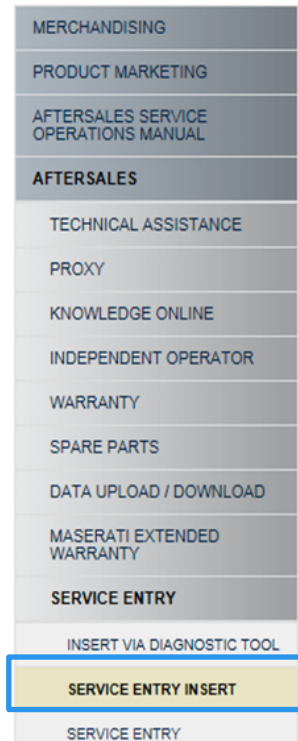

The 'Vehicle Entry' form is shown with three tabs: '1. Vehicle Entry', '2. Repair', and '3. Close'. The '1. Vehicle Entry' tab is active. The form contains the following fields and options:

Service Entry #	Opening date	Last Update	Days down	Vehicle Downtime	Previous Repair#
		-	0	4	

Additional fields and options include:

- Status: -
- Dealer: [Dropdown]
- Chassis no.: 250547, Plate #: 684354567, LEVANTE, Customer Name: [Field], Actual Owner: Yes No
- Repair Order#: [Field], Repair order opening date: [Field], Mileage In: Km M [Field], Vehicle towed in due to technical issues: Yes No
- Service Note: [Text Area]

Below the form, there is an 'Inquiry' button and a warning message highlighted with a blue box:

WW0520:Warranty blocked: please contact your ABM

Below the warning, there are three lines of text:

- WW0370:No Open Campaigns for this vehicle
- WW0777:Contact MNA Consumer Affrs
- If the flag "actual owner" was incorrectly selected,please contact ABM/RAM

管理保养条目阻止警告

通用标记 (GEN)

- “通用” 标记用于跟踪车辆的通用信息；当我们查询 VIN 时，其会出现在“车辆条目”工作表中。
- 当我们不想要/不需要再跟踪车辆时，可以移除该标记。

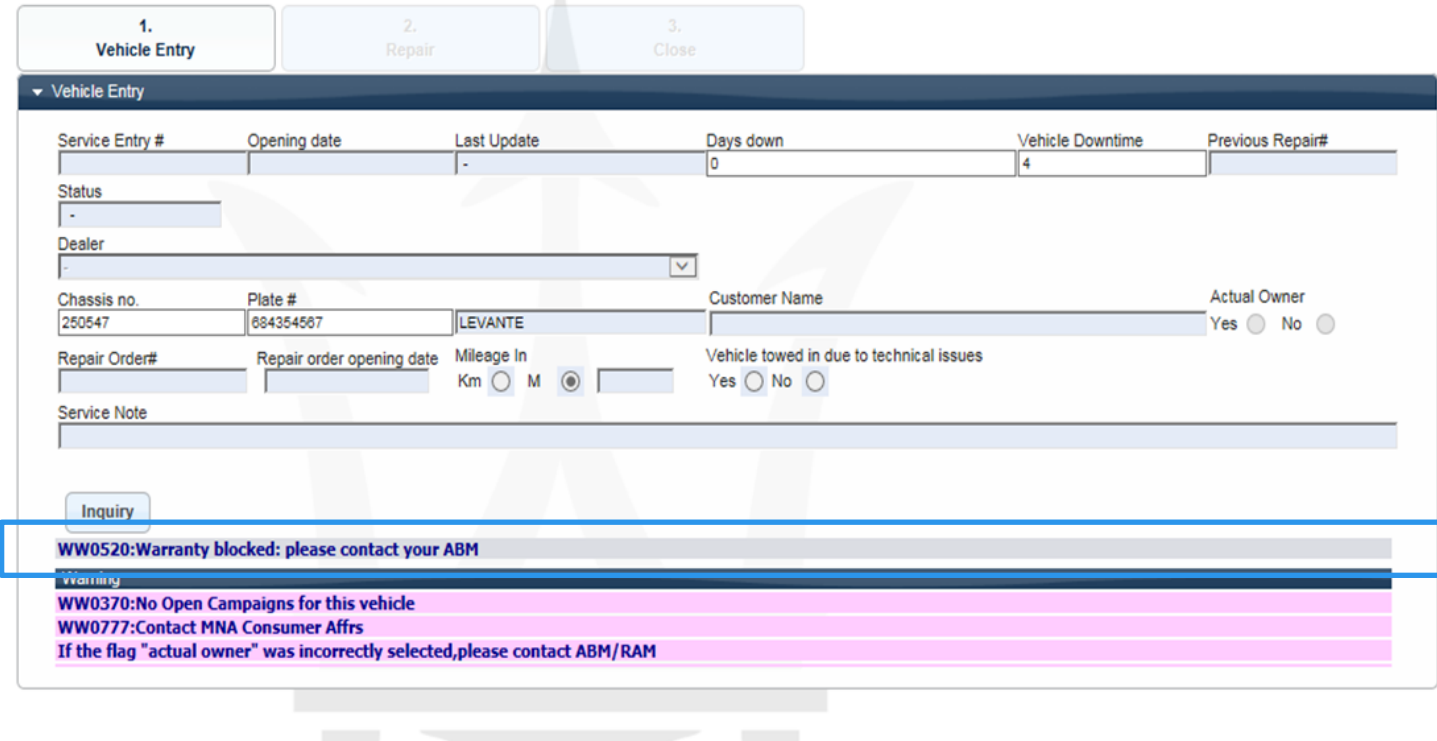
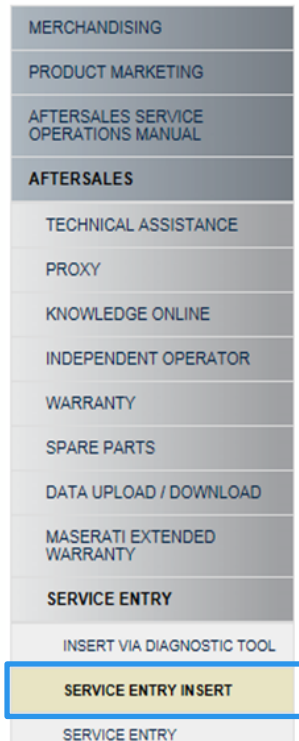

管理保养条目阻止警告

出口至/进口自国外市场标记 (EFM)

- 当车辆进口自/出口至与原厂保修条件不同的国家/地区（例如从美国出口到欧洲市场）时：

- 您（新市场经销商）无法看到车辆的相关信息，也无法打开保养条目；
- 阻止警告（灰色）“WW0520: 保修受阻” (WW0520: Warranty blocked) 出现在保养条目的“车辆条目”工作表中；
- 如果车辆尚未被标记为“EFM”，您必须联系相关 ABM，以便将车辆分配到新市场并标记为 EFM。

The screenshot shows a software interface for vehicle entry. At the top, there are three tabs: "1. Vehicle Entry", "2. Repair", and "3. Close". The "Vehicle Entry" tab is active. Below the tabs, there is a form with the following fields:

Service Entry #	Opening date	Last Update	Days down
		-	0

Below the table, there are several input fields:

- Status: -
- Dealer: -
- Chassis no.: 92752
- Plate #: 1
- Customer Name: M157 V6 350 RWD US
- Repair Order#: -
- Repair order opening date: -
- Mileage In: Km M
- Vehicle towed in d: Yes No
- Service Note: -

At the bottom of the form, there is an "Inquiry" button. Below the form, there is a warning message highlighted in a blue box:

WW0520:Warranty blocked: please contact your ABM

Warning

Campaign to be performed
If the flag "actual owner" was incorrectly selected, please contact ABM/RAM
One or more Privacy consents are missing. Please present our Policy to the customer and request o

管理保养条目阻止警告

出口至/进口自国外市场标记 (EFM)

- 分配 EFM 标记后，车辆保修期满；召回活动只可在保修期内进行。
- 维修活动可由客户付费执行，您只能要求赔付管理费用（输入工时代码 0200200 和成本代码 23）。有关更多详细信息，请参阅通函 MAS000461 “针对带有 EFM 标记的车辆的保养条目和保修索赔的政策更新”。

- 激活 EFM 标记后，允许打开保养条目。
- 只有当我们有证据证明该车已返回原产地市场时，才可移除该标记。

1. Vehicle Entry 2. Repair 3. Close

Vehicle Entry

Service Entry #	Opening date	Last Update
		-

Status
-

Dealer
-

Chassis no. Plate #
144148 1 M157 V6 410 AWD US

Repair Order# Repair order opening date Mileage In
Km M

Mobility services provided
Yes No

Service Note

Check Save Bulletins Knowledge on Line

Warning
WW0370: No Open Campaigns for this vehicle
WW0489: Exported to Foreign Market (EFM): Warranty blocked, contact ABM for info



输入 EFM 标记后，在第一个保养条目步骤中将出现一个信息性警告（以粉红色突出显示）。如果您尝试在“维修”工作表中输入非活动索赔，则警告将变为阻止警告（灰色）

管理保养条目阻止警告

已撞毁标记 (INC)

- 将因事故和以下原因而遭受严重损坏的车辆标记为“已撞毁”：
 1. 车辆无法修理；
 2. 客户未授权进行修理；
 3. 客户将车辆的维修委托给无法保证维修质量的非授权经销商。
- 当您查询被标记为“已撞毁”的 VIN 时，“车辆条目”工作表中会出现一个信息性警告，“车辆信息”部分也会出现一个注释。
- 当一辆无法维修的已撞毁汽车进入您的车间时，请联系您的 ABM 或子公司的保修部门，向其添加“已撞毁”标记并进行跟踪。

1. Vehicle Entry 2. Repair 3. Close

Vehicle Entry

Service Entry #	Opening date	Last Update	Days dt
		-	0

Status
-

Dealer
-

Chassis no. Plate # Ghibli Custom

289722 HP-FA 400

Repair Order# Repair order opening date Mileage In Vehicle technici

Km M Yes Yes

Mobility services provided Open C

Yes No Yes

Service Note

Check Save Bulletins Knowledge on Line

Warning
No Open Campaigns for this vehicle
EW0013:Accidented vehicle, please contact directly Factory Aftersales department

Services Type	Start Date	End Date
Warranty	12/13/2017	12/13/2020

Note
INC Crashed car -Warranty blocked

Print Change Request Warranty/ Reprint Labels

管理保养条目阻止警告

已撞毁标记 (INC)

- 任何被标记为“已撞毁”车辆有效保修期满，召回活动只可在保修期内进行。
- 维修活动可由客户付费执行；您只能要求赔付管理费用（工时代码 0200200，成本代码 23）。
- 您可以要求退还预付保养费（成本代码 35）。
- 如果您尝试为被标记为“已撞毁”的 VIN 输入新的保养条目，请单击“保存” (Save)，警告将变为灰色（阻止）。
- 如果您必须输入保养条目进行干预（由客户付费）和/或活动，请联系您的 ABM 或子公司的保修部门临时解锁 VIN。

The screenshot displays a software interface for entering vehicle service records. At the top, there are three buttons: '1. Vehicle Entry', '2. Repair', and '3. Close'. Below these is a dropdown menu labeled 'Vehicle Entry'. The main form area contains several fields and sections:

- WW0268: Repairer area different from market of sale** (highlighted in yellow)
- Table with columns: Service Entry #, Opening date, Last Update, Days down. The 'Days down' field contains the value '0'.
- Status: -
- Dealer: 052222 - ROSSOCORSA S.R.L.
- Chassis no.: 289722, Plate #: HP-FA 400, Ghibli, Customer Name: [empty]
- Repair Order#: 345678, Repair order opening date: 19.10.2020, Mileage In: 33333 (with radio buttons for Km, M, O), Vehicle towed in due to technical issues: Yes (radio), No (radio).
- Service Note: Water leaks
- Buttons: Check, Save, Bulletins, Knowledge on Line
- WW0031: Crashed car (warranty blocked)** (highlighted with a blue box)
- Warning** (highlighted in dark blue)
- WW0370: No Open Campaigns for this vehicle** (highlighted in pink)
- EW0013: Accidented vehicle, please contact directly Factory Aftersales department** (highlighted in pink)
- If the flag "actual owner" was incorrectly selected, please contact ABM/RAM** (highlighted in pink)



客户必须签署一份告知书 (Maserati 免责声明)，以便执行召回和维修活动。

如果被标记为“已撞毁”的车辆由授权经销商进行维修，或授权经销商证明在授权网络之外进行的维修符合 Maserati 标准，则可解锁该车。

管理保养条目阻止警告

已被盗标记 (RUB)

- 当我们收到警方或保险公司发出的车辆被盗通知时，会添加“已被盗”标记。
- 该标记激活后，将阻止保修和保养条目打开。
- 只有当我们可以证明该车已找回（需要警方报告）时，才可移除该标记。

- 当您查询被标记为“已被盗”的 VIN 时，会出现阻止警告，您将无法查看车辆信息。
- 有关阻止警告的详细信息，请联系您的 ABM。

The screenshot displays the ModisCS+ software interface for a Maserati dealer. The main window is titled 'SERVICE ENTRY INSERT' and shows a form for entering a new service entry. The form is divided into three steps: 1. Vehicle Entry, 2. Repair, and 3. Close. The 'Vehicle Entry' step is currently active. The form contains several fields for data entry, including Service Entry #, Opening date, Last Update, Days down, Vehicle Downtime, Previous Repair#, Status, Dealer, Chassis no., Plate #, Customer Name, Actual Owner (Yes/No), Repair Order#, Repair order opening date, Mileage In (Km/M), and Vehicle towed in due to technical issues (Yes/No). A 'Service Note' field is also present. Below the form, there is an 'Inquiry' button and a warning message: 'WW0520: Warranty blocked: please contact your ABM'. Below this, there is a pink banner with the text: 'Warning WW0370: No Open Campaigns for this vehicle. If the flag "actual owner" was incorrectly selected, please contact ABM/RAM. One or more Privacy consents are missing. Please present our Policy to the customer and request consents.'

管理保养条目阻止警告

已报废标记 (ROT)

- “已报废”标记仅适用于已撞毁车辆，需要出示证明已报废的官方文件。
- 如果仍然有效，则所有车辆部件保修期满。
- 官方文件确认报废后，即可从任何存在待执行活动的停车场中删除 VIN。
- 当您尝试为被标记为“已报废”的 VIN 输入保养条目时，会出现阻止警告。
- 您也可以“车辆信息”部分找到关于该车状态的说明。

The screenshot displays a 'Vehicle Entry' form with the following sections:

- Navigation:** 1. Vehicle Entry (highlighted), 2. Repair, 3. Close.
- Warnings:**
 - WW0268: Repairer area different from market of sale
 - WW0261: This car covers on average over 100 km per day
- Table:**

Service Entry #	Opening date	Last Update	Days down
		-	0
- Fields:** Status, Dealer (052222 - ROSSOCORSA S.R.L.), Chassis no. (225703), Plate # (XXXXXX), Customer Name (LEVANTE), Repair Order# (257654), Repair order opening date (20.10.2020), Mileage In (66666), Vehicle towed in due to technical issues (Yes/No).
- Buttons:** Check, Save, Bulletins, Knowledge on Line.
- Warning:** WW0384: Car total loss (highlighted).
- Warning:** WW0370: No Open Campaigns for this vehicle. If the flag "actual owner" was incorrectly selected, please contact ABM/RAM.
- Table:**

Service Type	Start Date	End Date
Warranty	27.06.2019	27.06.2022
- Table:**

ROT	Total loss
-----	------------
- Bottom Right:** Q8FA FIX&GO TYRE KIT(RUB), QSEK COMPULSORY PACK T, R002 HEADLINER & PILLARS, STVH STEERING WHEEL & S, Vehicle Configuration Update.

管理保养条目阻止警告

已修改里程数标记 (KMM)

- 如果有证据证明里程数已修改（仪表板上的里程数与 ECU 中存储的服务历史记录/数据不一致），则必须使用“已修改里程数 (KMM)”标记。
- 添加该标记后，任何有效保修均将失效。
- 激活该标记后，您可以：
 - 打开新的保养条目
 - 同时就召回（成本代码 24）和维修（成本代码 23）活动进行索赔
 - 要求退还预付保养费（成本代码 35）
 - 输入由客户付费的干预作业线
- “车辆信息”部分存在有关该状态的说明。

Service Entry #	Opening date	Last Update	Days down
		-	0

Status
-

Dealer
-

Chassis no. | Plate # | LEVANTE DIESEL | Customer Name
26101 | MVETUBA | | RATTIUCES PETER

Repair Order# | Repair order opening date | Mileage in | Vehicle towed in due to technical
| | Km M | Yes No

Service Note

Check Save Bulletins Knowledge on Line

Warning
WW0370: No Open Campaigns for this vehicle
If the flag "actual owner" was incorrectly selected, please contact ABM/AM

Warranty	Service Type	Start Date	End Date
Warranty		30.11.2017	30.11.2020

KMM KMM Modified Mileage

Replacement date	Part Number
18.04.2019	046334875 MOTORE CPL V6 275/250 DIESEL M161

管理保养条目阻止警告

已修改里程数标记 (KMM)

1. Vehicle Entry

2. Repair

3. Close

Vehicle Entry

Service Entry #	Opening date	Last Update	Days down
		-	0

Status: -

Dealer: -

Chassis no.: 281071 | Plate #: MV67LBA | Customer Name: LEVANTE DIESEL | RAFFAELLE BERTOLI

Repair Order#: | Repair order opening date: | Mileage in: Km M | Vehicle towed in due to technical: Yes No

Service Note:

Check Save Bulletin Knowledge on Line

Warning
WW0370: No Open Campaigns for this vehicle
If the flag "actual owner" was incorrectly selected, please contact ABM/RAM

Warranty	Service Type	Start Date	End Date
Warranty		30.11.2017	30.11.2020

Notes:

<input checked="" type="checkbox"/>	KMM Modified Mileage
-------------------------------------	----------------------

Vehicle Configuration Update	Replacement date	Part Number
Q84V REAR PRIVACY LAMINATED GLASS	18.04.2019	046334876 MOTORE CPL V6 275/250 DIESEL M161
Q8J5 COMPULSORY PACK UK/0Y		
RO02 HEADLINER & PILLARS		094084297
8TVAH STEERING WHEEL & SHIFTER		094084351



添加“KMM”标记后，要继续打开新的保养条目，您必须输入仪表盘上当前显示的里程数。

有关更多详细信息，请参阅通函 MAS000988 “管理里程数已修改的车辆”和 MAS000661 “保养条目改进 - 作业线插入和新车状态 KMM”

管理保养条目阻止警告

已改装标记 (MOD)

- 当我们有证据（图片、维修单或其他文件）证明一个或多个车辆部件被改装时，将在车辆上添加“已改装 (MOD)”标记。
- 受改装影响的部件保修期满。
- 召回和维修活动均可执行，除非与改装部件有关。
- 您可以要求退还预付保养费（成本代码 35）。
- 当您查询带有“MOD”标记的 VIN 时，车辆数据可用；“车辆信息”工作表中仅报告说明。

1. Vehicle Entry | 2. Repair | 3. Close

Vehicle Entry

Vehicle Information | Campaign | Warranty | BOL | Service Entry | Maintenance

Vehicle Information			Finish			
Chassis no.	303137		External Color	94084200	NERO	
Vehicle	757861040	3.0 BT V6 2WD 430 HP GS USA	Internal Color	94084311	RED/BLACK	
V.I.N.	ZAM57YSAXJ1303137		Carpets	94084217	BLACK/BLACK BELT	
Assembly #	5088722		Vehicle	WHS	MSRP	
Model Year	2018		3.0 BT V6 2WD 430 HP GS USA	74,381.000	79,980.000	
PDI Status	Marketing Card		Option List			
Finishing date	05/15/2018		Code	Colour Code	WHS	MSRP
Arrival Date	06/18/2018		UPPER			
Engine	Type	Number	DSHG	DASHBOARD/CLUSTER BROW	094084334	BLACK/RED/BLACK
Gearbox	M156E	417515	KDFG	DEFAULT COMPLEMENTARY OPT.GH		
Ing. key	M0418	0572955	QR65	MTC Plus With Navi		
Immo Code	8916		QRF9	Dark Mirror Interior Trim		
Sales Country	U.S.A.		QXAN	Blind Spot Detection		
Wheel Size	N/A		Q01K	Nerissimo Pack		1,740.000 2,000.000
Tyre DOT 1	XBTOT7515017		Q143	All-Season Tires 20"		365.000 420.000
Tyre DOT 2	XBTOT7515017		Q47A	Red Brake Calipers		696.000 800.000
Tyre DOT 3	XB6FT7524117		Q40J	Home Link		
Tyre DOT 4	XB6FT7524017		Q407	Shift Padd. On Steering Column		479.000 550.000
Radio Sri#	T00BE081890023		Q5CA	Solid Paint		
Dealer	6163	JD EUROPEAN AUTO INC	Q508	Front And Rear Parking Sensors		
Certificate of Origin	267918		Q6BN	Sport St Wheel Black Leather		
Customer Name	63680	MASERATI NORTH AMERI	Q6YE	Remote Start Function		
Invoice Ref.	40539		Q728	Full Natural Leather		2,001.000 2,300.000
Invoice Ref.	05/16/2018		Q856	20" Urano Gloss Black		
Warranty			ROO1	HEADLINING AND PILLARS	094084295	BLACK
Services Type	Start Date	End Date	STL1	LEATHER STEERING WHEEL	094084213	BLACK/BLACK
Warranty	08/16/2018	08/16/2022	Vehicle Configuration Update			
Notes			Replacement date	Part Number	Number	
MOD Modified Car			Records not found			

Print | Change Request Warranty/ Reprint Labels

* Actual selling price may vary. Dealer prep., transportation, taxes, title, license and registration fees not included if not explicitly stated.

管理保养条目阻止警告

已改装标记 (MOD)

相反，如果您尝试保存保养条目，则会出现阻止警告，如果您不向负责评估是否可以在保修期内进行任何维修操作的您的 ABM 寻求支持，则无法继续操作。



如果我们有证据证明所有改装部件均已更换，且车辆符合 Maserati 标准，则可取消标记。

1. Vehicle Entry | 2. Repair | 3. Close

Vehicle Entry

Service Entry #	Opening date	Last Update	Days down	Vehicle Downtime	Previous Repair#
		-	0	0	0

Status: -

Dealer: 052222 - ROSSOCORSA S.R.L.

Chassis no.: 001431 | Plate #: FPE175G | Customer Name: 客户姓名 | Actual Owner: Yes No

Repair Order#: 957654 | Repair order opening date: 20.10.2020 | Mileage in: Km M 77777 | Vehicle towed in due to technical issues: Yes No

Service Note: Engine noise

Check Save Bulletin Knowledge on Line

WW0256: Modified Car

Warning

WW0370: No Open Campaigns for this vehicle
If the flag "actual owner" was incorrectly selected, please contact ABM/ RAM
One or more Privacy consents are missing. Please present our Policy to the customer and request consents.

管理保养条目阻止警告

发动机控制单元已改装 (CMM)

当 MDEVO 连接显示检查结果不正常 (CVN 不正确) 时, 将出现一个弹出窗口, 显示“检测到发动机可能异常, 请打开一个支持请求 Blue On Line” (Possible engine anomaly detected, please open a Support Request Blue On Line) 消息:

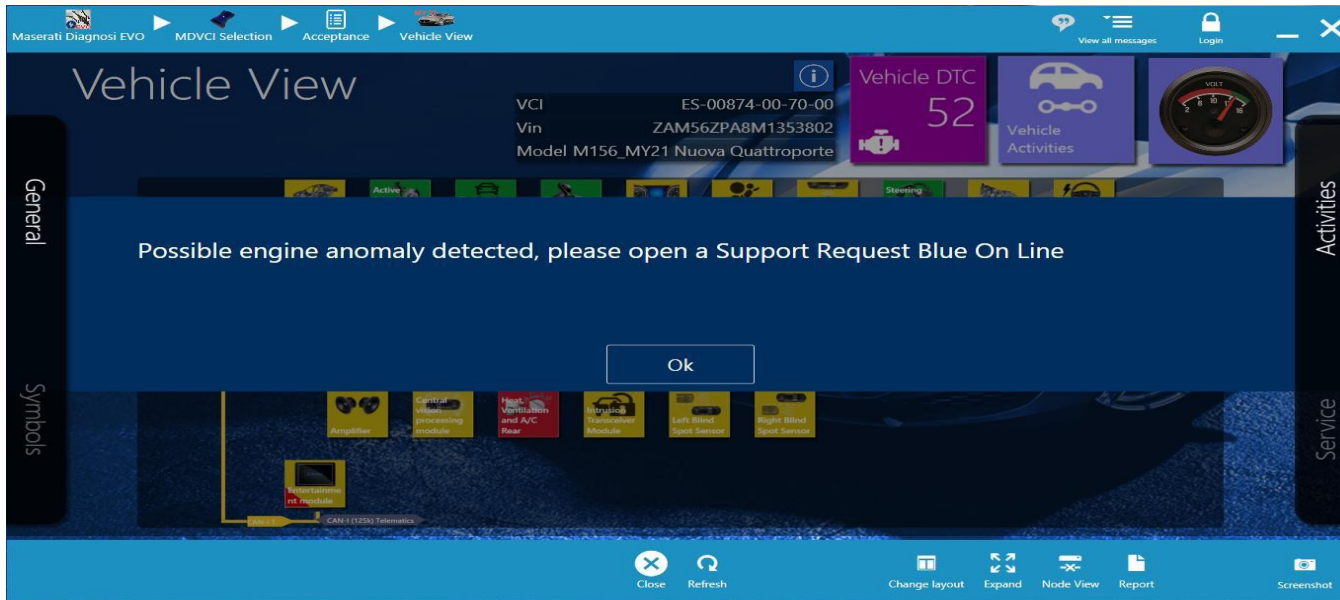

与 ECM 调整相关的阻止错误无法通过本手册中描述的“已阻止索赔解锁请求”程序进行管理。有关处理这些错误的更多信息, 请参阅通函 MAS002544 “检查发动机控制模块 (ECM) 参数”

管理保养条目阻止警告

发动机控制单元已改装 (CMM)

检查结果不正常会导致车辆被自动阻止并标记 CMM：发动机控制单元已改装（标记尚不可见）。

打开保养条目后，您将只能以以下方式打开作业线：

异常 - 发动机 - 发动机控制单元 (1.90.001) - 客户

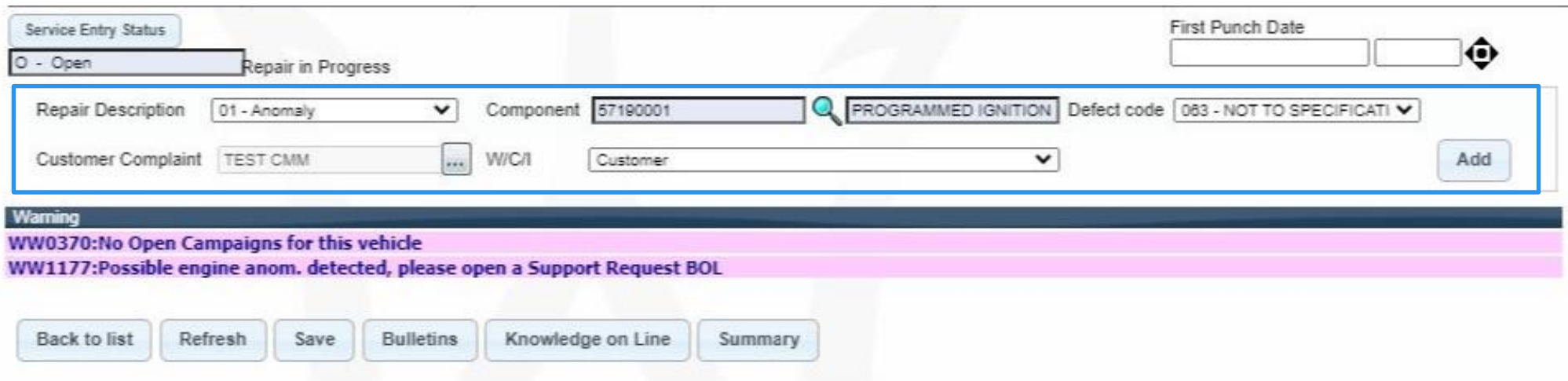

The screenshot displays a service entry form with the following fields and options:

- Service Entry Status:** A dropdown menu with "O - Open" selected and "Repair in Progress" as an alternative option.
- First Punch Date:** Two empty input boxes for date and time, accompanied by a calendar icon.
- Repair Description:** A dropdown menu with "01 - Anomaly" selected.
- Component:** An input field containing "57190001" with a magnifying glass icon.
- Defect code:** A dropdown menu with "083 - NOT TO SPECIFICATI" selected.
- Customer Complaint:** An input field containing "TEST CMM" with a three-dot menu icon.
- W/C/I:** A dropdown menu with "Customer" selected.
- Add:** A button to save the entry.

Warning: A pink banner displays the following messages:

- WW0370:No Open Campaigns for this vehicle
- WW1177:Possible engine anom. detected, please open a Support Request BOL

Buttons: A row of buttons at the bottom includes "Back to list", "Refresh", "Save", "Bulletins", "Knowledge on Line", and "Summary".

管理保养条目阻止警告

发动机控制单元已改装 (CMM)

如果保养条目已打开，则可能有以下两种情况：

1. 调整已确认 -> BOL 请求将关闭，“CMM: 发动机控制单元已改装” (CMM: Engine Control Unit modified) 警告消息（粉红色）将自动出现在保养条目中。

The screenshot shows a service entry form with a blue box highlighting the 'Service Entry Status' dropdown menu, which is currently set to 'Open'. Below the form, a warning message is displayed in a pink bar: 'Warning WW0370: No Open Campaigns for this vehicle WW1178: CMM: Engine Control Unit modified'. The form includes fields for 'Repair Description', 'Component', 'Defect code', 'Customer Complaint', and 'W/C/I', along with an 'Add' button. At the bottom, there are two tables. The first table lists repair details, and the second table shows activity and status.

Ref.	Repair Description	Component Code	Description	W/C/I	
	Defect code		Customer Complaint		
3	Anomaly	190001	PROGRAMMED IGNITION ECU	Customer	<input type="checkbox"/>

Activity	Status	
Repair 3	BOL 000000001981617	Closed <input type="checkbox"/>

2. 调整未确认 -> 在关闭请求之前，BOL 专家必须要求总部保修部门移除 CMM 标记。因此，不会显示新的警告消息。

注：只有在 ECM 部件上打开作业线并关闭 BOL 后，才可在其他部件上打开其他作业线。

管理保养条目阻止警告

发动机控制单元已改装 (CMM)

如果保养条目已关闭，则可能有以下两种情况：

1.调整已确认，发动机控制单元上的 BOL（已关闭）存在，CMM 标记激活：

“CMM: 发动机控制单元已改装” (CMM: Engine Control Unit modified) 信息警告（粉红色）出现在保养条目中。

The screenshot shows a web interface for vehicle management. At the top, there are fields for 'Status' (set to 'C - Closed') and 'First Punch Date' (set to '09.03.2021' and '07.41'). Below these are search and filter fields for 'Repair Description', 'Component', 'Defect code', and 'Customer Complaint'. A 'W/C/I' dropdown and an 'Add' button are also present. A pink warning banner is displayed with the text: 'Warning WW0370:No Open Campaigns for this vehicle WW1178:CMM: Engine Control Unit modified'. At the bottom of the form area, there are buttons for 'Back to list', 'Refresh', 'Save', 'Bulletins', 'Knowledge on Line', and 'Summary'.

Ref.	Repair Description	Component Code	Description	W/C/I	✕
	Defect code	Customer Complaint			
3	Anomaly	190001	PROGRAMMED IGNITION ECU	Customer	<input type="checkbox"/>
63 - NOT TO SPECIFICATIONS		TEST CMM			

Activity	Status	✕
Repair 3	BOL 000000001981617 Closed	<input type="checkbox"/>

管理保养条目阻止警告

发动机控制单元已改装 (CMM)

不允许就功能组 1 和 3 的部件提交索赔：将出现“行动未被允许：发动机控制单元已改装，无法提交索赔 xxx” (Action not allowed: Engine Control Unit modified, claim xxx cannot be submitted) 阻止消息（灰色）。

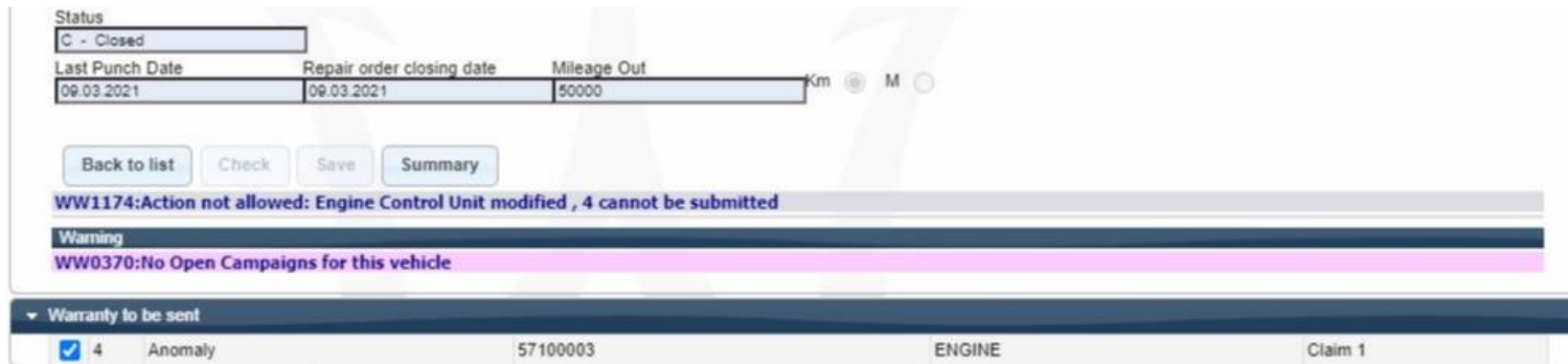

The screenshot displays a vehicle management interface. At the top, the status is 'C - Closed'. Below this, a table shows the last punch date (09.03.2021), repair order closing date (09.03.2021), and mileage out (50000). There are buttons for 'Back to list', 'Check', 'Save', and 'Summary'. A warning message is displayed: 'WW1174: Action not allowed: Engine Control Unit modified, 4 cannot be submitted'. Below this, another warning is shown: 'WW0370: No Open Campaigns for this vehicle'. At the bottom, a table lists warranty items to be sent, including an anomaly with ID 57100003 related to the engine.

Status
C - Closed

Last Punch Date	Repair order closing date	Mileage Out
09.03.2021	09.03.2021	50000

Buttons: Back to list, Check, Save, Summary

Warning: WW1174: Action not allowed: Engine Control Unit modified, 4 cannot be submitted

Warning: WW0370: No Open Campaigns for this vehicle

Warranty to be sent				
<input checked="" type="checkbox"/>	4	Anomaly	57100003	ENGINE
				Claim 1

管理保养条目阻止警告

发动机控制单元已改装 (CMM)

2.调整未确认，发动机控制单元上的 BOL 不存在/未关闭，CMM 标记激活（您忽略了第一条信息或关闭了保养条目而未关闭 BOL 请求）：

- “保养条目”中出现“检测到发动机可能异常” (Possible engine anomaly detected) 警告消息（粉红色）。该消息与保养条目打开时出现的消息类似，但打开 BOL 的请求缺失，因为保养条目关闭后，无法再打开 BOL。

The screenshot displays a software interface for vehicle management. At the top, there are fields for 'Status' (set to 'C - Closed') and 'First Punch Date' (09.03.2021 07.41). Below these are input fields for 'Repair Description', 'Component', 'Defect code', and 'Customer Complaint', along with a 'W/C/I' dropdown and an 'Add' button. A prominent pink warning banner reads: 'Warning WW0370:No Open Campaigns for this vehicle WW1179:Possible engine anomaly detected'. Below the warning are buttons for 'Back to list', 'Refresh', 'Save', 'Bulletins', 'Knowledge on Line', and 'Summary'. At the bottom, there are two tables. The left table lists repair entries with columns for Ref., Repair Description, Component Code, Description, and W/C/I. The right table shows activity and status for 'Repair 3' and 'Repair 4', including a 'Claim 1 Temporary' entry.

Ref.	Repair Description	Component Code	Description	W/C/I	
	Defect code	Customer Complaint			
3	Anomaly	190001	PROGRAMMED IGNITION ECU	Customer	<input type="checkbox"/>
63	- NOT TO SPECIFICATIONS	TEST CMM			
4	Anomaly	100003	ENGINE	Warranty	<input type="checkbox"/>
12	ENGINE KNOCKING - BAD IGNITION	TEST CMM			

Activity	Status	
Repair 3		<input type="checkbox"/>
Repair 4		<input type="checkbox"/>
Claim 1 Temporary		

管理保养条目阻止警告

发动机控制单元已改装 (CMM)

- 不允许就功能组 1 和 3 的部件提交索赔：

将显示“行动未被允许：检测到发动机异常，无法提交索赔 xxx” (Possible engine anomaly detected, claim xxx cannot be submitted) 警告阻止消息（灰色）。

The screenshot displays a vehicle warranty management interface. At the top, the status is 'C - Closed'. Below this, there are fields for 'Last Punch Date' (09.03.2021), 'Repair order closing date' (09.03.2021), and 'Mileage Out' (50000). There are radio buttons for 'Km' (selected) and 'M'. Below the fields are buttons for 'Back to list', 'Check', 'Save', and 'Summary'. A warning message is displayed in a grey box: 'WW1180:Action not allowed: possible engine anomaly detected, 4 cannot be sent.' Below this is a pink warning box: 'Warning WW0370:No Open Campaigns for this vehicle'. At the bottom, there is a table titled 'Warranty to be sent' with one row containing a checked checkbox, the number '4', the text 'Anomaly', the ID '57100003', the category 'ENGINE', and the claim number 'Claim 1'.

Warranty to be sent					
<input checked="" type="checkbox"/>	4	Anomaly	57100003	ENGINE	Claim 1

管理保养条目阻止警告

发动机控制单元已改装 (CMM)

一般信息

- 如果客户自费更换发动机控制单元和相关损坏部件，您必须在 BOL 请求中附上证明更换和/或维修的发票。
- 文件检查完成后，CMM 标记将被移除。如果 BOL 已关闭，则只能在保养条目打开的情况下重新打开。
- 如果未更换发动机控制单元，并且车辆上的 CMM 标记仍处于活动状态，您可以打开后续的新保养条目，而无需为 CMM 标记打开新的 BOL。您可以打开任何作业线，请记住，根据政策，功能组 1 和 3 的部件必须位于“客户类型”下。
- 如果 CMM 标记已激活的车辆已超过保修期/延长保修期/CPO 至少 2 年，则在打开保养条目时，BOL 不具有强制性。您可以打开任何作业线，请记住，根据政策，功能组 1 和 3 的部件必须位于“客户类型”下。

管理保养条目阻止警告

与未遵守政策时出现的阻止错误相关的主要警告如下：

- **WW010**：行动未被允许。索赔确认延迟
- **WW0069**：活动待执行
- **WW0279**：BOL 缺失
- **WW0267**：车上存在打开的保养条目



管理保养条目阻止警告

阻止错误“WW0010: 行动未被允许。索赔确认延迟”

- 当自维修单和相关保养条目关闭之日起超过 30 个日历日提交索赔时，会出现此阻止错误。
- 当您尝试在维修单关闭 30 天后发送索赔时，其会显示在“关闭”工作表中。



如果存在客观问题导致延迟，请发送取消阻止请求，以就阻止索赔发送进行评估。

1. Apertura		2. Intervento		3. Chiusura	
Chiusura					
SE Numero	Aperta il	Ultima Modifica	Days down	Fermo Storico	Precedenti Passaggi D'officina
IT0058970	25.10.2019	03.09.2020 - TITTEMP01	1	33	8
Matricola	Targa	Ordine Riparazione	Data apertura ordine di riparazione	Percorrenza Ingresso	
194888	A SZ 1166	LEVANTE DIESEL	31119	25.10.2019	Km 98115
Stato					
C - Chiusa					
Data Fine Lavoro	Data chiusura ordine di riparazione	Percorrenza Uscita	Km <input checked="" type="radio"/> M <input type="radio"/>	Data chiusura Service Entry	
25.10.2019	25.10.2019	98142		25.10.2019	
Torna alla lista Controlla Salva Sommaro					
WW0010:Azione non consentita: Ritardo nella conferma claim					
Warning Informativi					
WW0370:Non esistono campagne aperte per questa vettura					
Vettura con piu' di 10 passaggi in officina					
Garanzie da inviare					
<input checked="" type="checkbox"/>	1	Anomalia	61171001	NOURICE	Garanzia 1
Invia					

管理保养条目阻止警告

阻止错误“WW0069：活动待执行”

- 当车辆上有一个或多个强制活动仍待执行时，将出现阻止警告“WW0069：活动待执行”(WW0069: Campaign to be performed)。
- 当您在保养条目“车辆条目”工作表中查询 VIN 时，将显示信息性警告（以粉红色突出显示）。
- 打开“活动”(Campaign)工作表，您可以看到所有阻止活动（以蓝色突出显示）。

1. Vehicle Entry

2. Repair

3. Close

Vehicle Entry

Service Entry #	Opening date	Last Update	Days down	Vehicle Downtime	Previous Repair#
			0	0	

Status
-

Dealer
-

Chassis no. 180000 Plate # CH18LU CHN Customer Name -- Actual Owner Yes No

Repair Order# Repair order opening date Mileage in Km M Vehicle towed in due to technical issues Yes No

Service Note

Check Save Bulletins Knowledge on Line

Warning
WW0069: The VIN has been previously repaired on date 01.01.0001.
Campaign to be performed
If the flag "actual owner" was incorrectly selected, please contact ABM/RAM
One or more Privacy consents are missing. Please present our Policy to the customer and request consents.

Vehicle Information Campaign Warranty BOL Service Entry

管理保养条目阻止警告

阻止错误“WW0069：活动待执行”

- 关闭保养条目后，如果强制活动的一个或多个索赔尚未提交，则警告将变为阻止警告（以灰色突出显示），并且任何其他索赔发送都将被阻止。



如果存在客观问题导致强制活动未执行，请发送取消阻止请求，以就阻止索赔发送进行评估。

1. Vehicle Entry 2. Repair 3. Close

Close

Service Entry #	Opening date	Last Update	Days down	Vehicle Downtime	Previous Repair#
BG0000789	18.11.2019	27.11.2019 - BG00000	1	1	2
Chassis no.	Plate #	Repair Order#	Repair order opening date	Mileage In	
238010	LEVANTE S	658	18.11.2019	Km 40532

Status
C - Closed

Last Punch Date	Repair order closing date	Mileage Out	Km	M	Service Entry Closing Date
18.11.2019	18.11.2019	40535	<input checked="" type="radio"/>	<input type="radio"/>	27.11.2019

Back to list Check Save Summary

WW0069: Campaign to be performed

Warning

WW0656: The VIN has been previously repaired on date 30.10.2019 Campaign to be performed

Warranty to be sent

<input checked="" type="checkbox"/>	1	Anomaly	61141042	LOWER RH. AIR DUCTING	Claim 1
<input checked="" type="checkbox"/>	2	Anomaly	61610003	RH FRONT LOWER LEVER	Claim 2

Send

管理保养条目阻止警告

阻止错误“WW0279: BOL 缺失”

- 根据保修政策（指导列表、超出部件成本金额等），在提交索赔之前强制打开 BOL 请求，当您未输入该请求时，则会出现此阻止错误。
- 该阻止错误出现在“保修”工作中。
- 在这种情况下，相关字段中缺少 BOL 编号。

The screenshot displays a software interface for managing warranty claims. At the top, there are tabs for 'INFO', 'REPAIR', 'BOL+', and 'WARRANTY'. A blue box highlights the error message 'WW0279: BOL is missing' in the top navigation bar. Below this, the 'Repair' section contains various fields: Warranty # (BH2739_1), Dealer (63742 - EURO MOTORE), Repair Order # (12898), Chassis no. (99718), M156 V6 410 RWD ME MY14, Assembly # (004012125), Service Entry # (BH0002739), Date in (03.02.2020), Mileage (62132), Creation claim date (04.02.2020), Submit date HQ/Importer, Confirmation claim date, Service Warranty Start Date (20.08.2014), and Warranty End Date (20.08.2017). The 'Defect' section shows Cost Code (28 - ABM Goodwill), Campaign #, Component (934005), PASSENGER'S SIDE FF, and Defect (238 - DIRT INC). A blue box highlights the 'BOL' field, which is currently set to 'N/A' and has a dropdown menu showing 'BOL 2 Not Available'. The 'Labour Code' section shows [0 Element inserted] with a table for recording labor. The 'Spare Part Replaced' section shows [3 Element inserted] with a table for recording parts.

Code	Description	Hours	Amount	Adj. %	Reason of Adjustment
	Straight time				

Code	Description	Quantity	Amount	Part Return Causes	Adj. %	Reason of Adjustment
070038120	FRONT RH DOOR WINDOW GLASS	1	236.34	Not required		
070038131	FRONT LH DOOR WINDOW GLASS	1	236.34	Not required		
073004374	KIT R.H. + L.H. FRONT DOOR WIN	1	276.90	Not required		

管理保养条目阻止警告

阻止错误“WW0279: BOL 缺失”

- 在以下条件下，可以将当前索赔链接到在先前保养条目中打开的 BOL:

- VIN 相同。
- 新作业线中的部件代码（异常相同）。
- 前一个 BOL 请求关闭日期和新维修单打开日期之间的间隔时间不超过 45 天。

- 检查“BOL 2”下拉菜单中是否有先前关闭的 BOL，如果有，可以链接到当前索赔。

The screenshot displays a software interface for managing vehicle repairs and warranties. It features several tabs: INFO, REPAIR, BOL+, and WARRANTY. The 'Repair' section contains fields for Warranty # (IT15716_1), Dealer, Repair Order # (2112212), Creation claim date (30.11.2018), Chassis no. (LEVANTE DIESEL), Assembly # (006053181), Submit date HQ/Importer, Service Entry # (IT0015716), Confirmation claim date, Date in (30.11.2018), Service Warranty Start Date (29.06.2018), Mileage (12000), and Warranty End Date (29.06.2021). The 'Defect' section includes Cost Code (16 - Regular warranty), Campaign #, Component (RH ENGINE FASTENING), and a 'BOL 2' dropdown menu with the value '00000000573850' selected. The 'Labour Code' section shows a table with columns for Code, Description, Hours, Amount, Adj. %, and Reason of Adjustment. The 'Spare Part Replaced' section shows a table with columns for Code, Description, Quantity, Amount, Part Return Causes, Adj. %, and Reason of Adjustment. A blue circle highlights the 'BOL 2' dropdown menu.



仅当保养条目处于“已打开”状态（请始终参阅状态栏）时，才可填写或重新打开 BOL，除非通过 IT 请求，否则其无法删除。

如果存在客观问题导致索赔中出现 BOL 缺失，请联系 ABM 评估是否可以解除阻止。

管理保养条目阻止警告

阻止错误“**WW0267**: 这辆车有一个打开的保养条目，请联系 **ABM**（**MNA/MCAN** 的保修部门）”

• 当同一辆车有其他已打开保养条目时，将出现此阻止错误。在这种情况下：

- 您需要确保您的经销商尚未打开保养条目 -> 如果是，请使用打开的保养条目（因为每次车辆访问只可注册一个保养条目）。
- 如果您未找到您的经销商注册的打开的保养条目，很可能是其他经销商留下了打开的保养条目 -> 请联系您的 ABM 寻求帮助。

The screenshot shows a software interface for vehicle entry. At the top, there are three tabs: "1. Vehicle Entry", "2. Repair", and "3. Close". The "Vehicle Entry" tab is active. Below the tabs, there is a form with the following fields and values:

- Vehicle Entry** (dropdown menu)
- WW0221:Mileage > Km 150000** (highlighted in yellow)
- WW0261:This car covers on average over 100 km per day** (highlighted in yellow)
- Service Entry #**: [empty]
- Opening date**: [empty]
- Last Update**: [empty]
- Days down**: 0
- Vehicle Downtime**: 17
- Previous Repair#**: 8
- Status**: [empty]
- Dealer**: 052222 - ROSSOCORSA S.R.L. (dropdown menu)
- Chassis no.**: 241844
- Plate #**: 1n524yl
- Customer Name**: ARVAL SERVICE LEASE ITALIA SPA - ARVAL SERVICE LEASE ITALIA SPA
- Actual Owner**: Yes No
- Repair Order#**: 957854
- Repair order opening date**: 20.10.2020
- Mileage In**: Km M 555555
- Vehicle towed in due to technical issues**: Yes No
- Service Note**: Engine noise

At the bottom of the form, there are four buttons: "Check", "Save", "Bulletins", and "Knowledge on Line". Below the buttons, there is a warning message in a blue box:

WW0267:There is an open SE on this car, contact ABM (Warranty dept. for MNA/MCAN

Below the warning message, there are three more messages in a pink box:

- WW0370:No Open Campaigns for this vehicle**
- If the flag "actual owner" was incorrectly selected,please contact ABM/RAM**
- One or more Privacy consents are missing. Please present our Policy to the customer and request consents.**

管理保养条目阻止警告

已阻止索赔的解锁请求

当索赔中出现一个或多个阻止错误时，可单击“授权”(Authorization request) 按钮发送解锁评估请求。

注意：您只能在客观问题导致策略遵守失败的情况下发送请求。

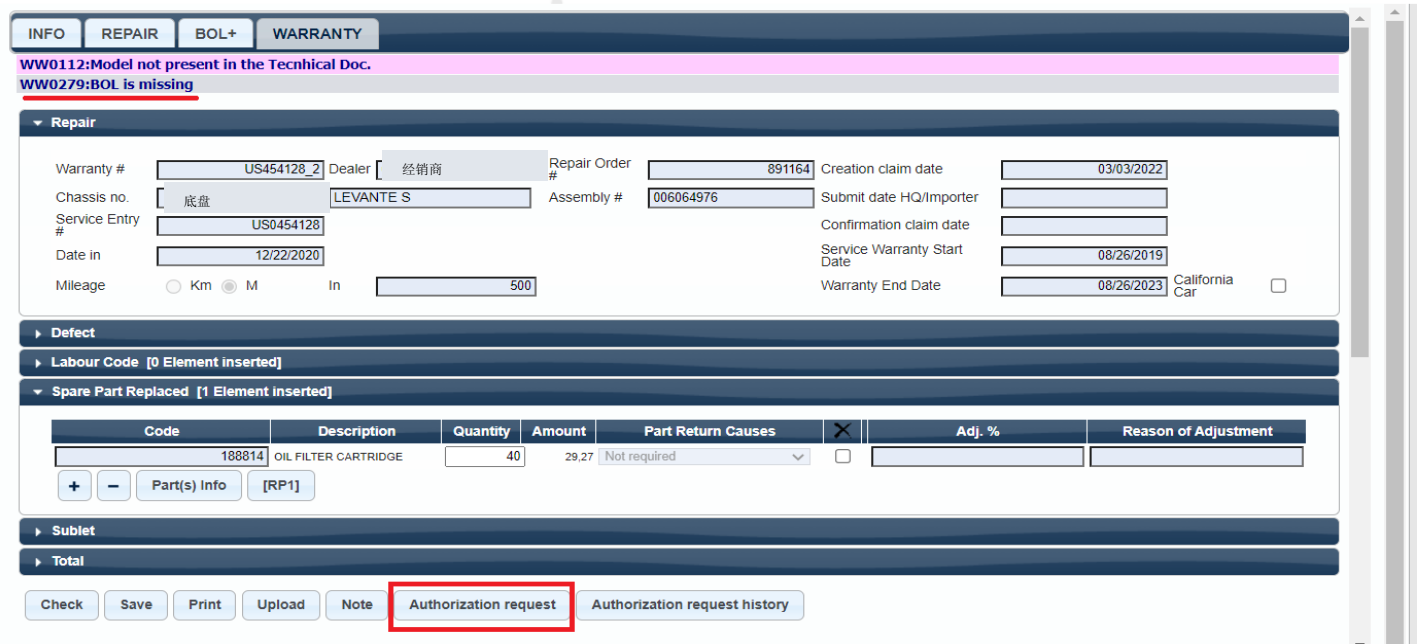

The screenshot displays a software interface for managing repair records. At the top, there are tabs for 'INFO', 'REPAIR', 'BOL+', and 'WARRANTY'. Below the tabs, there are two error messages: 'WW0112:Model not present in the Technical Doc.' and 'WW0279:BOL is missing'. The main section is titled 'Repair' and contains various input fields for warranty and repair details. At the bottom of the interface, there is a row of buttons: 'Check', 'Save', 'Print', 'Upload', 'Note', 'Authorization request', and 'Authorization request history'. The 'Authorization request' button is highlighted with a red border.

Code	Description	Quantity	Amount	Part Return Causes	Adj. %	Reason of Adjustment
188814	OIL FILTER CARTRIDGE	40	29.27	Not required		



与 ECM 调整相关的阻止错误无法通过此程序进行管理。

管理保养条目阻止警告

已阻止索赔的解锁请求

选择您为其发送请求的阻止错误，并写明原因。

Authorization request

Error messages

- WW0279 - WW0279:BOL is missing

Note (max. 500 characters)

Lorem ipsum dolor sit amet, consectetur adipiscing elit. Aenean commodo ligula eget dolor. Aenean massa. Cum sociis natoque penatibus et magnis dis parturient montes, nascetur ridiculus mus. Donec quam felis, ultricies nec, pellentesque eu, pretium quis, sem. Nulla consequat massa quis enim. Donec pede justo. fringilla vel, aliquet nec, vulputate eget, arcu. In enim justo, rhoncus ut, imperdiet a, venenatis vitae, justo. Nullam dictum felis eu pede mollis pretium. Integer tincidunt. Cras dapibu

Confirm Close

管理保养条目阻止警告

已阻止索赔的解锁请求

发送请求后，该索赔将在保养条目“2.维修” (2. Repair) 工作表中以蓝色突出显示。

The screenshot displays a software interface for managing vehicle repairs. At the top, there are three tabs: "1. Vehicle Entry", "2. Repair", and "3. Close". The "2. Repair" tab is active, showing a detailed view of a repair entry for Service Entry # US0454128. The entry includes fields for Opening date (12/22/2020), Last Update (03/04/2022 - USCLLE02), Days down (438), Vehicle Downtime (0), and Previous Repair#. Below this, there are fields for Chassis no, Plate # (m23710), Repair Order# (891164), Repair order opening date (12/22/2020), and Mileage In (M 500). A "Service Entry Status" dropdown is set to "O - Open". A "Warning" banner at the bottom of the form reads "WW0370:No Open Campaigns for this vehicle".

Below the form is a table with two main sections. The left section is a table of repair activities, and the right section is a table of claim statuses.

Ref.	Repair Description	Component Code	Description	W/C/I	Activity	Status
1	Maintenance Program	010021	1ST SERVICE	Warranty	Repair 1	
0 - CHECKS					Claim 1 Temporary	
2	Anomaly	010011	1ST SERVICE	Warranty	Repair 2	
6 - FISSURE - PUNCTURE	test				Claim 2 Temporary	

管理保养条目阻止警告

已阻止索赔的解锁请求

发送请求后，Maserati 评估负责人将收到一封电子邮件*，其中包含索赔编号、经销商数据和请求原因说明。

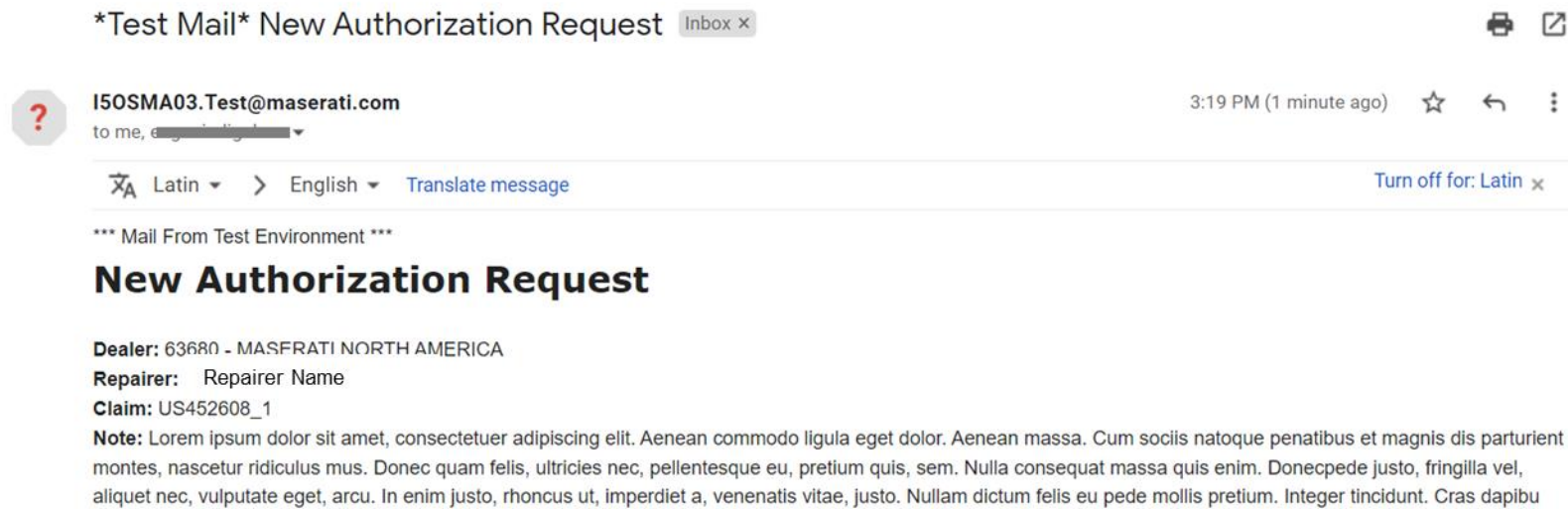

Test Mail New Authorization Request Inbox x Print Share

 **I5OSMA03.Test@maserati.com** 3:19 PM (1 minute ago) Star Reply More

to me, 

 Latin > English [Translate message](#) [Turn off for: Latin x](#)

*** Mail From Test Environment ***

New Authorization Request

Dealer: 63680 - MASFRATI NORTH AMERICA
Repairer: Repairer Name
Claim: US452608_1

Note: Lorem ipsum dolor sit amet, consectetur adipiscing elit. Aenean commodo ligula eget dolor. Aenean massa. Cum sociis natoque penatibus et magnis dis parturient montes, nascetur ridiculus mus. Donec quam felis, ultricies nec, pellentesque eu, pretium quis, sem. Nulla consequat massa quis enim. Donec pede justo, fringilla vel, aliquet nec, vulputate eget, arcu. In enim justo, rhoncus ut, imperdiet a, venenatis vitae, justo. Nullam dictum felis eu pede mollis pretium. Integer tincidunt. Cras dapibu

管理保养条目阻止警告

已阻止索赔的解锁请求

请求获得批准后，“授权编号”将自动输入到已阻止索赔中。

The screenshot displays a web application interface for managing warranty claims. The 'Repair' tab is active, showing various fields for warranty details. A red box highlights the 'N/A Authorization # 16312' field in the 'Defect' section.

Repair				
Warranty #	US454128_2	Dealer	6125 - THE COLLECTION	
Repair Order #	891164	Creation claim date	03/03/2022	
Chassis no.	底盘	LEVANTE S	Assembly #	006064976
Submit date HQ/Importer		Confirmation claim date		
Service Entry #	US0454128	Service Warranty Start Date	08/26/2019	
Date in	12/22/2020	Warranty End Date	08/26/2023	
Mileage	<input type="radio"/> Km <input checked="" type="radio"/> M	In	500	
California Car	<input type="checkbox"/>			

Defect				
Cost Code	16 - Regular warranty	Campaign #		
BOL		<input checked="" type="checkbox"/> N/A Authorization #	16312	
Component	010011	1ST SERVICE	BOL2	Not Available
Repair technically authorized		Defect	006 - FISSUR	

Labour Code [0 Element inserted]
Spare Part Replaced [1 Element inserted]
Sublet
Total

Check Save Print Upload Note Authorization request Authorization request history

管理保养条目阻止警告

已阻止索赔的解锁请求

您将通过电子邮件*收到批准通知。

From: <15OSMA03.Test@maserati.com>
Date: Wed, Mar 2, 2022 at 3:50 PM
Subject: *Test Mail* Request Approved
To: <maserati@maserati.com>

*** Mail From Test Environment ***

Request Approved

Dear F██████████, your Request has been Approved .

Request ID: US452608_1

Type: Claim

Note: Lorem ipsum dolor sit amet, consectetur adipiscing elit. Aenean commodo ligula eget dolor. Aenean massa. Cum sociis natoque penatibus et magnis dis parturient montes, nascetur ridiculus mus. Donec quam felis, ultricies nec, pellentesque eu, pretium quis, sem. Nulla consequat massa quis enim. Donec pede justo, fringilla vel, aliquet nec, vulputate eget, arcu. In enim justo, rhoncus ut, imperdiet a, venenatis vitae, justo. Nullam dictum felis eu pede mollis pretium. Integer tincidunt. Cras dapibu

Approver Reason:

* 通知电子邮件会发送到提交请求的用户所关联的地址。

管理保养条目阻止警告

已阻止索赔的解锁请求

相反，如果请求被拒绝，您将通过电子邮件收到拒绝通知。

注意：如果请求被拒绝，您将能够为同一索赔发送新请求。

From: <15OSMA03.Test@maserati.com>
Date: Wed, Mar 2, 2022 at 4:05 PM
Subject: *Test Mail* Request Refused
To: <organizationalname@maserati.com>

*** Mail From Test Environment ***

Request Refused

Dear [\[REDACTED\]](#), your Request has been Rejected .

Request ID: US453711_1

Type: Claim

Note: Lorem ipsum dolor sit amet, consectetur adipiscing elit. Aenean commodo ligula eget dolor. Aenean massa. Cum sociis natoque penatibus et magnis dis parturient montes, nascetur ridiculus mus. Donec quam felis, ultricies nec, pellentesque eu, pretium quis, sem. Nulla consequat massa quis enim. Donec pede justo, fringilla vel, aliquet nec, vulputate eget, arcu. In enim justo, rhoncus ut, imperdiet a, venenatis vitae, justo. Nullam dictum felis eu pede mollis pretium. Integer tincidunt. Cras dapibu

Approver Reason: Lorem ipsum dolor sit amet, consectetur adipiscing elit. Aenean commodo ligula eget dolor. Aenean massa. Cum sociis natoque penatibus et magnis dis parturient montes, nascetur ridiculus mus. Donec quam felis, ultricies nec, pellentesque eu, pretium quis, sem. Nulla consequat massa quis enim. Donec pede justo, fringilla vel, aliquet nec, vulputate eget, arcu. In enim justo, rhoncus ut, imperdiet a, venenatis vitae, justo. Nullam dictum felis eu pede mollis pretium. Integer tincidunt.

Cras dapibu

* 通知电子邮件会发送到提交请求的用户所关联的地址。

管理保养条目阻止警告

已阻止索赔的解锁请求

单击索赔中的“授权请求历史记录” (Authorization request history) 按钮，您可以找到为该索赔提交的请求列表。

The screenshot displays a software interface for managing repair records. At the top, there are tabs for 'INFO', 'REPAIR', 'BOL+', and 'WARRANTY'. Below these, a pink banner displays the warning: 'WW0112:Model not present in the Technical Doc. WW0279:BOL is missing'. The main section is titled 'Repair' and contains various input fields for warranty and repair details. At the bottom of the interface, a row of buttons includes 'Check', 'Save', 'Print', 'Upload', 'Note', 'Authorization request', and 'Authorization request history'. The 'Authorization request history' button is highlighted with a red rectangular border.

Code	Description	Quantity	Amount	Part Return Causes	Adj. %	Reason of Adjustment
188814	OIL FILTER CARTRIDGE	40	29.27	Not required		

管理保养条目阻止警告

已阻止索赔的解锁请求

在出现的弹出窗口中，单击放大镜可以查看请求的详细信息。

注意：选择相关“取消”(Cancel)框，可以删除尚未处理的请求。

The screenshot displays a software interface with a modal dialog box titled "Authorisation request history". The dialog box contains a table with the following data:

Id #	Request number	Insert Date	Status	Authorization No.	Detail View	Cancel
1	US000094942	02/24/2022	New			

Below the table, there is a "Close" button. In the background interface, there is a "Close" button and an "Authorization request history" button, both highlighted with red boxes. The background interface also shows a list of tabs: INFO, REPAIR, BOL+, and WARRANTY. Below the tabs, there are two error messages: "WW0112:Model not present in the Technical Doc." and "WW0279:BOL is missing".

管理保养条目阻止警告

已阻止保养条目的解锁请求

对于索赔，只有在特殊情况下，您才可以发送解锁保养条目请求，方法是单击“3.关闭”(3. Close)工作表。

1. Vehicle Entry 2. Repair **3. Close**

Close

Service Entry #	Opening date	Last Update	Days down	Vehicle Downtime	Previous Repair#
US0454668	11/24/2021	03/04/2022 - USCLLE02	1	0	

CHASSIS	Plate #	Repair Order#	Repair order opening date	Mileage In
		GHIBLI S Q4	12312	11/24/2021
M 11				

Status
C - Closed

Last Punch Date	Repair order closing date	Mileage Out	km	M	Service Entry Closing Date
11/24/2021	11/24/2021	13	<input type="radio"/>	<input checked="" type="radio"/>	11/24/2021

Back to list Check Save Summary **Authorization request** Authorization request history

WW0010: Operation is not allowed: delay in confirmation claim

Warning
WW0370: No Open Campaigns for this vehicle

Warranty to be sent

<input checked="" type="checkbox"/>	2	Anomaly	57010012	1ST SERVICE	Claim 2
-------------------------------------	---	---------	----------	-------------	---------

Send

管理保养条目阻止警告

已阻止保养条目的解锁请求

选择您为其发送请求的阻止错误，并写明原因。

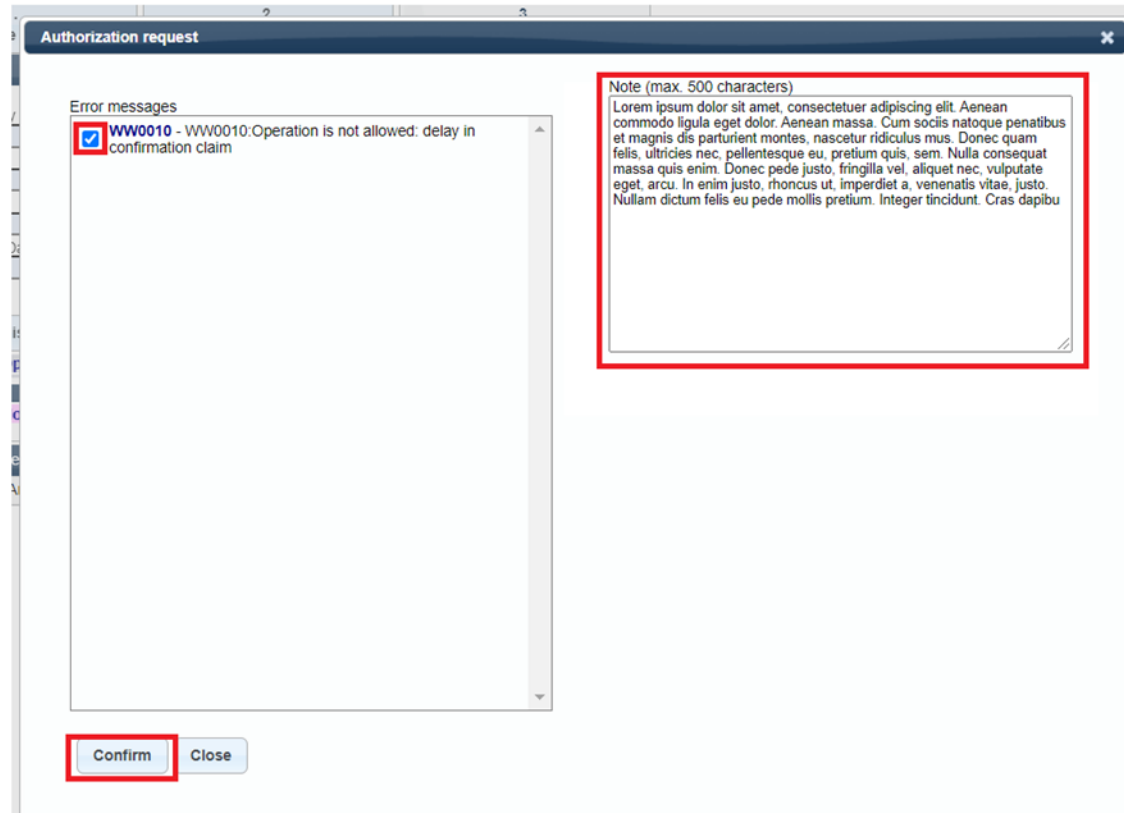

管理保养条目阻止警告

已阻止保养条目的解锁请求

发送请求后，保养条目将以蓝色突出显示。

The screenshot displays a search interface for repair orders. At the top, there are filters for 'Repair in Progress' (20), 'Repair on Hold' (11), and 'Closed with claims to be completed' (2126). Below these are input fields for 'Chassis no.', 'Service Entry #', 'Repair Order #', 'Service Entry Status' (set to 'All'), 'BOL #', 'Open Customer Case' (set to 'All'), and 'Repair order opening date' (From and To). A 'Search' button is located at the bottom left of the filter section.

	Service Entry #	Repair Order#	Chassis no.	Date	Mileage	Date	Mileage	Service Entry Status
	US0454668	12312	359928	11/24/2021	11 M	11/24/2021	13 M	Closed

管理保养条目阻止警告

已阻止保养条目的解锁请求

对于索赔，您将直接通过电子邮件*收到批准或拒绝通知。

注意： 如果被拒绝，您将能够为同一保养条目发送新请求。

From: <I5OSMA03.Test@maserati.com>
Date: Wed, Mar 2, 2022 at 3:50 PM
Subject: *Test Mail* Request Approved
To: <[REDACTED]@maserati.com>

*** Mail From Test Environment ***
Request Approved

Dear F [REDACTED], your Request has been Approved .

Request ID: US452608_1

Type: Claim

Note: Lorem ipsum dolor sit amet, consectetur adipiscing elit. Aenean commodo ligula eget dolor. Aenean massa. Cum sociis natoque penatibus et magnis dis parturient montes, nascetur ridiculus mus. Donec quam felis, ultricies nec, pellentesque eu, pretium quis, sem. Nulla consequat massa quis enim. Donec pede justo, fringilla vel, aliquet nec, vulputate eget, arcu. In enim justo, rhoncus ut, imperdiet a, venenatis vitae, justo. Nullam dictum felis eu pede mollis pretium. Integer tincidunt. Cras dapibu

Approver Reason:

* 通知电子邮件会发送到提交请求的用户所关联的地址。

管理保养条目阻止警告

已阻止保养条目的解锁请求

单击保养条目中的“授权请求历史记录”(Authorization request history)，您可以找到为该保养条目提交的请求列表。

1. Vehicle Entry 2. Repair 3. Close

Close

Service Entry #	Opening date	Last Update	Days down	Vehicle Downtime	Previous Repair#
US0451605	12/03/2020	02/24/2022 - USCLLE02	449	11	3

Chassis no.	Plate #	Repair Order#	Repair order opening date	Mileage In
341519	M23736	GT CONV. SPORT USA 888912	12/03/2020	M 9219

Service Entry Status: Open Repair in Progress

Last Punch Date: Repair order closing date: Mileage Out: Km M

[Back to list](#) [Check](#) [Save](#) [Summary](#) [Authorization request](#) [Authorization request history](#)

Warning
WW0370:No Open Campaigns for this vehicle

Warranty to be sent

<input checked="" type="checkbox"/>	2	Anomaly	46010021	1ST SERVICE	Claim 2
-------------------------------------	---	---------	----------	-------------	---------

[Send](#)

管理保养条目阻止警告

已阻止保养条目的解锁请求

单击保养条目中的“授权请求历史记录”(Authorization request history)，您可以找到为该保养条目提交的请求列表。

注意：可以删除尚未处理的请求。

The screenshot displays a software interface for managing vehicle service entries. It features three tabs: '1. Vehicle Entry', '2. Repair', and '3.'. The '1. Vehicle Entry' tab is active, showing fields for Service Entry # (US0451605), Opening date (12/03/2020), Chassis no. (341519), and Plate # (M23736). A 'Service Entry Status' dropdown is set to 'O - Open'. A 'Warning' banner at the bottom states 'WW0370:No Open Campaigns for this vehicle'. A 'Warranty to be sent' section shows a checked checkbox for '2 Anomaly' with ID 46010021 and '1ST SERVICE'.

An 'Authorisation request history' pop-up window is overlaid on the '2. Repair' tab. It contains a table with the following data:

Id #	Request number	Insert Date	Status	Authorization No.	Detail View	Cancel
1	US000094943	02/24/2022	New			

The 'Detail View' and 'Cancel' buttons in the table are highlighted with red boxes. A 'Close' button is also highlighted with a red box at the bottom left of the pop-up window. In the main interface, the 'Authorization request history' button is also highlighted with a red box.



管理保养条目状态

管理保养条目状态

保养条目状态

保养条目状态包括：“已打开” (Open)、“已关闭” (Closed)、“删除” (Deleted) 和“维修暂停” (Repair on Hold)。您可以在“保养条目管理”主页上查看保养条目状态。



BRAND PORTAL
MERCHANDISING
PRODUCT MARKETING
WHITE BOOK AFTERSALES
AFTERSALES
TECHNICAL ASSISTANCE
PROXY
KNOWLEDGE ONLINE
WARRANTY
SPARE PARTS
DATA UPLOAD / DOWNLOAD
MASERATI EXTENDED WARRANTY
SERVICE ENTRY
INSERT VIA DIAGNOSTIC TOOL
SERVICE ENTRY INSERT
SERVICE ENTRY MANAGEMENT
MAINTENANCE & SERVICES
VIN WRITE
STOCK LOCATOR
REPORT
OWNER DOCUMENTATION
AUTHORIZATION APPROVAL
CRM
MASERATI ACADEMY

Search for

Repair in Progress: 1159 Repair on Hold: 125 Closed with claims to be completed: 23620

Chassis no. Service Entry # Dealer:

Service Entry Status: BOL # Repair Order #

Repair order opening date: From To Open Customer Case:

	Service Entry #	Repair Order#	Dealer	Chassis no.	In	Out	Service Entry Status
					Date	Mileage	
<input type="checkbox"/>	US0601898	47585	6335 MASERATI OF CENTRAL FLORIDA I	419583	08/07/2023	13066 M	0 M Repair on Hold Waiting parts
<input type="checkbox"/>	US0602383	127101	6280 MILLER MOTORCARS, INC	399025	08/10/2023	11947 M	0 M Repair on Hold Sublet
<input type="checkbox"/>	US0602483	16313	6097 ROHRICH EUROPEAN MOTORS, INC.	396394	08/11/2023	14967 M	0 M Repair on Hold Sublet
<input type="checkbox"/>	US0605553	1035	6545 UMANSKY AM, LLC	287285	08/30/2023	31211 M	0 M Repair on Hold Waiting parts
<input type="checkbox"/>	US0605599	6027768	6171 NORTHSIDE IMPORTS LLC	315426	08/30/2023	61841 M	0 M Repair on Hold Waiting for Tech. support BOL 000000003186982
<input type="checkbox"/>	US0605944	127600	6128 MILLER MOTORCARS INC.	334293	08/29/2023	27144 M	0 M Repair on Hold Waiting for Authorization
<input type="checkbox"/>	US0606674	230474	6082 ZEIGLER MOTORS, LLC	372174	09/05/2023	12575 M	0 M Repair on Hold Waiting parts
<input type="checkbox"/>	US0607103	442525	6391 GARFF SALT LAKE LLC	410507	09/07/2023	236 M	0 M Repair on Hold Waiting for Tech. support BOL 000000003163214
<input type="checkbox"/>	US0607312	1010946	6065 BAKER MOTOR CO. OF CHARLESTON	297446	09/09/2023	80375 M	0 M Repair on Hold Waiting parts
<input type="checkbox"/>	US0607586	38275	6358 CELEBRITY OF BERGEN, LLC	279153	09/11/2023	35433 M	0 M Repair on Hold Waiting for Authorization

2 / 13

有关保养条目状态的正确管理，请参阅通函：

- MAS003323 “保养条目管理：最佳实践”
- MAS003354 “保养条目管理：正确使用‘维修暂停’状态”
- MAS003513 “保养条目管理：新的‘暂停 - 等待技术支持’状态的自动切换和车辆故障天数警报”

管理保养条目状态

保养条目状态

单击“状态更改”(Status Changes)按钮，可以查看多个保养条目的状态更改。

Status	Reason	Operator	Operation Date	Status duration
Open		USTNKG09	09/14/2023	1
Repair on Hold	Waiting for Tech. support	US05513	09/15/2023	0
Open		SE_BOLWL	09/15/2023	7
Repair on Hold	Waiting for Tech. support	US05513	09/22/2023	0
Open		SE_BOLWL	09/22/2023	24
Repair on Hold	Waiting parts	USTNKG09	10/16/2023	3
Open		*INT.JOB*	10/19/2023	26
Closed		USTNKG09	11/14/2023	-

Vehicle Downtime: 4
Previous Repair#: 4

Actual Owner: Yes No

Owner Car: Yes No

Rental Car: Yes No

Buttons: Back to list, Save, Vehicle Report, Bulletins, Knowledge on Line

Warnings:

- WW0013: Current mileage less than the mileage on previous repair
- WW0230: Mileage has to greater than previous claims 2
- Warning
- WW0656: The VIN has been previously repaired on date 01.08.2023
- WW0370: No Open Campaigns for this vehicle
- One or more Privacy consents are missing. Please present our Policy to the customer and request consents.
- There is no Maserati Connect active subscription for this vehicle. Customer is eligible for the registration process.

管理保养条目状态

保养条目状态

要更改保养条目状态，请单击“2. ‘维修’工作表” (2.Repair sheet) 中的“保养条目状态” (Service Entry Status) 按钮，然后从“新状态” (New Status) 下拉菜单中选择新状态。

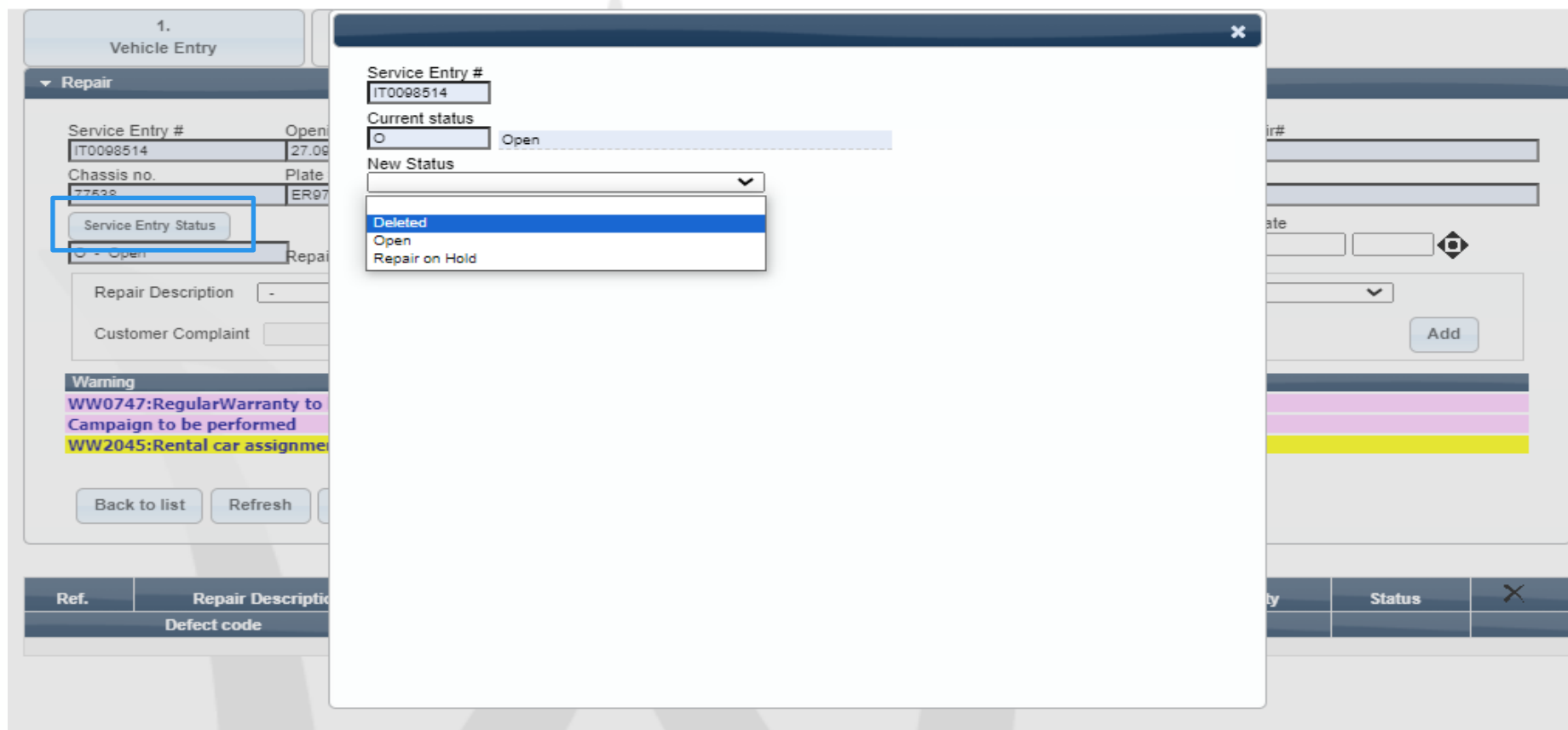

管理保养条目状态

“已打开”状态

在“车辆条目”(Vehicle Entry)工作表中插入并保存所有主要客户、车辆和车间访问数据后,保养条目即处于“已打开”状态。

1. Vehicle Entry 2. Repair 3. Close

Vehicle Entry

Service Entry #	Opening date	Last Update	Days down	Vehicle Downtime	Previous Repair#
IT0096689	16.03.2022	27.11.2023 - WBTESTHQ2	822	2	1

Service Entry Status Status Changes

- Open Repair in Progress

Dealer
052222 - ROSSOCORSA S.R.L.

Chassis no.	Plate #	Customer Name	Actual Owner
192384		GHIBLI DIESEL	Yes <input checked="" type="radio"/> No <input type="radio"/>

Repair Order# Repair order opening date Mileage In Vehicle towed in due to technical issues Loaner Car

2022346 16.03.2022 Km M 71809 Yes No Yes No

Mobility services provided Open Customer Case Rental Car

Yes No 1 selected Yes No Yes No

Fleet Vehicle

Yes No

Service Note

Back to list Check Save Vehicle Report Bulletins Knowledge on Line

管理保养条目状态

“删除”状态

要删除保养条目，请从“新状态” (New Status) 下拉菜单中选择“删除” (Delete)。删除保养条目的唯一原因可能是“插入错误：底盘号错误” (Insert mistake: Chassis # wrong)，因此这将是“原因” 字段中的唯一可用项。单击“确认” (Confirm)，删除保养条目。

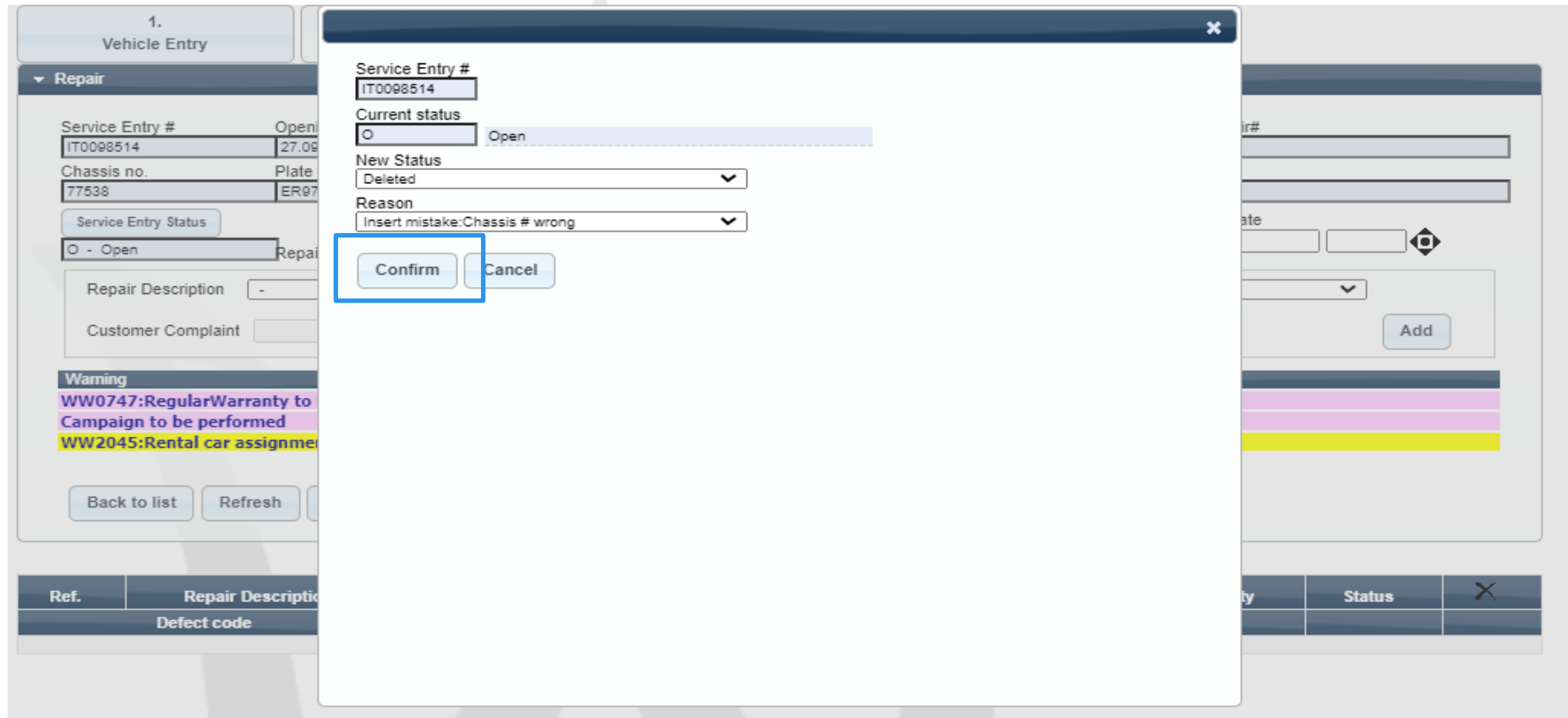

管理保养条目状态

“删除”状态

单击“确认”按钮后，保养条目中将显示新的“已删除”状态。

1. Vehicle Entry2. Repair3. Close

Vehicle Entry

Service Entry #	Opening date	Last Update	Days down	Vehicle Downtime	Previous Repair#
IT0098514	27.09.2022	24.11.2023 - WBTSTHQ2	0	52	9

Status

Status Changes

A - Deleted

Dealer

052222 - ROSSOCORSA S.R.L.

Chassis no.	Plate #	Mileage In	Customer Name	Actual Owner
77538	ER9782T	M157 V6 2WD 410HP EU	客户姓名	Yes <input type="radio"/> No <input checked="" type="radio"/>

Repair Order#	Repair order opening date	Mileage In	Vehicle towed in due to technical issues	Loaner Car
2143243	01.09.2023	Km <input checked="" type="radio"/> M <input type="radio"/> 90000	Yes <input type="radio"/> No <input checked="" type="radio"/>	Yes <input type="radio"/> No <input checked="" type="radio"/>

Mobility services provided

Yes No 1 selected

Open Customer Case

Yes No

Rental Car

Yes No

Service Note

Back to list Vehicle Report Bulletins Knowledge on Line

Warning



如果输入了 BOL 或保修索赔，或者保养条目已经关闭，则不能删除保养条目。

如果必须删除保养条目，请联系您的 ABM 进行案例评估。

管理保养条目状态

“维修暂停” 状态

如果维修中断，必须立即为相关保养条目设置“维修暂停”状态，并说明导致作业暂停的问题类型。当出现以下至少一种情况时，保养条目的状态可以从“已打开”更改为“维修暂停”：等待备件；等待技术支持；转租进行中；等待授权；等待车辆交付。



导致作业暂停的问题得到解决后，保养条目状态必须立即从“维修暂停”更改为“已打开”，除非已经进行了特定自动检查，例如“维修暂停 - 等待备件”状态。

The screenshot shows a software interface for managing vehicle repairs. A modal window is open for editing a service entry. The 'Current status' is 'Open' and the 'New Status' is set to 'Repair on Hold'. A dropdown menu for 'Reason' is open, showing options: 'Waiting parts', 'Waiting for Tech. support', 'Sublet', 'Waiting for Authorization', and 'Waiting for vehicle delivery'. The background shows a 'Vehicle Entry' form with fields for Service Entry #, Chassis no., and Repair Description.

管理保养条目状态

维修暂停 - 等待备件

当仓库中没有进行维修所需的一个或多个备件时，可以设置该种状态。

从“新状态” (New status) 菜单中选择“维修暂停” (Repair on hold)，从“原因” (Reason) 菜单中选择“等待备件” (Waiting parts) 后，即自动显示与 VIN 相关的订单列表。

Order	Order date	Total lines of parts order	Total lines selected	Select Spare parts
18281	04/09/2015	2	0	
18301	04/09/2015	1	0	
18304	04/09/2015	2	1	
18447	04/09/2015	1	0	
18563	04/09/2015	2	0	



仅适用于进口商：

当为相关保养条目 VIN 输入一个或多个 VOR 订单时，保养条目的状态将自动从“已打开”更改为“维修暂停 - 等待备件”

管理保养条目状态

维修暂停 - 等待备件

在包含不可用备件的订单所对应的行中，单击“选择备件” (Select Spare parts) 按钮。

The screenshot shows a software interface for managing vehicle repairs. A modal dialog box titled "Select Spare parts" is open, displaying a table of spare parts orders. The table has the following data:

Order	Order date	Total lines of parts order	Total lines selected	Select Spare parts
18281	04/09/2015	2	0	▶
18301	04/09/2015	1	0	▶
18304	04/09/2015	2	1	▶
18447	04/09/2015	1	0	▶
18563	04/09/2015	2	0	▶

The play button icon in the second row (Order 18301) is highlighted with a blue box, indicating it is the target for selection.



- 进口商/子公司可以使用进口商零件订单号暂停自己的保养条目
- 进口商/子公司可以使用子网络零件订单号暂停其子网络的保养条目
- 子网络可以使用自己的零件订单号暂停自己的保养条目

管理保养条目状态

维修暂停 - 等待备件

从列表中选择不可用备件，然后单击“保存” (Save)。如果订单号不在订单列表中，则需要手动将其插入“备件订单参考” (Spare parts order reference) 字段。

The screenshot displays a software interface for managing vehicle repairs. A modal dialog box is open, titled '1. Vehicle Entry'. It contains the following information:

- Service Entry #: 48121
- Order: 18563
- Order date: 04/09/2015
- Total lines of parts order: 2
- Total lines selected: 1

Row	Chassis #	Part Code	Description	Waiting
2	94229	920002240	WHEEL SECURITY STUD BOLT KIT	<input type="checkbox"/>
1	94229	940000275	USA BATTERY CHARGER AND MANTAI	<input checked="" type="checkbox"/>

At the bottom of the dialog, there is a 'Save' button highlighted with a red box. Below the dialog, a yellow banner indicates '1 rows selected in waiting'. The background interface shows a 'Repair' section with fields for Service Entry # (US0048121), Chassis # (94229), and Service Entry Status (Open). A table below shows a repair description '01 - Anomaly'.



您需要填写所需字段以正确设置该状态，特别是输入订单号，以便给为故障车辆输入的订单分配正确的优先级。

管理保养条目状态

维修暂停 - 等待备件

- 设置“维修暂停 - 等待备件”状态后，相关 Maserati 员工和经销商经理即会收到电子邮件通知（应其所求）。
- Maserati 日常监控处于“维修暂停 - 等待备件”状态的保养条目，采取一切必要措施尽快运送不可用部件，以保证为最终客户提供正确的服务水平。
- 保养条目状态将保持为“维修暂停 - 等待备件”，直到到达最后一个订单的发票日期和预计平均交付时间。该段时间过后，保养条目即自动返回到“已打开”状态。您的 ABM 可以为您的市场提供更具体的信息。



如果您需要接收与部件保养条目“暂停 - 等待备件”相关的警告消息，请与您的
ABM 联系



管理保养条目状态

维修暂停 - 等待技术支持

根据有关 Blue On Line 政策的通函中规定的政策，在等待 Maserati 服务台反馈时，如果打开 Blue On Line 请求，则自动设置该“暂停”状态。

- 从“已打开”状态自动切换到“暂停 - 等待技术支持”状态可确保尽可能准确地反映实际诊断和维修状态，如果保养条目中至少有一个状态为“索赔已确认”、“第二次提交”、“正在分析”或“工厂升级”的 Blue On Line 请求打开，则将自动切换状态。

重要提示：

- 如果保养条目由于其他原因已经处于“暂停”或“已关闭”状态，则自动切换不适用。
 - 在激活该状态所需的条件不再存在，并且在上述状态下 Maserati 仍管理至少一个 BOL 的情况下，只有当保养条目状态最初为“暂停- 等待备件”，才会自动设置“暂停- 等待技术支持”。
- 如果保养条目中的所有 Blue On Line 请求都处于以下状态之一，则“暂停 - 等待技术支持”状态将自动切换为“已打开”：“正在等待经销商提供信息” / “已拒绝” / “已取消” / “已关闭”。
- ### 重要提示：
- 自动切换不适用于以下情况：*
- 保养条目因其他原因已处于“暂停”状态
 - 同时，您已手动关闭保养条目
- 设置该状态后，相关 Maserati 员工和经销商经理即会收到电子邮件通知（应其所求）。

管理保养条目状态

维修暂停 - 转租进行中

- 当专业外部维修正在进行时，必须设置该状态，表明车辆已暂时离开经销商车间。

要设置该状态，必须指定对车辆执行的外部干预类型，从以下可用选项中进行选择：

- 车身维修
- 专门维修：机械
- 专门维修：电气
- 车身内部专门维修

The screenshot displays a software interface for managing vehicle repairs. The main window is titled '1. Vehicle Entry' and contains a 'Repair' section. The 'Repair' section includes fields for 'Service Entry #' (IT0098889), 'Open' date (16.03), 'Chassis no.' (192384), and 'Plate' (FG08). Below these fields are buttons for 'Service Entry Status' and 'Repair Description'. A 'Warning' section contains two lines of text: 'WW0747:RegularWarranty to' and 'WW2045:Rental car assignme'. At the bottom of the main window are 'Back to list' and 'Refresh' buttons. A modal window is open over the 'Repair' section, showing the 'Service Entry #' (IT0098889), 'Current status' (Open), and 'New Status' (Repair on Hold). The 'Reason' is set to 'Sublet' and the 'Sublet' dropdown menu is open, showing options: 'Bodyshop work', 'Special repair: mechanical', 'Special repair: electrical', and 'Body Interiors specific repair'. The modal window also has a close button (X) in the top right corner.

管理保养条目状态

维修暂停 - 等待授权

- 在等待授权以继续进行作业时，可以选择此“维修暂停”状态类型。

要设置该状态，必须选择以下选项之一：

一：

- 等待客户
- 报价确认
- 法律/保险原因
- 其他

如果选择了所列选项之一，则必须在“说明” (Notes) 字段中输入案例的简要描述。证明文件的参考资料（如有）必须包括在内。

The screenshot displays a software interface for managing vehicle repairs. On the left, a 'Repair' entry is shown with details: Service Entry # IT0096689, Open date 16.03, Chassis no. 192384, and Plate FG08. Below this, there are fields for 'Service Entry Status' (set to 'O - Open'), 'Repair Description', and 'Customer Complaint'. A 'Warning' section contains two items: 'WW0747:RegularWarranty to' and 'WW2045:Rental car assignme'. At the bottom, a table lists repair entries with columns for 'Ref.' and 'Repair Description'. The main part of the screenshot is a dialog box for editing the 'Service Entry #'. It shows the current status as 'Open' and allows selecting a 'New Status' (currently 'Repair on Hold') and a 'Reason' (currently 'Waiting for Authorization'). A dropdown menu for 'Reason pending authorization' is open, showing options: 'Waiting for Customer', 'Confirmation of Proforma Inv.', 'Legal/insurance Reasons', and 'Other'. A pink highlighted instruction reads 'Please, Detail the case and indicate eventual documents codes'. Below the dialog, a 'Note' field is visible with the same pink instruction. An arrow points from the 'Reason pending authorization' dropdown to the 'Note' field.

Ref.	Repair Description
	Defect code
2	Anomaly
36	SEIZURE-STIFFNESS
3	Anomaly

管理保养条目状态

维修暂停 - 等待车辆交付

- 该“维修暂停”状态类型只能在客户出于正当理由延迟取走已修好的车辆，因此无法在维修结束后立即关闭工单和保养条目的情况下设置。

The screenshot displays a software interface for managing vehicle repairs. On the left, a 'Vehicle Entry' form shows details for a repair with Service Entry # CL0000800, Chassis no. 424892, and Plate NA. The current status is 'Open'. A modal window is open over this entry, allowing the user to change the 'New Status' to 'Repair on Hold' and select a 'Reason' from a dropdown menu. The 'Reason' dropdown is currently open, showing options: 'Waiting parts', 'Waiting for Tech. support', 'Sublet', 'Waiting for Authorization', and 'Waiting for vehicle delivery' (which is highlighted in blue). Below the modal, a table lists repair descriptions and defect codes.

Ref.	Repair Description
	Defect code
1	Anomaly
25	- NOT PROPERLY WORKING / FAILURE

管理保养条目状态

自动发送消息

- 已经引入自动发送警告消息功能，以避免因车辆正在车间进行维修这一不合理的理由而导致保养条目关闭延迟。
- 这些消息仅在保养条目处于以下状态之一时，在保养条目打开后的第三个工作日后（东盟市场为第二个工作日后）通过电子邮件发送：
 - 打开
 - 暂停 - 外部维修
 - 暂停 - 等待授权
 - 暂停 - 等待车辆交付
- 如果在收到该通知后保养条目仍未关闭，我们将每 3 个工作日（东盟市场为每 2 个工作日）发送一封电子邮件作为提醒。
- 这些警报有助于更好地共享车间内现有车辆的信息，以及识别需要 Maserati 及时处理的案例。

这些信息也可见于通函 MAS003513 “保养条目管理：新的‘暂停 - 等待技术支持’状态的自动切换和车辆故障天数警报”。



保养条目连接功能

保养条目连接功能

激活流程

当联网车辆未订阅时，“车辆条目” (Vehicle Entry) 工作表中央会显示一条信息性消息：“该车没有激活“Maserati 互联”订阅。客户符合登记条件” (There is no Maserati Connect active subscription for this vehicle. Customer is eligible for the registration process)。要继续激活，请单击“Maserati 互联” (Maserati Connect)”选项卡。

Service Note

Yes No

Back to list Check Save Vehicle Report Bulletins Knowledge on Line

Warning
WW0370: No Open Campaigns for this vehicle
One or more Privacy consents are missing. Please present our Policy to the customer and request consents.
There is no Maserati Connect active subscription for this vehicle. Customer is eligible for the registration process.

Vehicle Information Campaign Warranty BOL Vehicle Configuration Update Service Entry Customer Data **Maserati Connect**

Subscription

ID Gigya

Status Activation Date

Subscriber

First Name Last Name Phone Number

Country E-Mail Status

New Subscription



此处描述的连接功能仅适用于特定市场！

保养条目连接功能

激活流程

然后单击“新订阅” (New Subscription) 按钮，打开激活窗口。

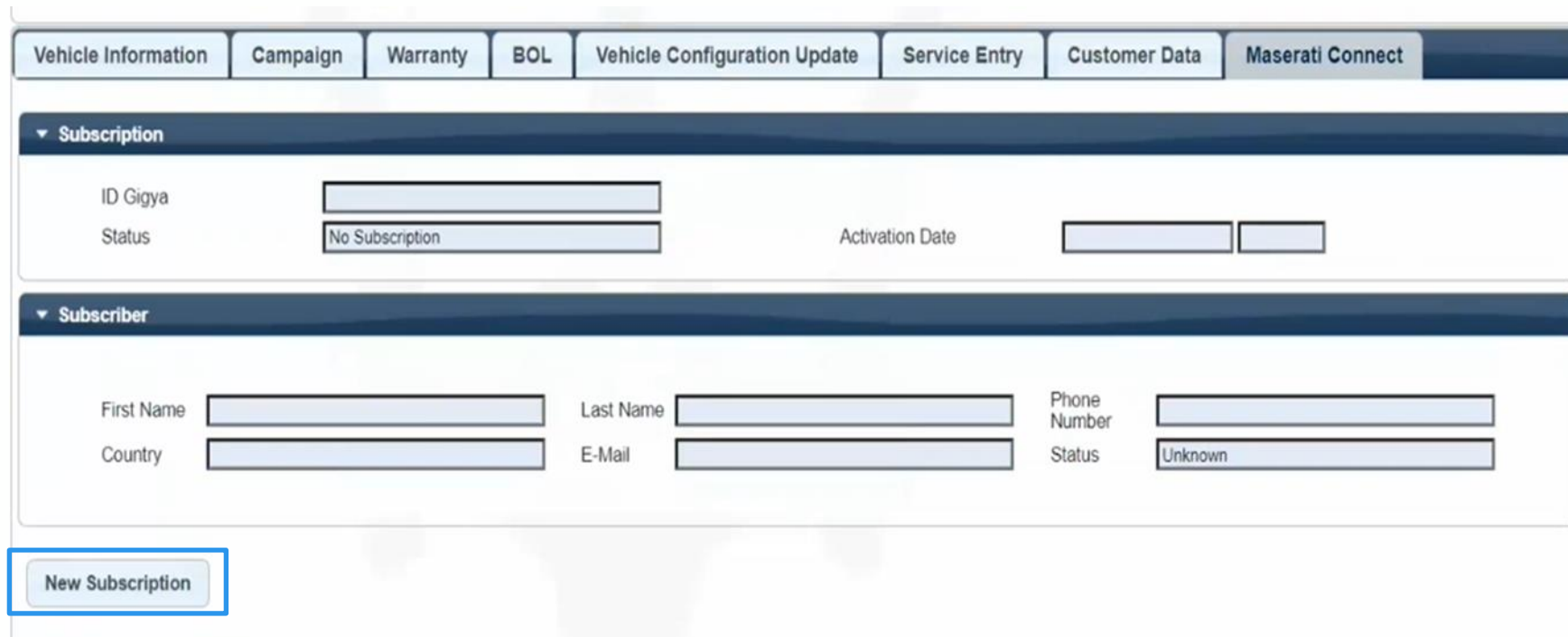

The screenshot displays a web interface with a navigation bar at the top containing the following tabs: Vehicle Information, Campaign, Warranty, BOL, Vehicle Configuration Update, Service Entry, Customer Data, and Maserati Connect. Below the navigation bar, there are two main sections:

- Subscription Section:** Contains fields for ID Giga (input), Status (No Subscription), and Activation Date (two input fields).
- Subscriber Section:** Contains fields for First Name, Last Name, Phone Number, Country, E-Mail, and Status (Unknown).

A button labeled "New Subscription" is located at the bottom left of the form area and is highlighted with a blue border.

保养条目连接功能

激活流程

填写订户数据。也可以使用“从客户复制” (Copy from Customer) 按钮复制客户数据，将自动填写姓名和电子邮件字段。要继续保存，必须填写所有必填字段。然后单击“保存并发送” (Save and send) 按钮并关闭窗口。

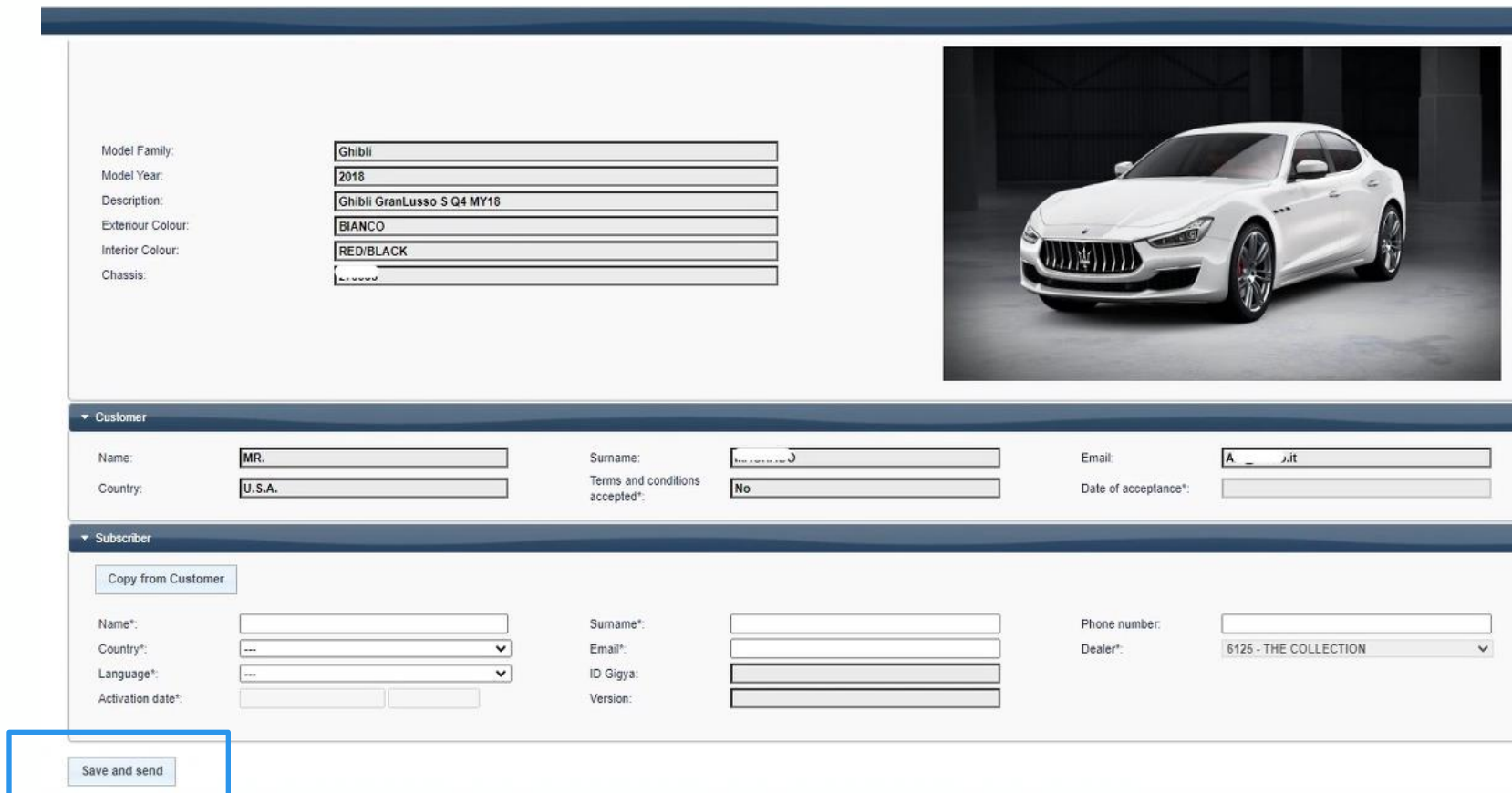

Model Family:	Ghibli
Model Year:	2018
Description:	Ghibli GranLusso S Q4 MY18
Exterior Colour:	BIANCO
Interior Colour:	RED/BLACK
Chassis:	



Customer

Name:	MR.	Surname:		Email:	A. Jit
Country:	U.S.A.	Terms and conditions accepted*:	No	Date of acceptance*:	

Subscriber

Copy from Customer

Name*:		Surname*:		Phone number:	
Country*:	---	Email*:		Dealer*:	6125 - THE COLLECTION
Language*:	---	ID Gigya:			
Activation date*:		Version:			

Save and send

注意:

国家/地区是指车辆的第一个销售市场。可用语言仅指为所选国家/地区配置的语言。

保养条目连接功能

激活流程

现在，您可以在“订阅” (Subscription) 部分中找到所有插入的数据。订阅状态为“待订阅” (Subscription Pending)。

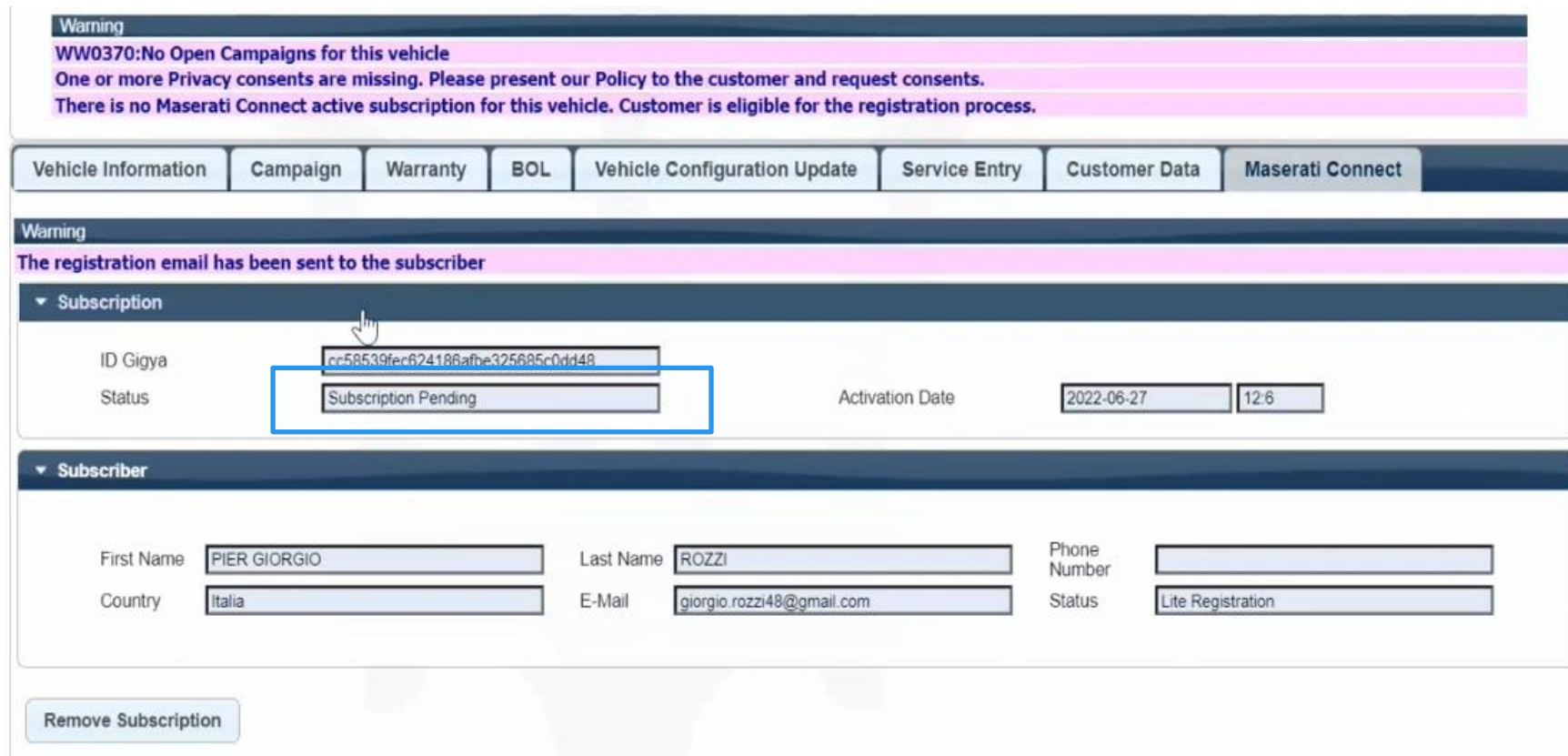

The screenshot displays the Maserati Connect interface. At the top, a warning message states: "Warning WW0370: No Open Campaigns for this vehicle. One or more Privacy consents are missing. Please present our Policy to the customer and request consents. There is no Maserati Connect active subscription for this vehicle. Customer is eligible for the registration process." Below this, a navigation bar includes tabs for "Vehicle Information", "Campaign", "Warranty", "BOL", "Vehicle Configuration Update", "Service Entry", "Customer Data", and "Maserati Connect". The "Maserati Connect" tab is active, showing a warning: "The registration email has been sent to the subscriber". Under the "Subscription" section, the "ID Gigya" is "cc58539fec624186afbe325685c0dd48" and the "Status" is "Subscription Pending", which is highlighted with a blue box. The "Activation Date" is "2022-06-27" with a "12.6" value next to it. The "Subscriber" section shows "First Name" as "PIER GIORGIO", "Last Name" as "ROZZI", "Country" as "Italia", "E-Mail" as "giorgio.rozzi48@gmail.com", and "Status" as "Lite Registration". A "Remove Subscription" button is located at the bottom left.

Warning	
WW0370: No Open Campaigns for this vehicle	
One or more Privacy consents are missing. Please present our Policy to the customer and request consents.	
There is no Maserati Connect active subscription for this vehicle. Customer is eligible for the registration process.	

Warning	
The registration email has been sent to the subscriber	

Subscription	
ID Gigya	cc58539fec624186afbe325685c0dd48
Status	Subscription Pending
Activation Date	2022-06-27 12.6

Subscriber					
First Name	PIER GIORGIO	Last Name	ROZZI	Phone Number	
Country	Italia	E-Mail	giorgio.rozzi48@gmail.com	Status	Lite Registration

Remove Subscription

保养条目连接功能

激活流程

如果输入的数据正确，将向输入的电子邮件地址发送一封电子邮件，然后要求客户激活连接的服务。如果电子邮件不正确，则需要继续“返回新订阅”流程。



Maserati Connect: il lusso del pieno controllo

Gentile PAolo,

la tua GRECALE è dotata delle più recenti tecnologie, concepite per offrirti nuove esperienze digitali e connesse per tutta la vita utile dell'auto.

Scopri di più: bastano pochi clic!

[GUARDA IL VIDEO](#)

Per maggiori informazioni, ti invitiamo a [scaricare la nostra Guida](#).

Fai clic sul link sottostante e crea il tuo account sul sito web di **Maserati Connect** per iniziare a godere dell'esperienza **Maserati Connect**.

[INIZIA ORA](#)

Maserati Connect: il lusso del pieno controllo, sempre e ovunque.

Cordiali saluti,
Il Team Maserati

保养条目连接功能

激活流程

当客户完成登记流程所需的所有步骤时，“状态” (Status) 将设置为“订阅激活” (Subscription Active)。

Vehicle Information	Campaign	Warranty	BOL	Change of Ownership	Vehicle Configuration Update	Service Entry	Customer Data
Dossier list	Maserati Connect						
Warning							
The registration process has been completed							
▼ Subscription							
ID Gigya	562e6bb3d223455fbee7ba89809cab15						
Status	Subscription Active			Activation Date	2022-06-24	14:33	
▼ Subscriber							
First Name	Sara	Last Name	Candelmo	Phone Number			
Country	Italia	E-Mail	sara.candelmo@accenture.com	Status	Full Registration		
Remove Subscription							

保养条目连接功能

“返回新订阅” 流程

要将车辆恢复为默认模式（例如，车辆转让、车辆已报废、车辆已售等），请单击“车辆条目” (Vehicle Entry) 工作表中的“Maserati 互联” (Maserati Connect)” 选项卡。

The screenshot displays the 'Vehicle Entry' form in the Maserati Connect system. At the top, there are three buttons: '1. Vehicle Entry', '2. Repair', and '3. Close'. Below this, the 'Vehicle Entry' section contains various fields for service entry details, including 'Service Entry #', 'Opening date', 'Last Update', 'Days down', 'Vehicle Downtime', and 'Previous Repair#'. A 'Service Entry Status' dropdown is set to 'Open', and the 'Dealer' is '006126 - THE COLLECTION, LLC'. The vehicle is identified as a 'LEVANTE' with a 'Mileage In' of 153000. There are several radio buttons for 'Actual Owner', 'Vehicle towed in due to technical issues', 'Loaner Car', and 'Open Customer Case'. A 'Service Note' field is present below these options. At the bottom of the form, there are buttons for 'Back to list', 'Check', 'Save', 'Vehicle Report', 'Bulletins', and 'Knowledge on Line'. A warning message 'WW0370: No Open Campaigns for this vehicle' is displayed in a pink banner. Below the form, a navigation bar includes tabs for 'Vehicle Information', 'Campaign', 'Warranty', 'BOL', 'Vehicle Configuration Update', 'Service Entry', 'Customer Data', and 'Maserati Connect', which is highlighted with a blue box. The 'Maserati Connect' tab is active, showing a detailed view of the vehicle's specifications, including 'Vehicle Information', 'Finish', 'Option List', and 'Warranty'.

Service Entry #	Opening date	Last Update	Days down	Vehicle Downtime	Previous Repair#
US0528075	05/24/2022	05/24/2022		18	7

Service Entry Status	Repair in Progress
<input type="radio"/> Open	<input type="radio"/> Repair in Progress

Chassis no.	Plate #	Customer Name	Actual Owner
	LEVANTE		<input checked="" type="radio"/> Yes <input type="radio"/> No

Repair Order#	Repair order opening date	Mileage In	Vehicle towed in due to technical issues	Loaner Car
153	05/24/2022	Km <input type="radio"/> M <input checked="" type="radio"/> 153000	<input type="radio"/> Yes <input checked="" type="radio"/> No	<input type="radio"/> Yes <input checked="" type="radio"/> No

Open Customer Case
<input type="radio"/> Yes <input checked="" type="radio"/> No

Vehicle Information	Campaign	Warranty	BOL	Vehicle Configuration Update	Service Entry	Customer Data	Maserati Connect
Vehicle Information Chassis no. [REDACTED] Vehicle [REDACTED] 3.0 BT V6 4WD 350HP GS USA E V.I.N. [REDACTED] Assembly # [REDACTED] Model Year 2019 PDI Status Marketing Card Finishing date 03/12/2019 Arrival Date 04/11/2019 Engine Type Number M156D [REDACTED] Gearbox [REDACTED] Ing. key M0506 Immo Code 6520 Sales Country U.S.A. Tyre DOT 3 6VXKD7472618 Tyre DOT 4 6VXKD7472618 Tyre DOT 2 6VXKD7472618 Wheel Size N/A Tyre DOT 1 6VXKD7472618 Radio Srt# T00BE038990020 Warranty Services Type Start Date End Date Warranty 01/11/2020 01/11/2024 P- PREMIUM PLUS 3 SERVICES LEV US 01/11/2020 01/11/2023							

Finish
External Color 94084202 GRIGIO
Internal Color 94084352 BLACK/GREY
Carpets 94084338 BLACK/BLACK/GREY

Option List	
Code	Colour Code
DASH UPPER DASH & CLUSTER BROW	094084338 BLACK/BLACK/GREY
KDFT DEFAULT COMPLEMENTARY OPT.LE	
KMBC Brake STD Calipers	
QRF9 Dark Mirror Interior Trim	
QSJA Highway Assist	
QSJB Traffic Sign Recognition (TSR)	
Q0FJ License Plate Predisposition	
Q1AT Nerissimo Pack	
Q10C Driver Assistance Pack	
Q108 20" Nereo Miron Dark Grey	
Q210 Metallic Paint	
Q320 Leather Steering Wheel	
Q40J Home Link	
Q559 Ventilated Front Seats	
Q727 Full Natural Drilled Leather	
Q93P Climate Pack	
Q94J Premium Pack	
RO02 HEADLINER & PILLARS	094084295 BLACK
ST1VH STEERING WHEEL & SHIFTER	094084351 BLACK/BLACK

Vehicle Configuration Update		
Replacement date	Part Number	Number

保养条目连接功能

“返回新订阅”流程

如果车辆有关联订户，请单击“删除订阅” (Remove Subscription) 按钮，开始“返回新订阅”流程。

“返回新订阅”流程的影响包括：

- 清除用户对车辆的个人设置、配置和购买
- 取消用户对任何“Maserati 互联”服务的订阅
- 关联帐户与 VIN 解绑
- 保持车辆中安装的固件更新
- 为预装应用程序保留静态应用程序内容。其中不包含任何用户特定数据。

The screenshot displays the Maserati Connect web interface. At the top, there is a navigation bar with tabs for 'Vehicle Information', 'Campaign', 'Warranty', 'BOL', 'Change of Ownership', 'Vehicle Configuration Update', 'Service Entry', and 'Customer Data'. Below this, there are sub-tabs for 'Dossier list' and 'Maserati Connect'. A warning message states 'The registration process has been completed'. The 'Subscription' section shows details for 'ID Gigya' (562e6bb3d223455fbee7ba89809cab15), 'Status' (Subscription Active), and 'Activation Date' (2022-06-24 14:33). The 'Subscriber' section shows 'First Name' (Sara), 'Last Name' (Candelmo), 'Country' (Italia), 'E-Mail' (sara.candelmo@accenture.com), and 'Status' (Full Registration). A 'Remove Subscription' button is highlighted with a blue box at the bottom left.

Subscription	
ID Gigya	562e6bb3d223455fbee7ba89809cab15
Status	Subscription Active
Activation Date	2022-06-24 14:33

Subscriber					
First Name	Sara	Last Name	Candelmo	Phone Number	
Country	Italia	E-Mail	sara.candelmo@accenture.com	Status	Full Registration

保养条目连接功能

“返回新订阅”流程

单击“删除车辆” (Remove vehicle) 按钮完成操作。

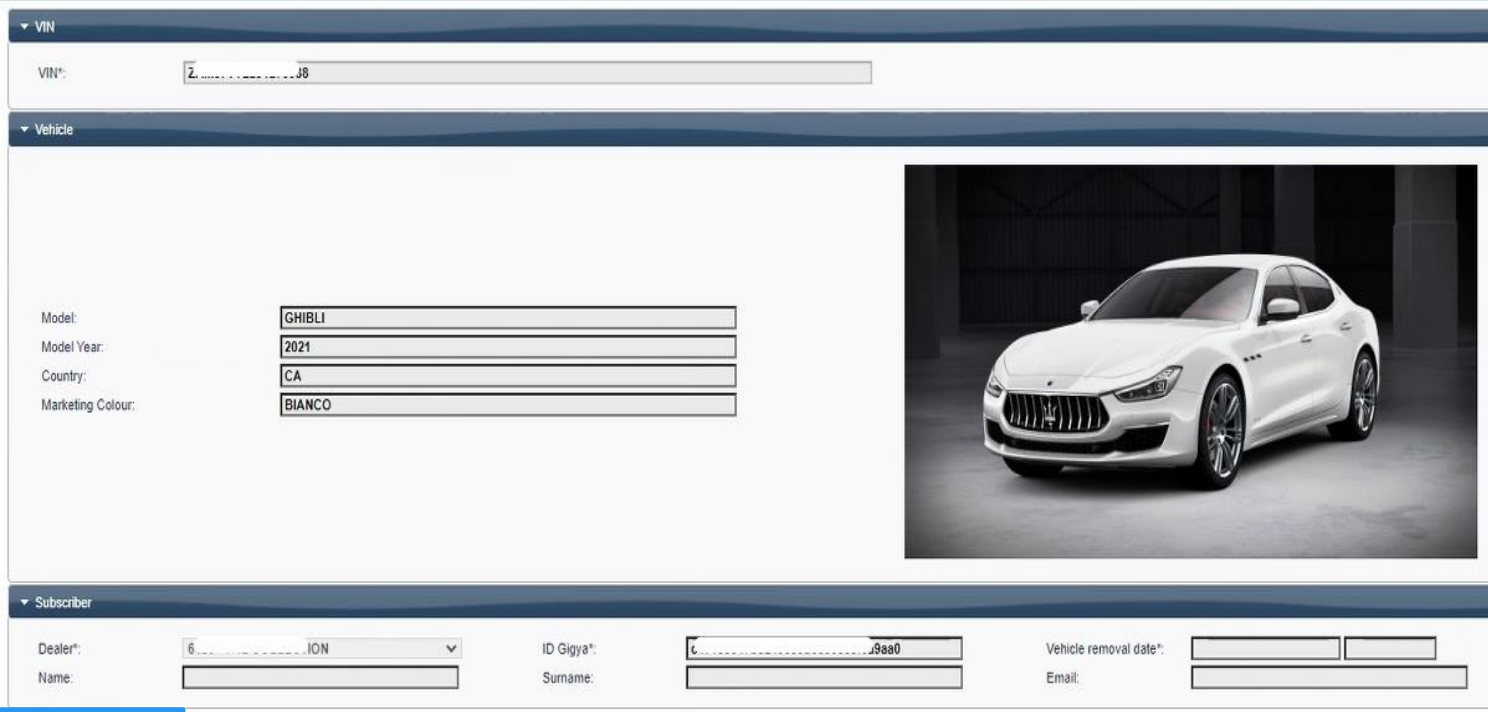

▼ VIN

VIN*: Z.....J8

▼ Vehicle

Model: GHIBLI

Model Year: 2021

Country: CA

Marketing Colour: BIANCO



▼ Subscriber

Dealer*: 6.....ION

ID Giglia*:9aa0

Vehicle removal date*:

Name:

Surname:

Email:

Remove vehicle

保养条目连接功能

“返回新订阅”流程

关闭确认弹出窗口和该窗口。订阅状态为“无订阅”(No Subscription)。如果需要，您现在可以激活新订户。

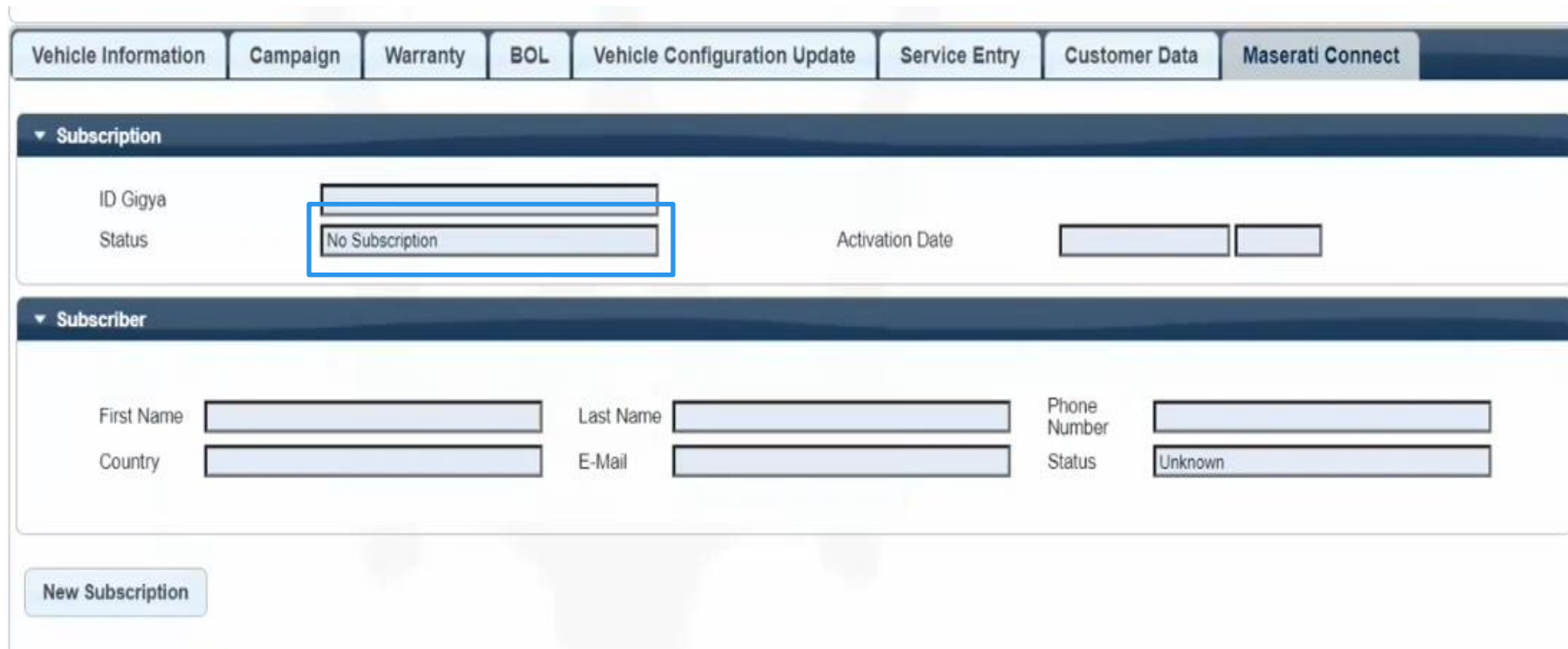

The screenshot displays the Maserati Connect interface with the following elements:

- Navigation Bar:** Vehicle Information, Campaign, Warranty, BOL, Vehicle Configuration Update, Service Entry, Customer Data, Maserati Connect.
- Subscription Section:**
 - ID Gigya: [Input Field]
 - Status: **No Subscription** (highlighted with a blue box)
 - Activation Date: [Input Field] [Input Field]
- Subscriber Section:**
 - First Name: [Input Field]
 - Last Name: [Input Field]
 - Phone Number: [Input Field]
 - Country: [Input Field]
 - E-Mail: [Input Field]
 - Status: Unknown
- Buttons:** New Subscription

有关保养条目连接功能的更多详细信息，请参阅通函 MAS003242 “保养条目中的新连接功能” 和随附的手册。



更换车辆管理

更换车辆管理

代步车：分配

要输入信息并要求赔付代步车费用，请在“提供的移动服务” (Mobility services provided) 功能的可用选项中选择“Maserati 代步车” (Maserati loaner car)，然后在“车辆条目” (Vehicle Entry) 工作表中选择“代步车” (Loaner Car) = “是” (Yes) 单选按钮。单击“保存” (Save) 后，将出现一个新的“代步车” (Loaner Car) 选项卡。

The screenshot displays the 'Vehicle Entry' form with the following details:

- Navigation:** 1. Vehicle Entry, 2. Repair, 3. Close
- Warnings:** WW0221: Mileage > Km 150000; WW0261: This car covers on average over 100 km per day
- Table:**

Service Entry #	Opening date	Last Update	Days down	Vehicle Downtime	Previous Repair#
IT0098594	08.10.2023	27.11.2023 - WBTESTHQ2	53	2	4
- Service Entry Status:** Open (selected), Repair in Progress
- Dealer:** 052222 - ROSSOCORSA S.R.L.
- Vehicle Info:** Chassis no. 392207, Plate # rrddd44, LEVANTE HYBRID, Customer Name, Actual Owner (Yes/No/N/A)
- Repair Order:** 89561, Repair order opening date 06.10.2023, Mileage In 150009 Km
- Mobility services provided:** Yes (selected), No
- Service Note:** (Empty text area)
- Buttons:** Back to list, Check, Save, Vehicle Report, In Line
- Dropdown Menu:** 1 selected, Maserati Loaner Car (checked), Another brand loaner car, Rental Car, Public Transportation, Pick up & delivery
- Additional Options:** Vehicle towed in due to technical issues (Yes/No), Open Customer Case (Yes/No), Loaner Car (Yes/No), Rental Car (Yes/No)
- Bottom Bar:** Vehicle Information, Campaign, Warranty, BOL, Vehicle Configuration Update, Service Entry, **Loaner Car** (highlighted), Maserati Connect, Maintenance
- Footer:** Vehicle Information, Finish



代步车的相关功能仅适用于特定市场！

请记住，根据 Maserati 政策，您只能要求赔付 Maserati 代步车费用。

更换车辆管理

代步车：分配

单击“代步车” (Loaner Car) 按钮，您将进入相关工作表，在此您可以输入与所提供的 Maserati 代步车相关的信息。

在“代步车”工作表中，您可以：

- 1.单击“添加” (Add) 按钮，分配代步车。
- 2.单击“先前分配” (Previous Assignment) 按钮，查看分配历史记录。

1. Vehicle Entry 2. Repair 3. Close

Vehicle Entry

Vehicle Information Campaign Warranty BOL Vehicle Configuration Update Service Entry **Loaner Car** Maserati Connect Maintenance

Assigned Vehicle				
VIN	Model	Mileage	Assignment Date	Maint
No data available in table				

Add Previous Assignments

更换车辆管理

代步车：分配

单击“先前分配” (Previous Assignment) 按钮，将出现一个弹出窗口，其中包含先前分配的所有详细信息。

The screenshot displays the 'Loaner Car' management interface. At the top, there are three main steps: 1. Vehicle Entry, 2. Repair, and 3. Close. Below this, a navigation bar includes 'Vehicle Entry', 'Vehicle Information', 'Campaign', 'Warranty', 'BOL', 'Vehicle Configuration Update', 'Service Entry', 'Loaner Car' (highlighted with a blue box), 'Maserati Connect', and 'Maintenance'. The main content area shows an 'Assigned Vehicle' table with columns for VIN, Model, Mileage, Assignment Date, and Maint. Below this table are 'Add' and 'Previous Assignments' buttons. An arrow points from the 'Previous Assignments' button to a popup window titled 'Previous Assignments'. This popup window contains a table with columns for VIN, Model, From, and To, listing several vehicle assignments.

Assigned Vehicle				
VIN	Model	Mileage	Assignment Date	Maint
No data available in table				

Previous Assignments				
VIN	Model	From	To	
ZN6TU61B00X299464		16.10.2018	16.10.2018	
ZN00U61B00X274782	00044	17.10.2018	17.10.2018	
ZAMTS57B001188142	GH275R 16	17.10.2018	17.10.2018	
ZAMTS57B001188142	GH275R 16	17.10.2018	17.10.2018	
ZAMTP56B001125828	QP275R 15	17.10.2018	17.10.2018	

更换车辆管理

代步车：分配

单击“添加” (Add) 按钮，系统将显示一个弹出窗口，您可在此搜索“代步车控制台”功能上可用的 Maserati 汽车。

Loaner Car Assignment

▼ Filtri

Brand

Search

	Brand	Model Year	Model	VIN	Usage Start Date	Seniority Car	Km / M	Service Entry #
<input type="radio"/>	MASERATI	2011	QP47GTSAW - Quattroporte 4.7 GTS AWARDS ED	ZAMKK39B000055669	05.11.2018 - 14:19	2875 Days	11 Km	
<input type="radio"/>	MASERATI	2014	GH410A 14 - Ghibli S Q4 MY14	ZAMRT57B001125259	19.10.2018 - 17:14	1419 Days	6 Km	
<input type="radio"/>	MASERATI	2016	GH275R 16 - GH275R 16	ZAMTS57B001188142	05.11.2018 - 17:57	110 Days	7 Km	
<input type="radio"/>	MASERATI	2014	GT47CC 14 - GranTurismo Sport CC MY14	ZAMUH45B000090966	05.11.2018 - 14:49	1510 Days	10 Km	
<input type="radio"/>	MASERATI	2014	GH250R 14 - Ghibli Diesel 250Hp MY14	ZAMWS57B001080771	04.11.2018 - 11:28	1790 Days	27 Km	

↻ | << | Pagina 1 | di 1 | >> | 10 ▼

Mileage Out

Add Close

更换车辆管理

代步车：分配

要将车辆分配给客户，您必须：

- 1.选择可用车辆（尚未分配给其他客户）
- 2.插入所选车辆的出站里程。
- 3.单击“添加” (Add) 按钮。

Loaner Car Assignment

Brand: Maserati

Search

	Brand	Model Year	Model	VIN	Usage Start Date	Seniority Car	Km / M	Service Entry #
1	MASERATI	2015	QP275R 15 - Quattroporte Diesel MY15	ZAMTP56B001125828	11.10.2018 - 14:15	1139 Days	13000 Km	
	MASERATI	2016	GH275R 16 - GH275R 16	ZAMTS57B001188142	19.07.2018 - 11:08	90 Days	0 Km	
	MASERATI	2018	-	ZN6TU61B00X299464	08.10.2018 - 11:30	0	10 Km	
	MASERATI	2018	-	ZN6TU61B00X299465	08.10.2018 - 11:32	0	10 Km	

Mileage Out: 13001

2

3 Add Close



已分配给其他客户或涉及维修干预/保养条目（例如：针对代步车保养/维修）的代步车不能被选择进行进一步分配，除非该车再次准备就绪（相关保养条目已关闭）。

Maserati 预计无法赔付的代步车不能分配给客户。系统将显示一条错误消息。因此，如果必须选择/分配其他车辆（例如，演示车），请联系 ABM。

更换车辆管理

代步车：分配

分配代步车后，即可单击“先前分配” (Previous Assignments) 按钮，在同一保养条目上查看当前分配的车辆和过去分配的任何其他车辆。

The screenshot displays a software interface for vehicle management. At the top, there are several tabs: Vehicle Information, Campaign, Warranty, BOL, Vehicle Configuration Update, Service Entry, Customer Data, and Loaner Car. The 'Assigned Vehicle' section is highlighted with a red box and a '1' in a red circle. It contains a table with the following data:

VIN	Model	Mileage	Assignment Date	
ZAMTP56B001125828	Quattroporte Diesel MY15	10 Km	17.10.2018	X

Below this table are buttons for 'Close Assignment' and 'Mileage In' with an input field. A '2' in a red circle highlights the 'Previous Assignments' button. An arrow points from this button to a pop-up window titled 'Previous Assignments'. This window contains a table with the following data:

VIN	Model	From	To
ZN6TU61B00X299464		16.10.2018	16.10.2018
ZN00U61B00X274782	00044	17.10.2018	17.10.2018
ZAMTS57B001188142	GH275R 16	17.10.2018	17.10.2018
ZAMTS57B001188142	GH275R 16	17.10.2018	17.10.2018
ZAMTP56B001125828	QP275R 15	17.10.2018	17.10.2018

There is also a 'Back' button at the bottom of the 'Previous Assignments' window. To the right of the main interface, there is a large black circle with a white exclamation mark, and a light blue box containing the text: '在保养条目中，不能同时分配多辆车。'

更换车辆管理

代步车：分配

将车辆分配给客户会导致自动创建作业线。系统将按以下方式填写作业线：

维修说明 -> 额外服务

部件代码 -> 000100 - 替代交通工具

故障代码 -> 517 - 代步车

W/C/I -> 保修

1. Vehicle Entry
2. Repair
3. Close

▼ Repair

Service Entry #	Opening date	Last Update	Days down	Vehicle Downtime	Previous Repair#
IT0015674	04.11.2018	06.11.2018 - ITRSCA07	3	0	6
Chassis no.	Plate #		Repair Order#	Repair order opening date	Mileage In
I25644	No	GHIBLI CHN MY2014	1555932	04.11.2018	K 10000

Service Entry Status: O - Open Repair in Progress

First Punch Date:

Repair Description: Component: Defect code:

Customer Complaint: W/C/I: Add

Warning
 WW0747:RegularWarranty to be started or RepairDate less than Reg.Wty Start Date
 Vehicle with more than 10 visits in the workshop

Back to list
Refresh
Save
Bulletins
Knowledge on Line
Summary

Ref.	Repair Description	Component Code	Description	W/C/I	Activity	Status
	Defect code		Customer Complaint			
1	Additional Services	000100	ALTERNATIVE TRANSPORTATION/ADD	Warranty	Repair 1	
	517 - LOANER CAR	Loaner Car				Claim 1 Bozza

更换车辆管理

代步车：分配

系统自动创建索赔，带有与 Maserati 认可的车辆/车型赔付相对应的备件代码。

代步车分配的索赔价值由 Maserati 统一规定，其中包括 5 天的使用时间。

如果分配需要额外天数，您可以通过“代步车”功能向 ABM 发送请求。

The screenshot shows a software interface for managing repairs. At the top, there are three tabs: '1. Vehicle Entry', '2. Repair', and '3. Close'. Below these is a 'Repair' section with a table header containing 'Service Entry #', 'Opening date', 'Last Update', 'Days down', 'Vehicle Downtime', and 'Previous Repair#'. Below the table are several sections: 'INFO', 'REPAIR', 'BOL+', and 'WARRANTY'. A pink banner reads 'WW0989:Attention: Warranty in draft state'. Below this are sections for 'Time Clock [0 Element inserted]', 'Labour Code [0 Element inserted]', and 'Spare Part Replaced [1 Element inserted]'. The 'Spare Part Replaced' section is highlighted with a red border and contains a table with the following data:

Code	Description	Quantity	Amount
2019201	MASERATI GHIBLI	1	350.00

Below the table is a 'Part(s) Info' button. At the bottom of the interface are 'Upload' and 'Close' buttons.



不再允许手动插入与代步车/额外天数相关的备件代码。

如果需要进一步赔付与“额外服务”相关的费用，可以插入一个部件代码为“替代交通工具”的新作业线。

更换车辆管理

代步车：额外天数请求

对于额外天数赔付请求，您应插入一个必须由 ABM 批准的请求。

要提交请求，您必须：

- 1.指定所需额外天数；
- 2.通过插入以下“问题类型”之一来解释请求
 - 技术
 - 备件
- 3.填写必填字段：
 - 如果问题类型 = 技术，则为“Bol 编号参考” (Bol # Reference)
 - 如果问题类型 = 备件，则为“备件订单参考” (Spare parts order reference) 和/或“零件编号” (Part Number)
- 4.插入可能的注释。
- 5.单击“保存” (Save) 按钮。

Extra Days Data	
Additional Days	<input type="text"/>
Issue Type	<input type="text" value="▼"/>
Status	
BOL# Reference	<input type="text"/>
Spare parts Order Reference	<input type="text"/>
Part Number	<input type="text"/>
Note	<input type="text"/>
<input type="button" value="Send"/> <input type="button" value="Delete"/>	

更换车辆管理

代步车：额外天数请求

保存后，请求状态将为“等待授权”(Awaiting Authorization)，因此您必须等待 ABM 的反馈。

输入额外天数请求后，系统将自动在保修索赔中输入与额外天数相关的备件代码。

The screenshot shows a software interface for vehicle repair management. At the top, there are three tabs: '1. Vehicle Entry', '2. Repair', and '3. Close'. Below the tabs is a 'Repair' section with a table header: 'Service Entry #', 'Opening date', 'Last Update', 'Days down', 'Vehicle Downtime', and 'Previous Repair#'. A modal window is open, displaying a 'WARRANTY' status and a 'Time Clock' section with 'Clock In' and 'Clock Out' fields. Below that is a 'Labour Code' section with a table header: 'Code', 'Description', 'Hours', and 'Amount'. The 'Spare Part Replaced' section contains a table with two rows. The second row, 'MASERATI GHIBLI EXTRA DAYS', is highlighted with a red border. The table has columns for 'Code', 'Description', 'Quantity', and 'Amount'. At the bottom of the modal, there are 'Upload' and 'Close' buttons.

Code	Description	Quantity	Amount
2019201	MASERATI GHIBLI	1	350,00
2019202	MASERATI GHIBLI EXTRA DAYS	4	60,00



额外天数请求的插入将通过电子邮件通知 ABM。

更换车辆管理

代步车：额外天数请求

在 ABM 批准的情况下：

- 与代步车分配赔付相关的索赔价值将包括额外天数。
- 请求状态将为“已批准” (Approved)。

Extra Days Data	
Additional Days	<input type="text" value="5"/>
Issue Type	<input type="text" value="Spare Parts ▼"/>
Status	Approved
BOL# Reference	<input type="text"/>
Spare parts Order Reference	<input type="text" value="12345"/>
Part Number	<input type="text"/>
Note	<input type="text"/>
<input type="button" value="Send"/> <input type="button" value="Delete"/>	

更换车辆管理

代步车：额外天数请求

在 ABM 拒绝的情况下：

- 索赔价值将与将车辆分配给客户时预计的 5 个标准天数相关。
- 请求状态将为“已拒绝” (Rejected)。

如果 ABM 拒绝批准额外天数请求，您可以按照上述步骤提交新请求。

Extra Days Data	
Additional Days	<input type="text" value="6"/>
Issue Type	Technical ▼
Status	Rejected
BOL# Reference	<input type="text" value="abc123"/>
Spare parts Order Reference	<input type="text"/>
Part Number	<input type="text"/>
Note	<input type="text"/>
<input type="button" value="Send"/> <input type="button" value="Delete"/>	



如果请求未获批准（已拒绝或等待中），则代步车分配关闭将被拒绝。要关闭分配，额外天数请求必须为“已批准”，否则您必须删除已拒绝或等待中授权请求。

更换车辆管理

代步车：关闭分配

要关闭保养条目并发送索赔，首先必须关闭代步车的已打开分配。

要关闭分配，您必须通过“车辆条目”部分中的“代步车”工作表执行以下操作：

- 填写与礼宾车进站里程相关的“进站里程” (Mileage In) 字段。
- 单击“关闭分配” (Close assignment) 按钮。

Assigned Vehicle				
VIN	Model	Mileage	Assignment Date	
ZAMTP56B001125828	Quattroporte Diesel MY15	10 Km	17.10.2018	✘

Close Assignment Mileage In **Previous Assignments**

在确认弹出窗口中再次单击“关闭分配” (Close assignment) 按钮。

Loaner Car Management

Do you want to Close the Loaner Car Assignment?

Close Assignment **Back**



分配关闭后，不再可编辑；
如果额外天数请求处于“已拒绝”状态，
将不包括在赔付中。

更换车辆管理

代步车：关闭分配

将额外天数请求发送到 ABM 后，为关闭分配，您可以：

- 等待 ABM 批准请求。在这种情况下，请求中的可用天数可赔付。
- 删除额外天数请求（如果请求被拒绝或待处理）。在这种情况下，可以发送索赔，只要求赔付代步车费用。

分配结束后，您可以关闭保养条目，然后按照标准流程发送索赔。

Extra Days Data	
Additional Days	4
Issue Type	Spare Parts ▼
Status	Waiting for Authorization
BOL# Reference	
Spare parts Order Reference	123875
Part Number	
Note	Loaner Car
<input type="button" value="Send"/> <input type="button" value="Delete"/>	



保养条目关闭后，即不可能再分配代步车或额外天数！

更换车辆管理

代步车：关闭分配

要通过“车辆条目”工作表中的“代步车”功能删除分配，您必须单击“删除分配”(Delete assignment) 按钮。

Assigned Vehicle				
VIN	Model	Mileage	Assignment Date	
ZAMTP56B001125828	Quattroporte Diesel MY15	10 Km	17.10.2018	

Mileage In

然后在系统显示的弹出窗口中确认选择。

Loaner Car Management ✕

Do you want to Delete the Loaner Car Assignment?



删除分配也将删除插入/批准的故意索赔和额外天数请求。

更换车辆管理

租赁车辆：标准天数分配

要输入向客户提供的租赁车辆信息，请在“提供的移动服务” (Mobility services provided) 功能的可用选项中选择“租赁车辆” (Rental Car)，然后在“车辆条目” (Vehicle Entry) 工作表中选择“租赁车辆” (Rental Car) = “是” (Yes) 单选按钮。单击“保存” (Save) 后，将出现一个新的“租赁车辆” (Rental Car) 选项卡。

1. Vehicle Entry | 2. Repair | 3. Close

Vehicle Entry

WW0221: Mileage > Km 150000
WW0261: This car covers on average over 100 km per day

Service Entry #	Opening date	Last Update	Days down	Vehicle Downtime	Previous Repair#
IT0098594	06.10.2023	27.11.2023 - WBTESTHQ2	53	2	4

Service Entry Status: - Open | Status Changes: Repair in Progress

Dealer: 052222 - ROSSOCORSA S.R.L.

Chassis no.: 392207 | Plate #: mddd44 | Customer Name: LEVANTE HYBRID | Actual Owner: Yes No N/A

Repair Order#: 89581 | Repair order opening date: 06.10.2023 | Mileage In: 150000 Km | M | Vehicle towed in due to technical issues: Yes No | Loaner Car: Yes No | Open Customer Case: Yes No | Rental Car: Yes No

Mobility services provided: Yes No

Service Note: [Empty]

1 selected

- Maserati Loaner Car
- Another brand loaner car
- Rental Car
- Public Transportation
- Pick up & delivery
- Maserati Connect active subscription for the registration process.

Warning: WW0656: The VIN has been previously repaired on... WW0370: No Open Campaigns for this vehicle. There is no Maserati Connect active subscription for...

Vehicle Information | Campaign | Warranty | BOL | Vehicle Configuration Update | Service Entry | Rental Car | Maserati Connect | Maintenance

Vehicle Information		Finish	
Chassis no.	392207	External Color	94084201 BIANCO
Vehicle	861170000	Internal Color	94084354 BLACK/RED
VIN	7N6A1161R00Y302207	Cam...	94084345 BLACK/BLACK/DEF



租赁车辆的相关功能仅适用于特定市场！

更换车辆管理

租赁车辆：标准天数分配

在“租赁车辆” (Rental Car) 选项卡中，您可以：

1. 单击“添加” (Add) 按钮，分配租赁车辆。
2. 插入租车额外天数请求。

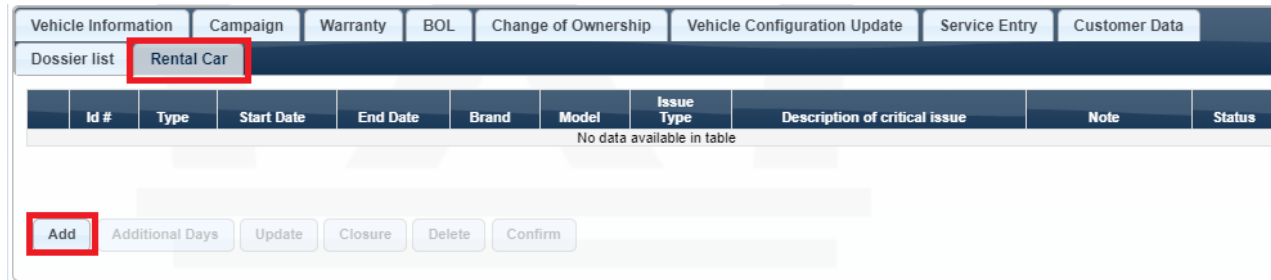

The screenshot shows a web application interface for managing rental cars. At the top, there are several tabs: Vehicle Information, Campaign, Warranty, BOL, Change of Ownership, Vehicle Configuration Update, Service Entry, and Customer Data. Below these is a 'Dossier list' with a sub-tab for 'Rental Car'. A table with columns 'Id #', 'Type', 'Start Date', 'End Date', 'Brand', 'Model', 'Issue Type', 'Description of critical issue', 'Note', and 'Status' is displayed, with a message 'No data available in table' below it. At the bottom, there is a row of buttons: 'Add', 'Additional Days', 'Update', 'Closure', 'Delete', and 'Confirm'. The 'Add' button is highlighted with a red box.

单击“添加” (Add) 按钮，系统将显示一个弹出窗口，您必须在其中插入分配的“开始日期” (Start Date) 和“结束日期” (End Date)，以及车辆品牌和型号。

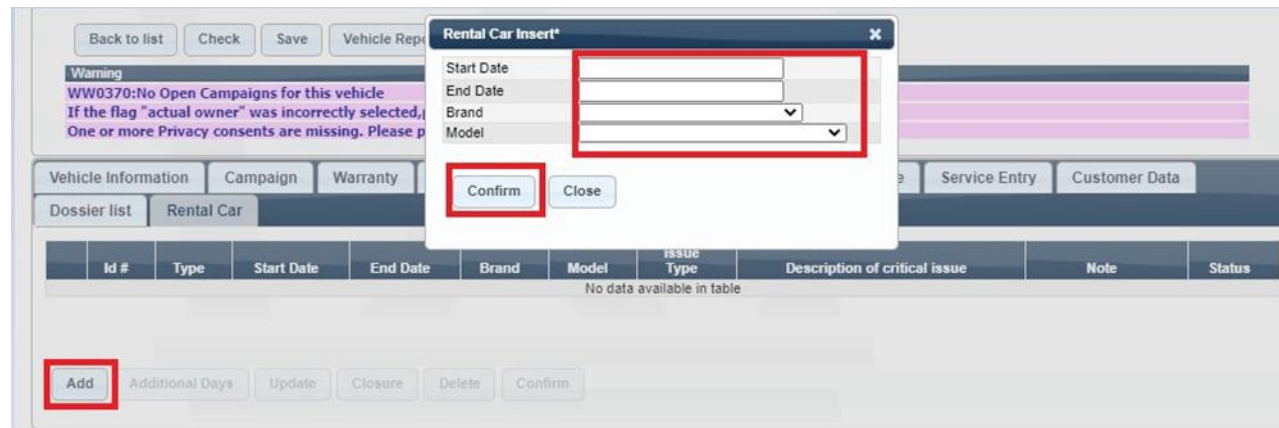

The screenshot shows the same interface as above, but with a 'Rental Car Insert*' dialog box open. The dialog box has fields for 'Start Date', 'End Date', 'Brand', and 'Model'. The 'Start Date' and 'End Date' fields are highlighted with a red box. Below the fields are 'Confirm' and 'Close' buttons, with 'Confirm' also highlighted with a red box. In the background, the 'Add' button from the previous screenshot is also highlighted with a red box.

更换车辆管理

租赁车辆：额外天数请求

- 插入开始日期后，单击“确认”(Confirm)按钮，将自动填入比开始日期早 5 天的结束日期，否则可以手动插入，系统将检查日期的一致性并保存记录。
- 车辆品牌和型号不是必填项，但建议插入以供记录。
- 标准分配最多 5 天，但维修时间可能更长。在这种情况下，您可以按照下一段中显示的流程提交额外天数请求，为车辆分配更多天数。
- 单击复选框可以修改或删除记录中的信息。如果记录已删除，则在输入额外天数请求之前，必须输入其他标准天数请求。



如果代步车已分配，并且在租赁车辆开始日期分配时分配尚未关闭，则租赁车辆分配将被阻止。

如果租赁车辆已在过去完成分配，当前并非连续操作，则租赁车辆分配将被阻止。

Vehicle Information		Campaign	Warranty	BOL	Change of Ownership	Vehicle Configuration Update	Service Entry	Customer Data		
Dossier list		Rental Car								
	Id #	Type	Start Date	End Date	Brand	Model	Issue Type	Description of critical issue	Note	Status
<input type="checkbox"/>	1	S	08.02.2021	12.02.2021	JEEP	RENEGADE				01 - Standard

更换车辆管理

租赁车辆：额外天数请求

插入标准天数记录后，“额外天数” (Additional Days) 按钮将启用，单击后将出现一个弹出窗口。

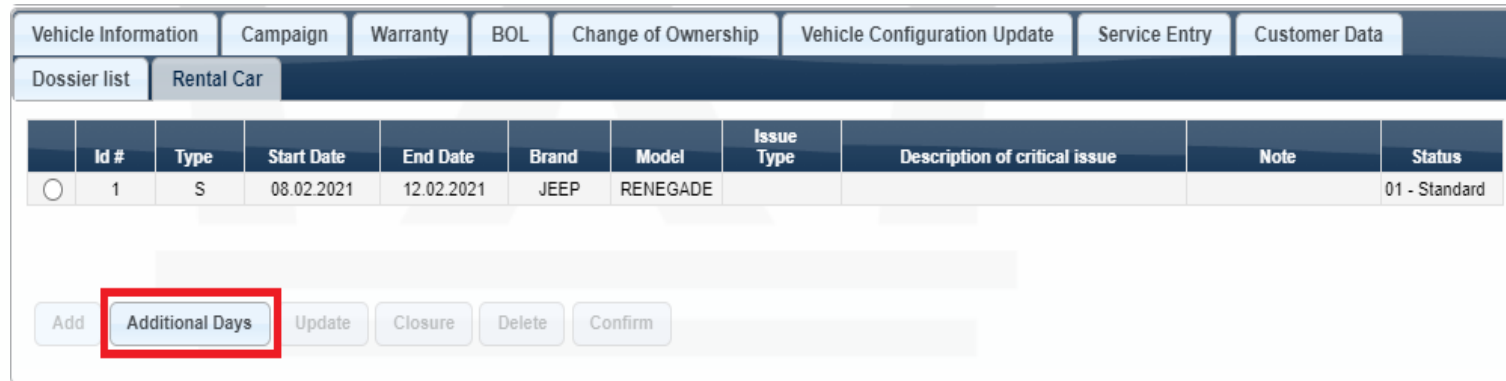

The screenshot displays a software interface for vehicle management. At the top, there are several tabs: Vehicle Information, Campaign, Warranty, BOL, Change of Ownership, Vehicle Configuration Update, Service Entry, and Customer Data. Below these, there are two sub-tabs: Dossier list and Rental Car. The main area contains a table with the following data:

	Id #	Type	Start Date	End Date	Brand	Model	Issue Type	Description of critical issue	Note	Status
<input type="radio"/>	1	S	08.02.2021	12.02.2021	JEEP	RENEGADE				01 - Standard

Below the table, there is a row of buttons: Add, Additional Days, Update, Closure, Delete, and Confirm. The 'Additional Days' button is highlighted with a red rectangular box.

更换车辆管理

租赁车辆：额外天数请求

系统会自动将开始日期设置为“租赁车辆”标准请求结束日期的次日。品牌和型号不是必填项，但建议插入以供参考。

必须通过下拉菜单选择原因（BOL、备件订单或其他）。

如果原因是“BOL”，还需要插入 BOL 编号参考。

如果原因是“备件订单” (Spare Part Order)，还需要插入备件订单号、ETA 和零件编号。

如果原因是“其他” (Other)，还需要填写“注释”字段。

必须手动输入额外天数请求的结束日期。

单击“确认” (Confirm) 按钮后，将创建一个状态为“草稿” (Draft) 的请求。

The screenshot displays the 'Extra Days*' modal forms in a web application. The background shows a vehicle information table with columns: Id #, Type, Start Date, End Date, Brand, and Model. The table contains one row with Id # 1, Type S, Start Date 08.02.2021, End Date 12.02.2021, Brand JEEP, and Model RENE. Below the table are buttons: Add, Additional Days (highlighted in red), Update, Closure, Delete, and Confirm.

Three 'Extra Days*' modal forms are overlaid on the screen, each with a 'Confirm' button highlighted in red:

- Form 1 (BOL):** Start Date: 13.02.2021, End Date: (empty), Brand: (empty), Model: (empty), Issue Type: BOL, BOL# Reference: (empty), Note: (empty).
- Form 2 (Spare Parts Order):** Start Date: 13.02.2021, End Date: (empty), Brand: (empty), Model: (empty), Issue Type: Spare Parts Order, Order: (empty), ETA*: (empty), Part Code: (empty), Note: (empty).
- Form 3 (Other):** Start Date: 13.02.2021, End Date: (empty), Brand: (empty), Model: (empty), Issue Type: Other, Note: (empty).

Additional details visible in the background include: Dealer: 080839 - HR OWEN SP, Chassis no.: 302268, Repair Order#: 47596, Service Note: NP 21/12/2020 Apple, Actual Owner: Yes (radio), No (radio), Rental Car: Yes (radio), No (radio).

更换车辆管理

租赁车辆：额外天数请求

通过勾选复选框选择作业线，您现在有 3 个选项：

- “更新” (Update) 按钮，在需要修改信息时使用；
- “删除” (Delete) 按钮，在请求完全错误时使用；
- “确认” (Confirm) 按钮，用于将请求发送到客户服务中心。

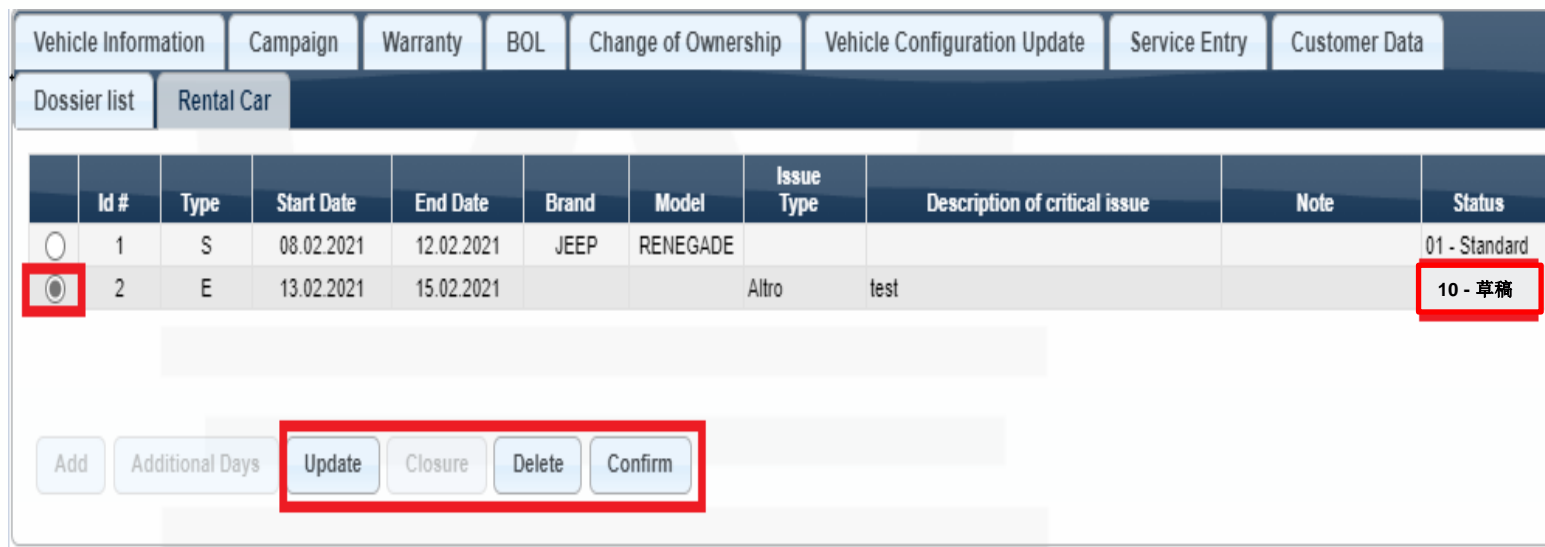

The screenshot displays a software interface for managing rental vehicles. At the top, there are several tabs: Vehicle Information, Campaign, Warranty, BOL, Change of Ownership, Vehicle Configuration Update, Service Entry, and Customer Data. Below these is a sub-header with 'Dossier list' and 'Rental Car'. The main part of the interface is a table with the following columns: Id #, Type, Start Date, End Date, Brand, Model, Issue Type, Description of critical issue, Note, and Status. Two rows are visible: Row 1 has Id # 1, Type S, Start Date 08.02.2021, End Date 12.02.2021, Brand JEEP, Model RENEGADE, and Status 01 - Standard. Row 2 has Id # 2, Type E, Start Date 13.02.2021, End Date 15.02.2021, Brand (blank), Model Altro, Issue Type test, and Status 10 - 草稿. Below the table is a row of buttons: Add, Additional Days, Update, Closure, Delete, and Confirm. The 'Update' button is highlighted with a red box. In the original image, the radio button for row 2 and the '10 - 草稿' status are also highlighted with red boxes.

	Id #	Type	Start Date	End Date	Brand	Model	Issue Type	Description of critical issue	Note	Status
<input type="radio"/>	1	S	08.02.2021	12.02.2021	JEEP	RENEGADE				01 - Standard
<input checked="" type="radio"/>	2	E	13.02.2021	15.02.2021		Altro	test			10 - 草稿

Buttons: Add, Additional Days, Update, Closure, Delete, Confirm

更换车辆管理

租赁车辆：更新分配

要编辑标准和额外天数分配，需要勾选相关作业线的复选框，然后单击“更新” (Update) 按钮。在创建新的额外天数请求之前，标准分配的所有部分均可编辑。

处于“草稿”状态下的额外天数的所有部分均可编辑，但开始日期（由系统提供）除外。

请求得到确认（发送到客户服务中心）后，无法再修改，唯一可用选项为“删除”。

The screenshot displays the Rental Car management interface. It features a table with columns: Id #, Type, Start Date, End Date, Brand, Model, Issue Type, Description of critical issue, Note, and Status. Two 'Rental Car Edit' dialog boxes are open, showing fields for Start Date, End Date, Brand, and Model. The 'Update' button is highlighted in red in the bottom left. The 'Confirm' button is highlighted in red in the bottom right. The status '10 - 草稿' is highlighted in red in the bottom right. A warning message is visible at the top: 'Warning WW0370: No Open Campaigns for this vehicle. If the flag "actual owner" was incorrectly selected, One or more Privacy consents are missing. Please p...'

Id #	Type	Start Date	End Date	Brand	Model	Issue Type	Description of critical issue	Note	Status
1	S	08.02.2021	12.02.2021	JEEP	RENEGADE				01 - Standard
2	E	13.02.2021	15.02.2021	JEEP	RENEGADE	Altro	test		10 - 草稿

更换车辆管理

租赁车辆：删除分配

如果需要删除标准或额外天数分配，则需要勾选相关作业线的复选框，然后单击“删除”(Delete) 按钮。

对于“标准”分配，该选项仅在插入“额外天数”请求之前可用。

对于“额外天数”请求，该选项适用于处于“草稿”或“新”状态下的请求。

The screenshot displays a software interface for vehicle management. It features a table with columns: Id #, Type, Start Date, End Date, Brand, Model, Issue Type, Description of critical issue, Note, and Status. Two dialog boxes, 'Delete row #1*' and 'Delete row #2*', are overlaid on the interface, each with a 'Confirm' button highlighted by a red box. The 'Delete row #2*' dialog is positioned over a row in the table with Id # 2, Type E, Start Date 13.02.2021, End Date 15.02.2021, Brand JEEP, Model RENEGADE, Issue Type Altro, and Status 10 - 草稿. The 'Delete' button in the interface is also highlighted with a red box. A warning message is visible at the top: 'Warning WW0370: No Open Campaigns for this vehicle. If the flag "actual owner" was incorrectly selected, One or more Privacy consents are missing. Please p...'. The interface includes tabs for 'Vehicle Information', 'Campaign', 'Warranty', 'Service Entry', and 'Customer Data', and buttons for 'Add', 'Additional Days', 'Update', 'Close', and 'Delete'.

Id #	Type	Start Date	End Date	Brand	Model	Issue Type	Description of critical issue	Note	Status
1	S	08.02.2021	12.02.2021	JEEP	RENEGADE				01 - Standard
2	E	13.02.2021	15.02.2021	JEEP	RENEGADE	Altro	test		10 - 草稿

更换车辆管理

租赁车辆：确认分配

“确认”按钮仅适用于“额外天数”请求。事实上，标准分配在插入时即被视为已确认。插入“额外天数”请求后，其状态为“草稿”，需要确认才能发送到客户服务中心进行评估。

您必须确保信息正确无误，勾选相关作业线复选框，然后单击“确认”(Confirm)按钮。此时会出现一个弹出窗口，必须再次选择“确认”(Confirm)按钮。

Id #	Type	Start Date	End Date	Brand	Note	Status
1	S	08.02.2021	12.02.2021	JEEP		01 - Standard
2	E	13.02.2021	15.02.2021	Altro	test	10 - 草稿

此时，请求状态会变为“新”，客户服务中心 (CSC) 会收到一封电子邮件，告知请求已提交。

Id #	Type	Start Date	End Date	Brand	Model	Issue Type	Description of critical issue	Note	Status
1	S	08.02.2021	12.02.2021	JEEP	RENEGADE				01 - Standard
2	E	13.02.2021	15.02.2021	Altro		test			15 - 新

更换车辆管理

租赁车辆：确认分配

发送到 CSC 的请求只能在 CSC 进行评估之前删除。之后，状态将变为“等待授权”(Waiting for Authorization)，所有按钮将被禁用。

Vehicle Information Campaign Warranty BOL Vehicle Configuration Update Service Entry Customer Data Rental Car										
	Id #	Type	Start Date	End Date	Brand	Model	Issue Type	Description of critical issue	Note	Status
<input type="radio"/>	1	S	08.02.2021	12.02.2021	JEEP	RENEGADE				01 - Standard
<input checked="" type="radio"/>	2	E	13.02.2021	15.02.2021			Altro	test		20 - 等待授权

Add Additional Days Update Closure Delete Confirm

CSC 可以决定拒绝或确认请求。确认请求后，您可以通过“关闭”(Close) 按钮手动关闭请求，还是通过“额外天数”(Additional Days) 按钮添加其他额外天数请求。

Vehicle Information Campaign Warranty BOL Vehicle Configuration Update Service Entry Customer Data Rental Car										
	Id #	Type	Start Date	End Date	Brand	Model	Issue Type	Description of critical issue	Note	Status
<input type="radio"/>	1	S	08.02.2021	12.02.2021	JEEP	RENEGADE				01 - Standard
<input checked="" type="radio"/>	2	E	13.02.2021	15.02.2021			Altro	test		25 已确认

Add Additional Days Update Closure Delete Confirm

更换车辆管理

租赁车辆：确认分配

如果请求被拒绝，您可以在“说明”(Note) 字段中查看拒绝原因，并通过“额外天数”(Additional Days) 按钮插入新请求。

Vehicle Information											Campaign	Warranty	BOL	Vehicle Configuration Update	Service Entry	Customer Data	Rental Car
	Id #	Type	Start Date	End Date	Brand	Model	Issue Type	Description of critical issue	Note	Status							
<input type="radio"/>	1	S	08.02.2021	12.02.2021	JEEP	RENEGADE				01 - Standard							
<input type="radio"/>	2	E	13.02.2021	15.02.2021			Altro	test		25 - Confermata							
<input type="radio"/>	3	E	16.02.2021	19.02.2021			BOL 000000001981534		missing information	30 - 已拒绝							

更换车辆管理

租赁车辆：关闭分配

关闭保养条目后，分配会在结束日期自动关闭，也可在请求结束日期之前手动关闭。手动关闭只适用于“已确认”请求，方法是勾选作业线复选框并单击“关闭”(Close)按钮。单击“关闭”后，状态将变为“已手动关闭”(Manually Closed)。

Vehicle Information		Campaign	Warranty	BOL	Vehicle Configuration Update		Service Entry	Customer Data	Rental Car	
	Id #	Type	Start Date	End Date	Brand	Model	Issue Type	Description of critical issue	Note	Status
<input type="radio"/>	1	S	08.02.2021	12.02.2021	JEEP	RENEGADE				01 - Standard
<input type="radio"/>	2	E	13.02.2021	15.02.2021			Altro	test		25 - Confermata
<input type="radio"/>	3	E	16.02.2021	19.02.2021			BOL 000000001981534		missing information	30 - Rifiutata
<input checked="" type="radio"/>	4	E	04.02.2021	19.02.2021			Ordine Ricambi 47521	VOR Eta 19.02.2021 Code 46328330		45 - 手动关闭

Buttons: Add, Additional Days, Update, Closure, Delete, Confirm



在请求处于“新”或“等待授权”状态之前，无法关闭保养条目。
保养条目关闭后，您无法更新请求。

如果分配（标准或额外天数）已过期，系统会发出警告信息。每次输入保养条目时，消息都会更新。
如果您更新请求，则消息在您退出并再次输入保养条目之前不会消失。

Vehicle Information	Campaign	Warranty	BOL	Vehicle Configuration Update	Service Entry	Customer Data	Dossier list	Rental Car
Warning WW0370:No Open Campaigns for this vehicle If the flag "actual owner" was incorrectly selected,please contact ABH/RAM WW2045:Rental car assignment expired. One or more Privacy consents are missing. Please present our Policy to the customer and request consents.								



最佳实践

最佳实践

指南

保养条目+ 是 Maserati 监控车辆在车间的保养进度的方法。

请按照以下指示，以最佳方式管理保养条目：

- 车辆进入车间后，必须无条件打开“保养条目”，其中必须包含与执行的车辆保养和维修干预相关的所有信息。
- 强烈建议同时打开保养条目和维修单：打开二者的平均间隔时间应少于 1 天。
- 同样，在将车辆返回给客户之后，必须在关闭维修单后立即关闭保养条目。在这种情况下，关闭二者的平均间隔时间也应少于 1 天。
- 在保养条目关闭阶段，必须注意输入数据的正确性，特别是用于计算“总故障天数”（维修单打开日期与最后一次打卡日期的间隔天数）的“最后一次打卡日期”，更要确保其准确无误。
- 此外，在适当时间关闭保养条目，还能避免在向客户发送 Maserati CSI 调查表时造成不便。

最佳实践

重要提示

- 保养条目不得处于等待完成保修索赔的打开状态；不需打开 BOL 请求的保养条目在关闭之后，即可创建、完成和提交保修索赔。
- 如果车辆因故离开车间（即，无零件可用或客户需要使用车辆等），则必须关闭相应保养条目，并在车辆返回后打开一个新的保养条目以完成维修。

